

WOOFER GDN 25/80/1 / 3

9 5151 119

TECHNICAL DATA

Rated impedance	8	Ω
Voice coil resistance	6,4	Ω
Rated frequency range	60 to 3000	Hz
Resonance frequency	37	Hz
Power handling capacity / enclosure 35 dm ³ , 100 h continuous /	80	W
Max power	130	W
Sensitivity	89	dB
Flux density	0,76	T
Energy in air gap	510	mJ
Force factor - BI	9,8	Tm
Piston area - S _D	0,033	m ²
Total moving mass - M _{MS}	0,026	kg
Compliance /loudspeaker unmounted/ - C _{MS}	71,3 x 10 ⁻⁴	m/N
Equivalent box volume - V _{AS}	0,113	m ³
Quality factor /loudspeaker unmounted/		
- mechanical - Q _{MS}	2,6	
- electrical - Q _{ES}	0,49	
- total - Q _{TS}	0,41	
Air - gap	48/11,2/1,775	mm
Voice coil height	18,5	mm
Magnet		
- material	ferrite	
- dimensions	120/60/18	mm
- mass	0,76	kg
Mass of loudspeaker	2,8	kg

AVAILABLE VERSIONS

- GDN 25/80/1 - 8Ω, catalogue number 9 5151 119 02
- GDN 25/80/3 - 8Ω, catalogue number 9 5151 119 04, metalized dust cap

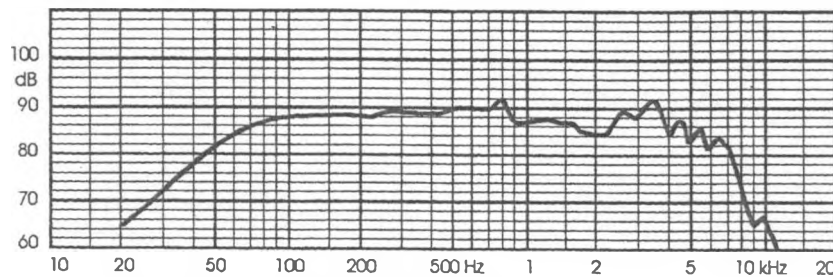
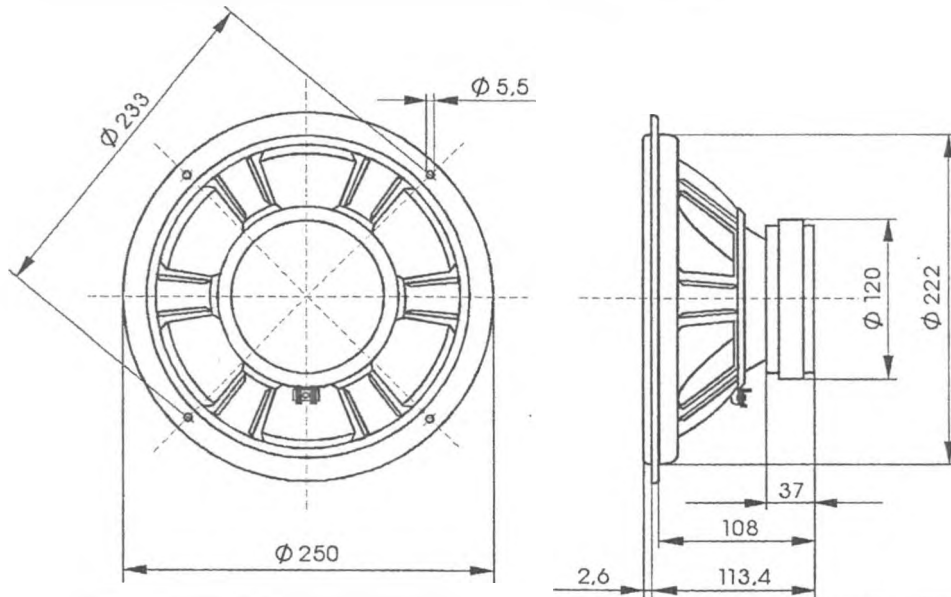

FREQUENCY RESPONSE CURVE

Measured in anechoic room at 1W/ 1m, Loudspeaker mounted in sealed 35 dm³ enclosure.