

MKH 20 P 48

Microphones | RF Symmetrical Capsule Condenser Microphone

Cat. No. 002857

General Description

The omni-directional MKH 20 is usually used as a main microphone for orchestras and solo instruments, and picks up the natural acoustics of the room, though it does have a much wider range of applications as omni-directional microphones do not suffer from 'proximity effect'.



Cable pictured is an accessory not supplied with the microphone

Features

- Exceptionally flat frequency response, switchable for near and diffuse field applications
- High-frequency response can be accentuated by means of a pressure build-up ring
- Slightly increasing directivity at high frequencies to adjust tonal balance
- Exceptionally low inherent self-noise
- Transformerless and fully floating balanced output
- Switchable pre-attenuation
- Black, anodised light metal body
- Delivery includes: 1 MKH 20, 1 MZS 40 shock mount, 1 MZW 41 windshield, 1 pressure build-up ring

Recommended Accessories

- | | |
|---|-----------------|
| ■ MZA 14 P 48 U battery power supply unit | Cat. No. 002960 |
| ■ MZT 441 table stand | Cat. No. 000799 |
| ■ MZT 100 table stand | Cat. No. 001883 |
| ■ MZD 30 dual clip, for MS stereo | Cat. No. 002990 |
| ■ MZB 415 fish pole | Cat. No. 000972 |
| ■ MZS 40 shock mount | Cat. No. 003017 |
| ■ MZW 41 foam windshield | Cat. No. 029681 |
| ■ MZP 40 popshield | Cat. No. 003132 |
| ■ MZS 20-1 shock mount | Cat. No. 003609 |
| ■ MZW 20-1 basket windshield | Cat. No. 003606 |
| ■ MZH 20-1 hairy cover | Cat. No. 003610 |

Technical Data

Pick-up pattern	omni-directional
Frequency response	12 – 20,000 Hz
Sensitivity (free field, no load, 1 kHz)	25 (8) mV/Pa ± 1 dB
Nominal impedance	150 Ω
Min. terminating impedance	1 kΩ
Equivalent noise level	
A-weighted (DIN IEC 651)	10 (18) dB
CCIR-weighted (CCIR 468-3)	20 (28) dB
Max. sound pressure level	134 (142) dB at 1 kHz
Power supply	phantom 48 ± 4 V
Supply current	2 mA
Dimensions	∅ 25 x 153 mm
Weight	approx. 100 g

Values in parentheses with attenuator switched on (-10 dB)

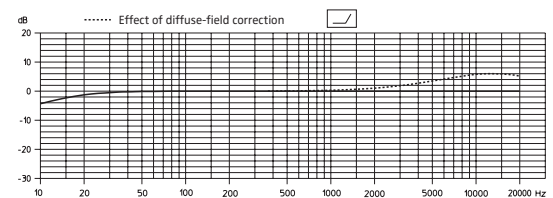
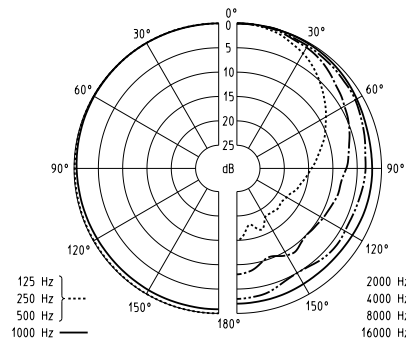

Profile

Omni-directional studio microphone with switchable diffuse-field correction, switchable pre-attenuation and pressure build-up ring, frequency response 12 Hz – 20,000 Hz, sensitivity (free field, no load) 25 (8) mV/Pa ± 1 dB at 1 kHz, nominal impedance 150 Ω, min. terminating impedance 1 kΩ, equivalent noise level A-weighted 10 (18) dB, CCIR-weighted 20 (28) dB, max. SPL 134 (142) dB at 1 kHz, phantom powering 48 ± 4 V, supply current 2 mA, dimensions in mm ∅ 25 x 153, weight approx. 100 g. Values in parentheses with attenuator switched on (-10 dB).