



## Wideband Dual-Channel Linear Multiplier/Divider

# AD539

### FEATURES

- Two Quadrant Multiplication/Division
- Two Independent Signal Channels
- Signal Bandwidth of 60MHz ( $I_{OUT}$ )
- Linear Control Channel Bandwidth of 5MHz
- Low Distortion (to 0.01%)
- Fully-Calibrated, Monolithic Circuit

### APPLICATIONS

- Precise High Bandwidth AGC and VCA Systems
- Voltage-Controlled Filters
- Video-Signal Processing
- High-Speed Analog Division
- Automatic Signal-Leveling
- Square-Law Gain/Loss Control

### PRODUCT DESCRIPTION

The AD539 is a low-distortion analog multiplier having two identical signal channels (Y1 and Y2), with a common X-input providing linear control of gain. Excellent ac characteristics up to video frequencies and a 3dB bandwidth of over 60MHz are provided. Although intended primarily for applications where speed is important the circuit exhibits good static accuracy in "computational" applications. Scaling is accurately determined by a band-gap voltage reference and all critical parameters are laser-trimmed during manufacture.

The full bandwidth can be realized over most of the gain range using the AD539 with simple resistive loads of up to 100 $\Omega$ . Output voltage is restricted to a few hundred millivolts under these conditions. Using external op amps such as the AD5539 in conjunction with the on-chip scaling resistors, accurate multiplication can be achieved, with bandwidths typically as high as 50MHz.

The two channels provide flexibility. In single-channel applications they may be used in parallel, to double the output current, or in series, to achieve a square-law gain function with a control range of over 100dB, or differentially, to reduce distortion. Alternatively, they may be used independently, as in audio stereo applications, with low crosstalk between channels. Voltage-controlled filters and oscillators using the "state-variable" approach are easily designed, taking advantage of the dual channels and common control. The AD539 can also be configured as a divider with signal bandwidths up to 15MHz.

Power consumption is only 135mW using the recommended  $\pm 5V$  supplies. The AD539 is available in three versions: the "J" and "K" grades are specified for 0 to +70°C operation and "S" grade is guaranteed over the extended range of -55°C to +125°C. The J and K grades are available in either a hermetic ceramic DIP (D) or a low cost plastic DIP (N), while the S

REV. A

Information furnished by Analog Devices is believed to be accurate and reliable. However, no responsibility is assumed by Analog Devices for its use, nor for any infringements of patents or other rights of third parties which may result from its use. No license is granted by implication or otherwise under any patent or patent rights of Analog Devices.

### PIN CONFIGURATION

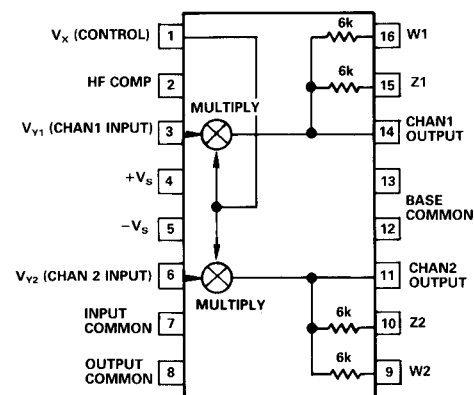

grade is available in ceramic DIP (D) or LCC (E). J-grade chips are also available. The S grade is now available in MIL-STD-883 and Standard Military Drawing (DESC) Number 5962-8980901EA versions.

### DUAL SIGNAL CHANNELS

The signal voltage inputs,  $V_{Y1}$  and  $V_{Y2}$ , have nominal full-scale (FS) values of  $\pm 2V$  with a peak range to  $\pm 4.2V$  (using a negative supply of 7.5V or greater). For video applications where differential phase is critical a reduced input range of  $\pm 1$  volt is recommended, resulting in a phase variation of typically  $\pm 0.2^\circ$  at 3.579MHz for full gain. The input impedance is typically 400k $\Omega$  shunted by 3pF. Signal channel distortion is typically well under 0.1% at 10kHz and can be reduced to 0.01% by using the channels differentially.

### COMMON CONTROL CHANNEL

The control channel accepts positive inputs,  $V_X$ , from 0 to +3V FS,  $\pm 3.3V$  peak. The input resistance is 500 $\Omega$ . An external, grounded capacitor determines the small-signal bandwidth and recovery time of the control amplifier; the minimum value of 3nF allows a bandwidth at mid-gain of about 5MHz. Larger compensation capacitors slow the control channel but improve the high-frequency performance of the signal channels.

### FLEXIBLE SCALING

Using either one or two external op amps in conjunction with the on-chip 6k $\Omega$  scaling resistors, the output currents (nominally  $\pm 1mA$  FS,  $\pm 2.25mA$  peak) can be converted to voltages with accurate transfer functions of  $V_W = -V_X V_Y / 2$ ,  $V_W = -V_X V_Y$  or  $V_W = -2V_X V_Y$  (where inputs  $V_X$  and  $V_Y$  and output  $V_W$  are expressed in volts), with corresponding full-scale outputs of  $\pm 3V$ ,  $\pm 6V$  and  $\pm 12V$ . Alternatively, low-impedance grounded loads can be used to achieve the full signal bandwidth of 60MHz, in which mode the scaling is less accurate.

One Technology Way, P.O. Box 9106, Norwood, MA 02062-9106, U.S.A.  
Tel: 617/329-4700 Fax: 617/326-8703 Twx: 710/394-6577  
Telex: 924491 Cable: ANALOG NORWOODMASS

# AD539 — SPECIFICATIONS (@ T<sub>A</sub> = 25°C, V<sub>S</sub> = ±5V, unless otherwise specified)

Parameter	Conditions	AD539J			AD539K			AD539S			Units
		Min	Typ	Max	Min	Typ	Max	Min	Typ	Max	
<b>SIGNAL-CHANNEL DYNAMICS</b>											
Minimal Configuration	Reference Figure 6a										
Bandwidth, -3dB	R <sub>L</sub> = 50Ω, C <sub>C</sub> = 0.01μF	30	60		30	60		30	60		MHz
Maximum Output	+0.1V < V <sub>X</sub> < +3V, V <sub>Yac</sub> = 1V rms		-10			-10			-10		dBm
Feedthrough, f < 1MHz	V <sub>X</sub> = 0, V <sub>Yac</sub> = 1.5V rms		-75			-75			-75		dBm
	f = 20MHz		-55			-55			-55		dBm
Differential Phase Linearity											Degrees
-1V < V <sub>Ydc</sub> < +1V	f = 3.58MHz, V <sub>X</sub> = +3V,		±0.2			±0.2			±0.2		Degrees
-2V < V <sub>Ydc</sub> < +2V	V <sub>Yac</sub> = 100mV		±0.5			±0.5			±0.5		Degrees
Group Delay	V <sub>X</sub> = +3V, V <sub>Yac</sub> = 1V rms, f = 1MHz		4			4			4		ns
<b>Standard Dual-Channel Multiplier</b>											
Maximum Output	Reference Figure 2		4.5			4.5			4.5		V
Feedthrough, f < 100kHz	V <sub>X</sub> = +3V, V <sub>Yac</sub> = 1.5V rms		1			1			1		mV rms
Crosstalk (CH1 to CH2)	V <sub>X</sub> = 0, V <sub>Yac</sub> = 1V rms										dB
	V <sub>Y1</sub> = 1V rms, V <sub>Y2</sub> = 0										nV/√Hz
	V <sub>X</sub> = +3V, f < 100kHz		-40			-40			-40		%
RTO Noise, 10Hz to 1MHz	V <sub>X</sub> = +1.5V, V <sub>Y</sub> = 0, Figure 2		200			200			200		%
THD + Noise, V <sub>X</sub> = +1V,	f = 10kHz, V <sub>Yac</sub> = 1V rms		0.02			0.02			0.02		%
V <sub>Y</sub> = +3V	f = 10kHz, V <sub>Yac</sub> = 1V rms		0.04			0.04			0.04		%
<b>Wide Band Two-Channel Multiplier</b>											
Bandwidth, -3dB (LH0032)	Figure 2		25			25			25		MHz
Maximum Output V <sub>X</sub> = +3V	+0.1V < V <sub>X</sub> < +3V, V <sub>Yac</sub> = 1V rms		4.5			4.5			4.5		V rms
Feedthrough V <sub>X</sub> = 0V	V <sub>Yac</sub> = 1.5V rms, f = 3MHz		14			14			14		mV rms
<b>Wide Band Single Channel VCA (AD5539)</b>											
Bandwidth, -3dB	Reference Figure 8		50			50			50		MHz
Maximum Output	+0.1V < V <sub>X</sub> < +3V, V <sub>Yac</sub> = 1V rms		±1			±1			±1		V
Feedthrough	75Ω Load		-54			-54			-54		dB
	V <sub>X</sub> = -0.01V, f = 5MHz										
<b>CONTROL CHANNEL DYNAMICS</b>											
Bandwidth, -3dB	C <sub>C</sub> = 3000pF, V <sub>Xdc</sub> = +1.5V, V <sub>Yac</sub> = 100mV rms		5			5			5		MHz
<b>SIGNAL INPUTS, V<sub>Y1</sub> &amp; V<sub>Y2</sub></b>											
Nominal Full-Scale Input			±2			±2			±2		V
Operational Range, Degraded Performance	-V <sub>S</sub> ≤ 7V	±4.2			±4.2			±4.2			V
Input Resistance			400			400			400		kΩ
Bias Current			10	30		10	20		10	30	μA
Offset Voltage	V <sub>X</sub> = +3V, V <sub>Y</sub> = 0		5	20		5	10		5	20	mV
(T <sub>min</sub> to T <sub>max</sub> )			10			5			15	35	mV
Power Supply Sensitivity	V <sub>X</sub> = +3V, V <sub>Y</sub> = 0		2			2			2		mV/V
<b>CONTROL INPUT, V<sub>X</sub></b>											
Nominal Full-Scale Input			+3.0			+3.0			+3.0		V
Operational Range, Degraded Performance		+3.2			+3.2			+3.2			V
Input Resistance <sup>1</sup>			500			500			500		Ω
Offset Voltage			1	4		1	2		1	4	mV
(T <sub>min</sub> to T <sub>max</sub> )			3			2			2	5	mV
Power Supply Sensitivity			30			30			30		μV/V
Gain	(Figure 2)										
Absolute Gain Error	V <sub>X</sub> = +0.1V to +3.0V and V <sub>Y</sub> = ±2V		0.2	0.4		0.1	0.2		0.2	0.4	dB
(T <sub>min</sub> to T <sub>max</sub> )			0.3			0.15			0.25	0.5	dB
<b>CURRENT OUTPUT<sup>1</sup></b>											
Full-Scale Output Current	V <sub>X</sub> = +3V, V <sub>Y</sub> = ±2V		±1			±1			±1		mA
Peak Output Current	V <sub>X</sub> = +3.3V, V <sub>Y</sub> = ±5V, V <sub>S</sub> = ±7.5V	±2	±2.8		±2	±2.8		±2	±2.8		mA
Output Offset Current	V <sub>X</sub> = 0, V <sub>Y</sub> = 0		0.2	1.5		0.2	1.5		0.2	1.5	μA
Output Offset Voltage <sup>2</sup>	Figure 2, V <sub>X</sub> = 0, V <sub>Y</sub> = 0		3	10		3	10		3	10	mV
Output Resistance <sup>1</sup>			1.2			1.2			1.2		kΩ
Scaling Resistors											
CH1	Z1, W1 to CH1		6			6			6		kΩ
CH2	Z2, W2 to CH2		6			6			6		kΩ
<b>VOLTAGE OUTPUTS, V<sub>W1</sub> &amp; V<sub>W2</sub><sup>2</sup></b>											
Multiplier Transfer Function, Either Channel	(Figure 2)										
Multiplier Scaling Voltage, V <sub>U</sub>			V <sub>W</sub> = -V <sub>X</sub> ·V <sub>Y</sub> /V <sub>U</sub>			V <sub>W</sub> = -V <sub>X</sub> ·V <sub>Y</sub> /V <sub>U</sub>			V <sub>W</sub> = -V <sub>X</sub> ·V <sub>Y</sub> /V <sub>U</sub>		V
Accuracy		0.98	1.0	1.02	0.99	1.0	1.01	0.98	1.0	1.02	%
(T <sub>min</sub> to T <sub>max</sub> )			0.5	2		0.5	1		0.5	2	%
Power Supply Sensitivity			1			0.5			1.0	3	%
Total Multiplication Error <sup>3</sup>			0.04			0.04			0.04		%/V
T <sub>min</sub> to T <sub>max</sub>	V <sub>X</sub> < +3V, -2V < V <sub>Y</sub> < 2V		1	2.5		0.6	1.5		1	2.5	%FSR
Control Feedthrough			2			1			2	4	%
(T <sub>min</sub> to T <sub>max</sub> )	V <sub>X</sub> = 0 to +3V, V <sub>Y</sub> = 0		25	60		15	30		15	60	mV
			30			15			60	120	mV
<b>TEMPERATURE RANGE</b>											
Rated Performance		0		+70	0		+70	-55		+125	°C
<b>POWER SUPPLIES</b>											
Operational Range		±4.5		±15	±4.5		±15	±4.5		±15	V
Current Consumption			8.5	10.2		8.5	10.2		8.5	10.2	mA
+V <sub>S</sub>			18.5	22.2		18.5	22.2		18.5	22.2	mA
-V <sub>S</sub>											

## NOTES

<sup>1</sup>Resistance value and absolute current outputs subject to 20% tolerance.

<sup>2</sup>Spec assumes the external op amp is trimmed for negligible input offset.

<sup>3</sup>Includes all errors.

Specifications subject to change without notice.

Specifications shown in boldface are tested on all production units at final electrical test. Results from those tests are used to calculate outgoing quality levels. All min and max specifications are guaranteed, although only those shown in boldface are tested on all production units.

## ORDERING GUIDE

Model	Temperature Range	Package Description	Package Option
AD539JN	0°C to +70°C	Plastic DIP	N-16
AD539KN	0°C to +70°C	Plastic DIP	N-16
AD539JD	0°C to +70°C	Side Brazed DIP	D-16
AD539KD	0°C to +70°C	Side Brazed DIP	D-16
AD539J Chip	0°C to +70°C	Chip	
AD539SD	-55°C to +125°C	Side Brazed DIP	D-16
AD539SD/883B	-55°C to +125°C	Side Brazed DIP	D-16
5962-8980901EA <sup>1</sup>	-55°C to +125°C	Side Brazed DIP	D-16
AD539SE/883B	-55°C to +125°C	LCC	E-20A

## NOTE

<sup>1</sup>The standard military drawing version of the AD539 (5962-8980901EA) is now available.

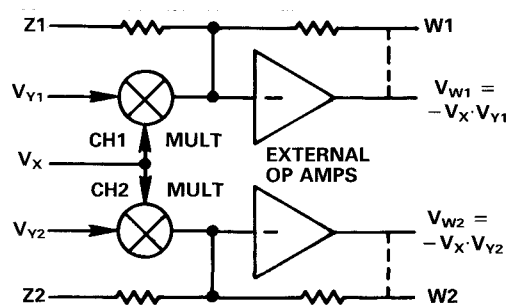

AD539 Functional Block Diagram

## CIRCUIT DESCRIPTION

Figure 1 is a simplified schematic of the AD539. Q1-Q6 are large-geometry transistors designed for low distortion and low noise. Emitter-area scaling further reduces distortion: Q1 is 3 times larger than Q2; Q4, Q5 are each 3 times larger than Q3, Q6, and these transistors are twice as large as Q1, Q2. A stable reference current  $I_{REF} = 1.375\text{mA}$  is produced by a band-gap reference circuit and applied to the common emitter node of a controlled-cascode formed by Q1 and Q2. When  $V_X = 0$ , all of  $I_{REF}$  flows in Q1, due to the action of the high-gain control amplifier which lowers the voltage on the base of Q2. As  $V_X$  is raised the fraction of  $I_{REF}$  flowing in Q2 is forced to balance the control current,  $V_X/2.5\text{k}$ . At the full-scale value of  $V_X (+3\text{V})$  this fraction is 0.873. Since the bases of Q1, Q4 and Q5 are at ground potential and the bases of Q2, Q3 and Q6 are commoned, all three controlled-cascodes divide the current applied to their emitter nodes in the same proportion. The control loop is stabilized by the external capacitor,  $C_C$ .

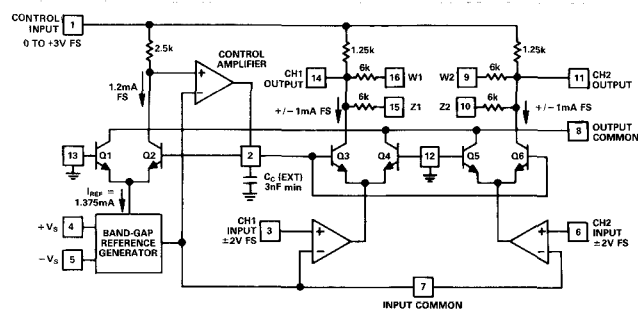

Figure 1. Simplified Schematic of AD539 Multiplier

The signal voltages  $V_{Y1}$  and  $V_{Y2}$  (generically referred to as  $V_Y$ ) are first converted to currents by voltage-to-current converters with a  $g_m$  of  $575\mu\text{mhos}$ ; thus, the full-scale input of  $\pm 2\text{V}$  becomes a current of  $\pm 1.15\text{mA}$ , which is superimposed on a bias of  $2.75\text{mA}$ , and applied to the common emitter node of controlled cascode Q3-Q4 or Q5-Q6. As just explained, the proportion of this current steered to the output node is linearly dependent on  $V_X$ . Thus for full-scale  $V_X$  and  $V_Y$  inputs, a signal of  $\pm 1\text{mA}$  ( $0.873 \times \pm 1.15\text{mA}$ ) and a bias component of  $2.4\text{mA}$  ( $0.873 \times 2.75\text{mA}$ ) appear at the output. The bias component absorbed by the  $1.25\text{k}$  resistors also connected to  $V_X$ , and the resulting signal current can be applied to an external load resistor (in which case scaling is not accurate) or can be forced into either or both of the  $6\text{k}\Omega$  feedback resistors (to the Z and W nodes) by an external op amp. In the latter case, scaling accuracy is guaranteed.

## GENERAL RECOMMENDATIONS

The AD539 is a high speed circuit and requires considerable care to achieve its full performance potential. A high-quality ground plane should be used with the device either soldered directly into the board or mounted in a low-profile socket. In the figures used here an open triangle denotes a direct, short connection to this ground plane; pins 12 and 13 are especially prone to unwanted signal pick-up. Power supply decoupling capacitors of  $0.1\mu\text{F}$  to  $1\mu\text{F}$  should be connected from pins 4 and 5 to the ground plane. In applications using external high-speed op amps, separate supply decoupling should be used. It is good practice to insert small ( $10\Omega$ ) resistors between the primary supply and the decoupling capacitor.

The control amplifier compensation capacitor,  $C_C$ , should likewise have short leads to ground and a minimum value of  $3\text{nF}$ . Unless maximum control bandwidth is essential it is advisable to use a larger value of  $0.01\mu\text{F}$  to  $0.1\mu\text{F}$  to improve the signal channel phase response, high-frequency crosstalk and high-frequency distortion. The control bandwidth is inversely proportional to this capacitance, typically  $2\text{MHz}$  for  $C_C = 0.01\mu\text{F}$ ,  $V_X = 1.7\text{V}$ . The bandwidth and pulse response of the control channel can be improved by using a feedforward capacitor of 5% to 20% the value of  $C_C$  between pins 1 and 2. Optimum transient response will result when the rise/fall time of  $V_X$  are commensurate with the control-channel response time.

$V_X$  should not exceed the specified range of 0 to  $+3\text{V}$ . The ac gain is zero for  $V_X < 0$  but there remains a feedforward path (see Figure 1) causing control feedthrough. Recovery time from negative values of  $V_X$  can be improved by adding a small-signal Schottky diode with its cathode connected to pin 2 and its anode grounded. This constrains the voltage swing on  $C_C$ . Above  $V_X = +3.2\text{V}$ , the ac gain limits at its maximum value, but any overdrive appears as control feedthrough at the output.

The power supplies to the AD539 can be as low as  $\pm 4.5\text{V}$  and as high as  $\pm 16.5\text{V}$ . The maximum allowable range of the signal inputs,  $V_Y$ , is approximately  $0.5\text{V}$  above  $+V_S$ ; the minimum value is  $2.5\text{V}$  above  $-V_S$ . To accommodate the peak specified inputs of  $\pm 4.2\text{V}$  the supplies should be nominally  $+5\text{V}$  and  $-7.5\text{V}$ . While there is no performance advantage in raising supplies above these values, it may often be convenient to use the same supplies as for the op amps. The AD539 can tolerate the excess voltage with only a slight effect on dc accuracy but dissipation at  $\pm 16.5\text{V}$  can be as high as  $535\text{mW}$  and some form of heat-sink is essential in the interests of reliability.

## AD539

### TRANSFER FUNCTION

In using any analog multiplier or divider careful attention must be paid to the matter of *scaling*, particularly in computational applications. To be *dimensionally consistent* a scaling voltage must appear in the transfer function, which, for each channel of the AD539 in the standard multiplier configuration (Figure 2) is

$$V_W = -V_X V_Y / V_U$$

where the inputs  $V_X$  and  $V_Y$ , the output  $V_W$  and the scaling voltage  $V_U$  are expressed in a consistent unit, usually volts. In this case,  $V_U$  is fixed by the design to be 1V and it is often acceptable in the interest of simplification to use the less rigorous expression

$$V_W = -V_X V_Y$$

where it is understood that *all signals must be expressed in volts*, that is, they are rendered dimensionless by division by (1V).

The accuracy specifications for  $V_U$  allow the use of either of the two feedback resistors supplied with each channel, since these are very closely matched, or they may be used in parallel to halve the gain (double the effective scaling voltage), when

$$V_W = -V_X V_Y / 2.$$

When an external load resistor,  $R_L$ , is used the scaling is no longer exact since the internal thin-film resistors, while trimmed to high *ratimetric* accuracy, have an absolute tolerance of 20%. However, the nominal transfer function is

$$V_W = -V_X V_Y / V_U'$$

where the effective scaling voltage,  $V_U'$  can be calculated for each channel using the formula  $V_U' = V_U (5R_L + 6.25) / R_L$ , where  $R_L$  is expressed in kilohms. For example, when  $R_L = 100\Omega$ ,  $V_U' = 67.5V$ . Table II provides more detailed data for the case where both channels are used in parallel. The AD539 can also be used with no external load (output pin 11 or 14 open-circuit), when  $V_U'$  is quite accurately 5V.

### BASIC MULTIPLIER CONNECTIONS

Figure 2 shows the connections for the standard two-channel multiplier, using op amps to provide useful output power and the AD539 feedback resistors to achieve accurate scaling. The transfer function for each channel is

$$V_W = -V_X V_Y$$

where inputs and outputs are expressed in volts (see TRANSFER FUNCTION). At the nominal full-scale inputs of  $V_X = +3V$ ,  $V_Y = \pm 2V$  the full-scale outputs are  $\pm 6V$ . Depending on the choice of op amp, their supply voltages usually need to be about 2V more than the peak output. Thus, supplies of at least  $\pm 8V$  are required; the AD539 can share these supplies. Higher outputs are possible if  $V_X$  and  $V_Y$  are driven to their peak values of

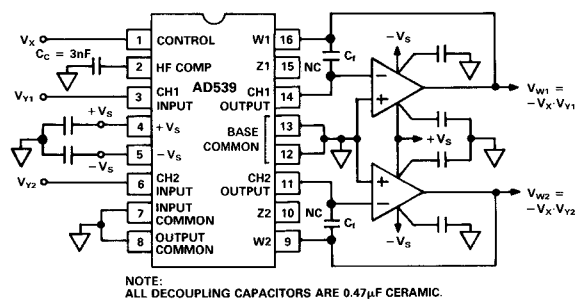

Figure 2. Standard Dual-Channel Multiplier

+3.2V and  $\pm 4.2V$  respectively, when the peak output is  $\pm 13.4V$ . This requires operating the op amps at supplies of  $\pm 15V$ . Under these conditions it is advisable to reduce the supplies to the AD539 to  $\pm 7.5V$  to limit its power dissipation; however, with some form of heat sinking it is permissible to operate the AD539 directly from  $\pm 15V$  supplies.

Viewed as a voltage-controlled amplifier, the decibel gain is simply

$$G = 20 \log V_X$$

where  $V_X$  is expressed in volts. This results in a gain of 10dB at  $V_X = +3.162V$ , 0dB at  $V_X = +1V$ , -20dB at  $V_X = +0.1V$ , and so on. In many ac applications the output offset voltage (for  $V_X = 0$  or  $V_Y = 0$ ) will not be of major concern; however, it can be eliminated using the offset nulling method recommended for the particular op amp, with  $V_X = V_Y = 0$ .

At small values of  $V_X$  the offset voltage of the control channel will degrade the gain/loss accuracy. For example, a  $\pm 1mV$  offset uncertainty will cause the nominal 40dB attenuation at  $V_X = +0.01V$  to range from 39.2dB to 40.9dB. Figure 3a shows the maximum gain error boundaries based on the guaranteed control-channel offset voltages of  $\pm 2mV$  for the AD539K and  $\pm 4mV$  for the AD539J. These curves include all scaling errors and apply to all configurations using the internal feedback resistors (W1 and W2; alternatively, Z1 and Z2).

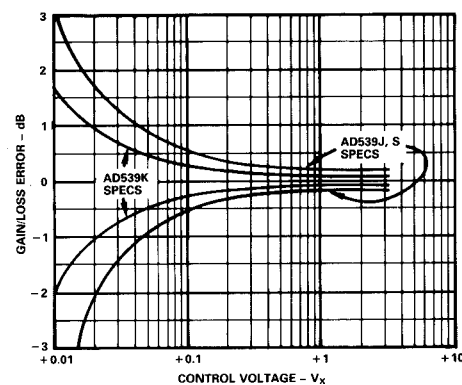

Figure 3a. Maximum AC Gain Error Boundaries

Distortion is a function of the signal input level ( $V_Y$ ) and the control input ( $V_X$ ). It is also a function of frequency, although in practice the op amp will generate most of the distortion at frequencies above 100kHz. Figure 3b shows typical results at  $f = 10kHz$  as a function of  $V_X$  with  $V_Y = 0.5$  and 1.5V rms.

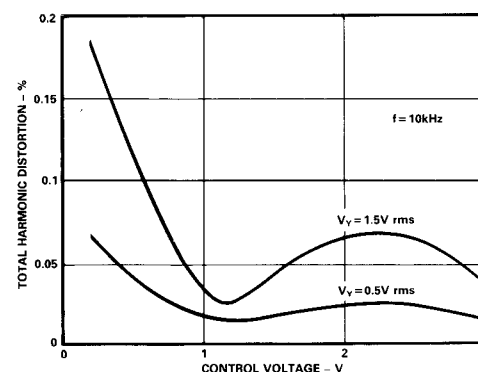

Figure 3b. Total Harmonic Distortion vs. Control Voltage

In some cases it may be desirable to alter the scaling. This can be achieved in several ways. One option is to use both the Z and W feedback resistors (see Figure 1) in parallel, in which case  $V_W = -V_X V_Y / 2$ . This may be preferable where the output swing must be held at  $\pm 3V$  FS ( $\pm 6.75V$  pk), for example, to allow the use of reduced supply voltages for the op amps. Alternatively, the gain can be doubled by connecting both channels in parallel and using only a single feedback resistor, in which case  $V_W = -2V_X V_Y$  and the full-scale output is  $\pm 12V$ . Another option is to insert a resistor in series with the control-channel input, permitting the use of a large (for example, 0 to +10V) control voltage. A disadvantage of this scheme is the need to adjust this resistor to accommodate the tolerance of the nominal  $500\Omega$  input resistance at pin 1. The signal channel inputs can also be resistively attenuated to permit operation at higher values of  $V_Y$ , in which case it may often be possible to partially compensate for the response roll-off of the op amp by adding a capacitor across the upper arm of this attenuator.

#### Signal-Channel ac and Transient Response

The HF response is dependent almost entirely on the op amp. Note that the "noise gain" for the op amp in Figure 2 is determined by the value of the feedback resistor ( $6k\Omega$ ) and the  $1.25k\Omega$  control-bias resistors (Figure 1). Op amps with provision for external frequency compensation (such as the AD301 and AD518) should be compensated for a closed-loop gain of 6.

The layout of the circuit components is very important if low feedthrough and flat response at low values of  $V_X$  is to be maintained (see GENERAL RECOMMENDATIONS).

For wide-bandwidth applications requiring an output voltage swing greater than  $\pm 1V$ , the LH0032 hybrid op-amp is recommended. Figure 4a shows the HF response of the circuit of

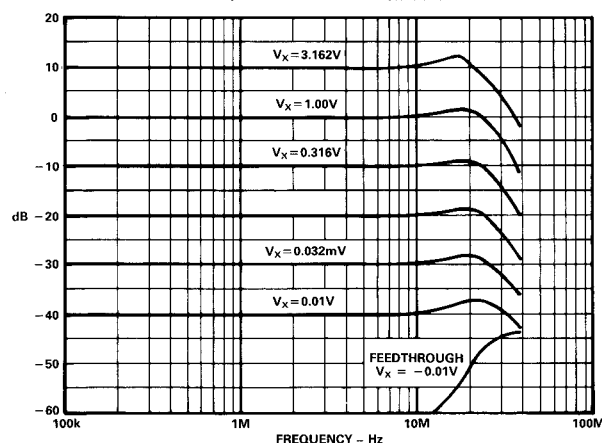

Figure 4a. Multiplier HF Response Using LH0032 Op Amps

Figure 2 using this amplifier with  $V_Y = 1V$  rms and other conditions as shown in Table I.  $C_F$  was adjusted for 1dB peaking at  $V_X = +1V$ ; the  $-3dB$  bandwidth exceeds 25MHz. The effect of signal feedthrough on the response becomes apparent at  $V_X = +0.01V$ . The minimum feedthrough results when  $V_X$  is taken slightly negative to ensure that the residual control-channel offset is exceeded and the dc gain is reliably zero. Measurements show that the feedthrough can be held to  $-90dB$  relative to full output at low frequencies and to  $-60dB$  up to 20MHz with careful board layout. The corresponding pulse response is shown in Figure 4b for a signal input of  $V_Y$  of  $\pm 1V$  and two values of  $V_X$  ( $+3V$  and  $+0.1V$ ).

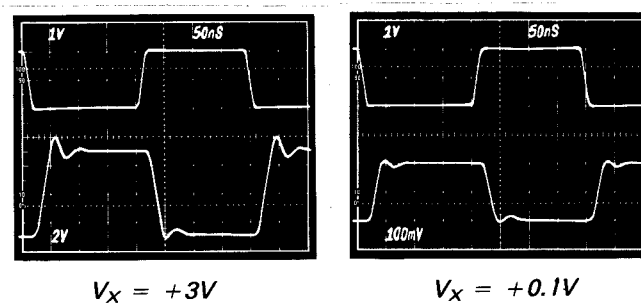

Figure 4b. Multiplier Pulse Response Using LH0032 Op Amps

	AD711 <sup>1</sup>	AD5539 <sup>2</sup>	LH0032 <sup>1</sup>
Op Amp Supply Voltages	$\pm 15V$	$\pm 9V$	$\pm 10V$
Op Amp Compensation Capacitor	None	None	1-5pF
Feedback Capacitor, $C_F$	None	0.25-1.5pF	1-4pF
$-3dB$ Bandwidth, $V_X = +1V$	900kHz	50MHz	25MHz
Load Capacitance	$< 1nF$	$< 10pF$	$< 100pF$
HF Feedthrough, $V_X = -0.01V, f = 5MHz$	N/A	$-54dB$	$-70dB$
rms Output Noise, $V_X = +1V, BW 10Hz-10kHz$	$50\mu V$	$40\mu V$	$30\mu V$
$V_X = +1V, BW 10Hz-5MHz$	$120\mu V$	$620\mu V$	$500\mu V$

In all cases,  $0.47\mu F$  ceramic supply-decoupling capacitors were used at each IC pin, the AD539 supplies were  $\pm 5V$  and the control-compensation capacitor  $C_C$  was  $3nF$ .

#### NOTES

<sup>1</sup>For the circuit of Figure 2.

<sup>2</sup>For the circuit of Figure 8.

Table I. Summary of Operating Conditions and Performance for the AD539 When Used with Various External Op-Amp Output Amplifiers

#### Minimal Wide-Band Configurations

The maximum bandwidth can be achieved using the AD539 with simple resistive loads to convert the output currents to voltages. These currents (nominally  $\pm 1mA$  FS,  $\pm 2.25mA$  pk,

Table II. Summary of Performance for Minimal Configuration

Load Resistance	50 $\Omega$	75 $\Omega$	100 $\Omega$	150 $\Omega$	600 $\Omega$	O/C
FS Output Voltage	$\pm 92.6mV$ 65.5mV rms	$\pm 134mV$ 94.7mV rms	$\pm 172mV$ 122mV rms	$\pm 242mV$ 171mV rms	$\pm 612mV$ 433mV rms	$\pm 1V$ *
FS Output- Power in Load	0.086mW -10.5dBm	0.12mW -9.2dBm	0.15mW -8.3dBm	0.195mW -7.1dBm	0.312mW -5.05dBm	-
Pk Output Voltage	$\pm 210mV$ 148mV rms	$\pm 300mV$ 212mV rms	$\pm 388mV$ 274mV rms	$\pm 544mV$ 385mV rms	$\pm 1V$ *	$\pm 1V$ *
Pk Output- Power in Load	0.44mW -7dBm	0.6mW -4.4dBm	0.75mW -2.5dBm	1mW 0dBm	$\pm 1V$ *	$\pm 1V$ *
Effective Scaling Voltage, $V_U'$	67.5V	46.7V	36.3V	25.8V	10.2V	5V

\*Peak negative voltage swing limited by output compliance.

## AD539

into short-circuit loads) are shunted by their source resistance of  $1.25\text{k}\Omega$  (each channel). Calculations of load power and effective scaling-voltage must allow for this shunting effect when using resistive loads. The output power is quite low in this mode, and the device behaves more like a voltage-controlled attenuator than a classical multiplier. The matching of gain and phase between the two channels is excellent. From dc to  $10\text{MHz}$  the gains are typically within  $\pm 0.025\text{dB}$  (measured using precision  $50\Omega$  load resistors) and the phase difference within  $\pm 0.1^\circ$ .

For a given load resistance the output power can be quadrupled by using both channels in parallel, as shown in Figure 5a. The small-signal silicon diode D connected between ground and pins 12 and 13 provides extra voltage compliance at the output nodes in the negative direction (to  $-1\text{V}$  at  $25^\circ\text{C}$ ); it is not required if the output swing does not exceed  $-300\text{mV}$ . Table II compares performance for various load resistances, using this configuration.

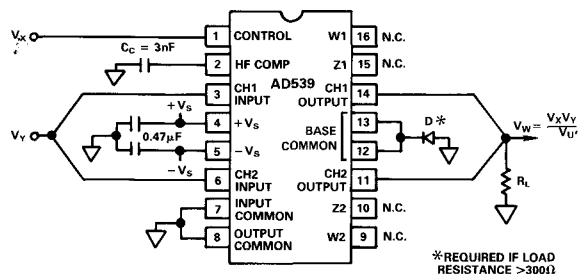

Figure 5a. Minimal Single-Channel Multiplier

Figure 5b shows the HF response for Figure 5a with the AD539 in a carefully-shielded  $50\Omega$  test-environment; the test system response was first characterized and this background removed by digital signal processing to show the inherent circuit response.

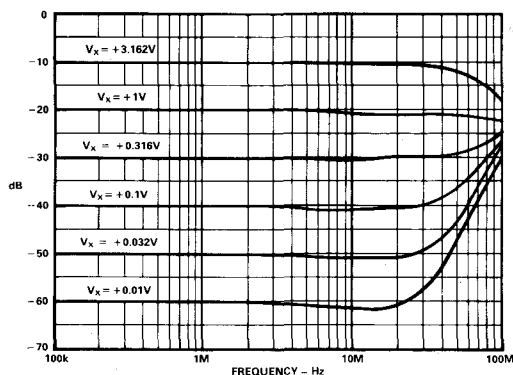

Figure 5b. HF Response in Minimal Configuration

In many applications *phase linearity* over frequency is important. Figure 5c shows the deviation from an ideal linear-phase response for a typical AD539 over the frequency range dc to  $10\text{MHz}$ , for  $V_x = +3\text{V}$ ; the peak deviation is slightly more than  $1^\circ$ . *Differential phase linearity* (the stability of phase over the signal window at a fixed frequency) is shown in Figure 5d for  $f = 3.579\text{MHz}$  and various values of  $V_x$ . The most rapid variation occurs for  $V_x$  above  $+1\text{V}$ ; in applications where this characteristic is critical, it is recommended that a ground-referenced, negative-going signal be used.

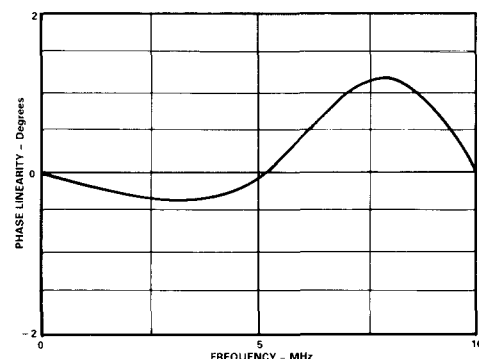

Figure 5c. Phase Linearity Error in Minimal Configuration

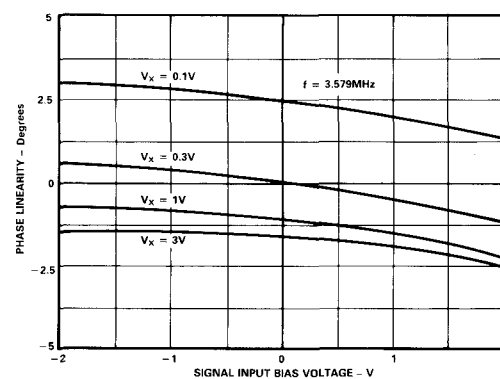

Figure 5d. Differential Phase Linearity in Minimal Configuration for a Typical Device

### Differential Configurations

When only one signal channel must be handled it is often advantageous to use the channels differentially. By subtracting the CH1 and CH2 outputs any residual transient control feedthrough is virtually eliminated. Figure 6a shows a minimal configuration where it is assumed that the host system uses differential signals and a  $50\Omega$  environment throughout. This figure also shows a recommended control-feedforward network to improve large-signal

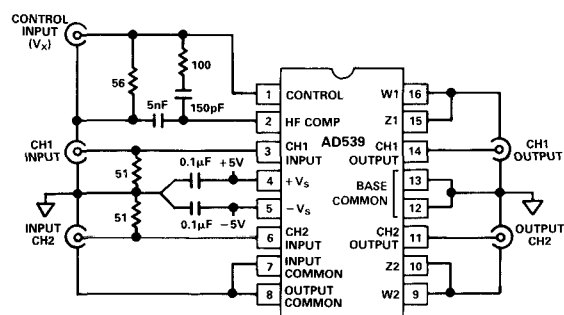

Figure 6a. High-Speed Differential Configuration

response time. The control feedthrough glitch is shown in Figure 6b, where the input was applied to CH1 and only the output of CH1 was displayed on the oscilloscope. The improvement obtained when CH1 and CH2 outputs are viewed differentially is clear in Figure 6c. The envelope rise-time is of the order of  $40\text{ns}$ .

Lower distortion results when CH1 and CH2 are driven by *complementary* inputs and the outputs are utilized differentially, using a circuit such as Figure 7a. Resistors R1 and R2 should have a value in the range  $100$  to  $1000\Omega$ .

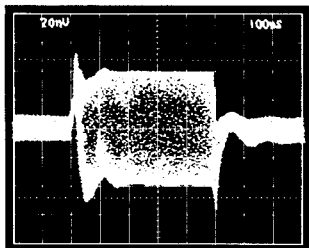

Figure 6b. Control Feed-through One Channel of Figure 6a

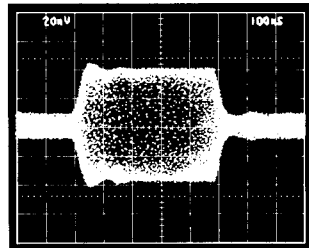

Figure 6c. Control Feed-through Differential Mode, Figure 6a

They minimize a secondary distortion mechanism caused by a collector-modulation effect in the controlled cascodes (see CIRCUIT DESCRIPTION) by keeping the voltage-swing at the outputs to an acceptable level. Figure 7b shows the improvement in distortion over the standard configuration (compare Figure 3b). Note that the Z nodes (pins 10 and 15) are returned to the control input; this prevents the early onset of output-transistor saturation.

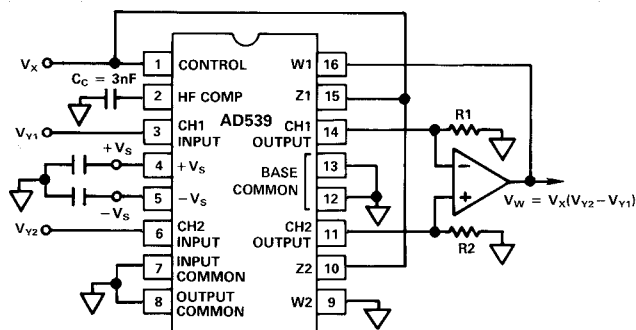

Figure 7a. Low-Distortion Differential Configuration

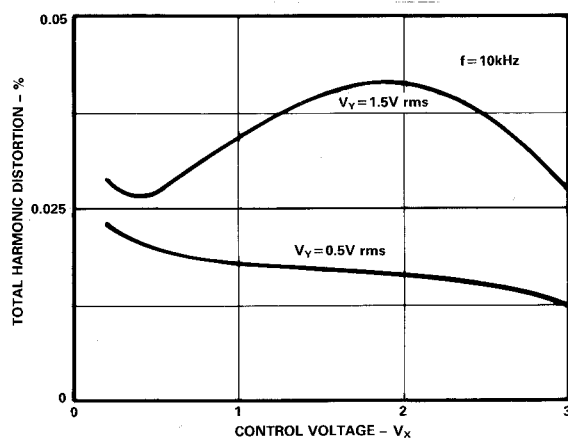

Figure 7b. Distortion in Differential Mode Using LH0032 Op Amp

Even lower distortion (0.01%, or -80dB) has been measured using two output op amps in a configuration similar to Figure 2 connected as virtual-ground current-summers (to prevent the modulation effect). Note that to generate the difference output it is merely necessary to connect the output of the CH1 op amp to the Z node of CH2. In this way, the net input to the CH2 op amp is the difference signal, and the low-distortion resultant appears as its output.

REV. A

**A 50MHz VOLTAGE-CONTROLLED AMPLIFIER**

Figure 8 is a circuit for a 50MHz voltage-controlled amplifier (VCA) suitable for use in high-quality-video-speed applications. The outputs from the two-signal channels of the AD539 are applied to the op-amp in a subtracting configuration. This connection has two main advantages: first, it results in better rejection of the control voltage, particularly when over-driven ( $V_X < 0$  or  $V_X > 3.3V$ ). Secondly, it provides a choice of either non-inverting or inverting responses, using either inputs  $V_{Y1}$  or  $V_{Y2}$  respectively. In this circuit, the output of the op-amp will equal:

$$V_{OUT} = \frac{V_X (V_{Y1} - V_{Y2})}{2V} \text{ for } V_X > 0$$

Hence, the gain is unity at  $V_X = +2V$ . Since  $V_X$  can over-range to +3.3V, the maximum gain in this configuration is about 4.3dB. (Note: If pin 9 of the AD539 is grounded, rather than connected to the output of the 5539N, the maximum gain becomes 10dB.)

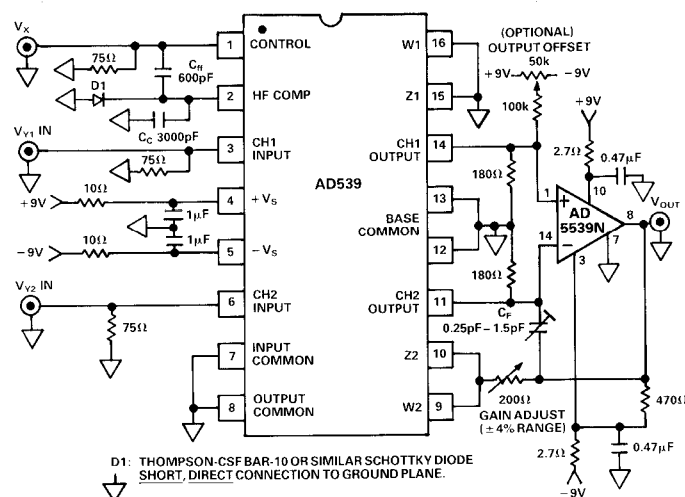

Figure 8. A Wide Bandwidth Voltage-Controlled Amplifier

The -3dB bandwidth of this circuit is over 50MHz at full gain, and is not substantially affected at lower gains. Of course, when  $V_X$  is zero (or slightly negative, to override the residual input offset) there is still a small amount of capacitive feedthrough at high frequencies; therefore, extreme care is needed in laying out the PC board to minimize this effect. Also, for small values of  $V_X$ , the combination of this feedthrough with the multiplier output can cause a dip in the response where they are out of phase. Figure 9a shows the ac response from the noninverting

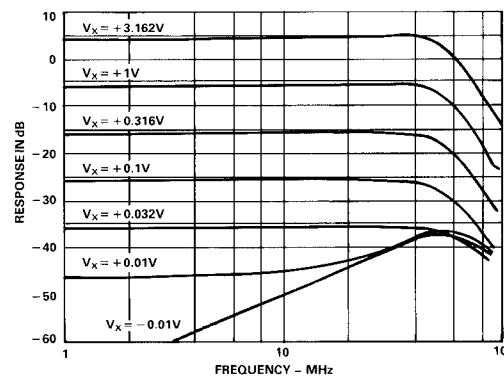

Figure 9a. AC Response of the VCA at Different Gains  $V_Y = 0.5V$  RMS

## AD539

input, with the response from the inverting input,  $V_{Y2}$ , essentially identical. Test conditions:  $V_{Y1} = 0.5V$  rms for values of  $V_X$  from  $+10mV$  to  $+3.16V$ ; this is with a  $75\Omega$  load on the output. The feedthrough at  $V_X = -10mV$  is also shown.

The transient response of the signal channel at  $V_X = +2V$ ,  $V_Y = V_{OUT} = \pm 1V$  is shown in Figure 9b; with the VCA driving a  $75\Omega$  load. The rise and fall times are approximately  $7ns$ .

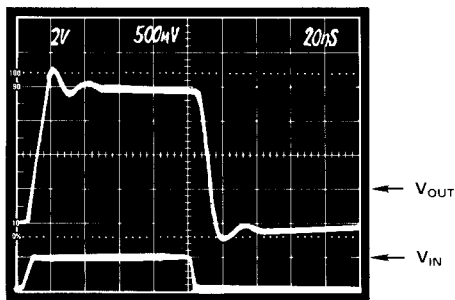

Figure 9b. Transient Response of the Voltage-Controlled Amplifier  $V_X = +2$  Volts  $V_Y = \pm 1$  Volt

A more detailed description of this circuit, including differential gain and phase characteristics, is given in the application note "Low Cost, Two Chip Voltage-Controlled Amplifier and Video Switch" available from Analog Devices.

### BASIC DIVIDER CONNECTIONS

#### Standard Scaling

The AD539 provides excellent operation as a two-quadrant analog divider in wide-band wide gain-range applications, with the advantage of dual-channel operation. Figure 10a shows the simplest connections for division with a transfer function of

$$V_Y = -V_U V_W / V_X$$

Recalling that the nominal value of  $V_U$  is  $1V$ , this can be simplified to

$$V_Y = -V_W / V_X$$

where all signals are expressed in volts. The circuit thus exhibits unity gain for  $V_X = +1V$  and a gain of  $40dB$  when  $V_X = +0.01V$ .

The output swing is limited to  $\pm 2V$  nominal full-scale and  $\pm 4.2V$  peak (using a  $-V_S$  supply of at least  $7.5V$  for the AD539). Since the maximum loss is  $10dB$  (at  $V_X = 3.162V$ ), it follows that the maximum input to  $V_W$  should be  $\pm 6.3V$  ( $4.4V$  rms)

#### PACKAGE DIMENSIONS

Dimensions shown in inches and (mm).

#### 16-Pin Plastic (N) Package

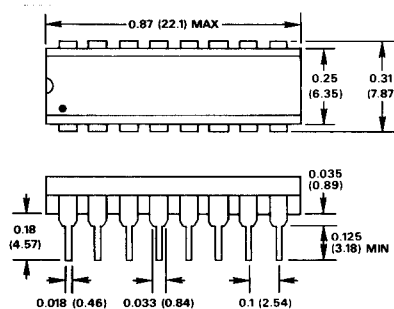

#### TO-116 Ceramic (D) Package

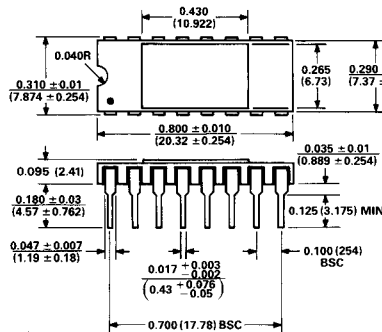

#### 20-Pin LCC (E) Package

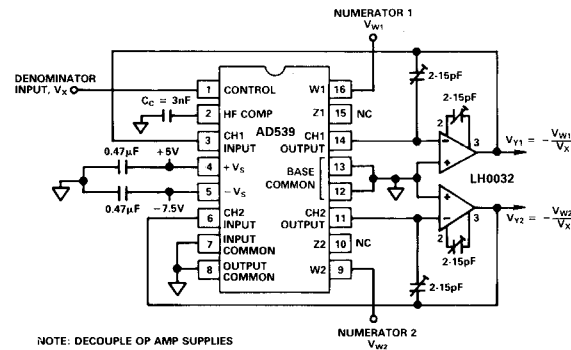
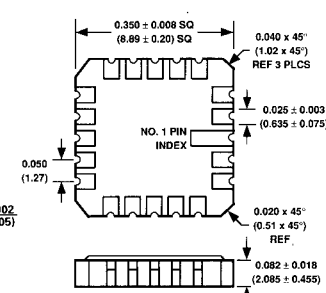

Figure 10a. Two-Channel Divider with 1V Scaling

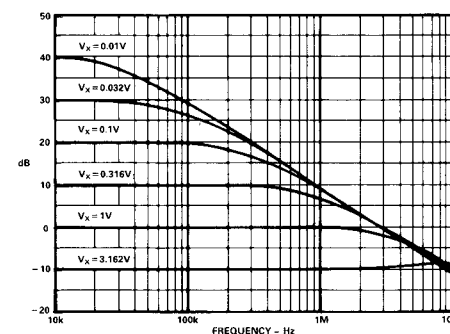

Figure 10b. HF Response of Figure 10a Divider

for low distortion applications, and no more than  $\pm 13.4V$  ( $9.5V$  rms) to avoid clipping. Note that offset adjustment will be needed for the op amps to maintain accurate dc levels at the output in high gain applications: the "noise gain" is  $6V/V_X$ , or  $600$  at  $V_X = +0.01V$ .

The gain-magnitude response for this configuration using the LH0032 op amps with nominally  $12pF$  compensation (pins 2 to 3) and  $C_F = 7pF$  is shown in Figure 10b; of course, other amplifiers may also be used. Since there is some manufacturing variation in the HF response of the op amps, and load conditions will also affect the response, these capacitors should be adjustable:  $5-15pF$  is recommended for both positions. The bandwidth in this configuration is nominally  $17MHz$  at  $V_X = +3.162V$ ,  $4.5MHz$  at  $V_X = +1V$ ,  $350kHz$  at  $V_X = +0.1V$  and  $35kHz$  at  $V_X = +0.01V$ . The general recommendations regarding the use of a good ground plane and power-supply decoupling should be carefully observed. Other suitable high speed op amps include: AD844, AD827 and AD811. Consult these data sheets for suitable applications circuits.