

# 2-phase motor driver for VCR cylinder motors

## BA6970FS

The BA6970FS is a direct-drive motor driver suitable for 2-phase, full-wave linear motors. The IC consists of a Hall amplifier control circuit, driver circuits, FG / PG signal amplifiers, and hysteresis amplifiers.

### ● Applications

VCR cylinder motors

### ● Features

- 1) Linear drive system provides low switching noise.
- 2) Output current can be controlled by either current or voltage input.
- 3) Two amplifiers and two hysteresis amplifiers.
- 4) Constant supply voltage pin for hall devices.
- 5) High ratio of output current and control current. (4000 typically)
- 6) Available in a compact surface-mount package.

### ● Block diagram

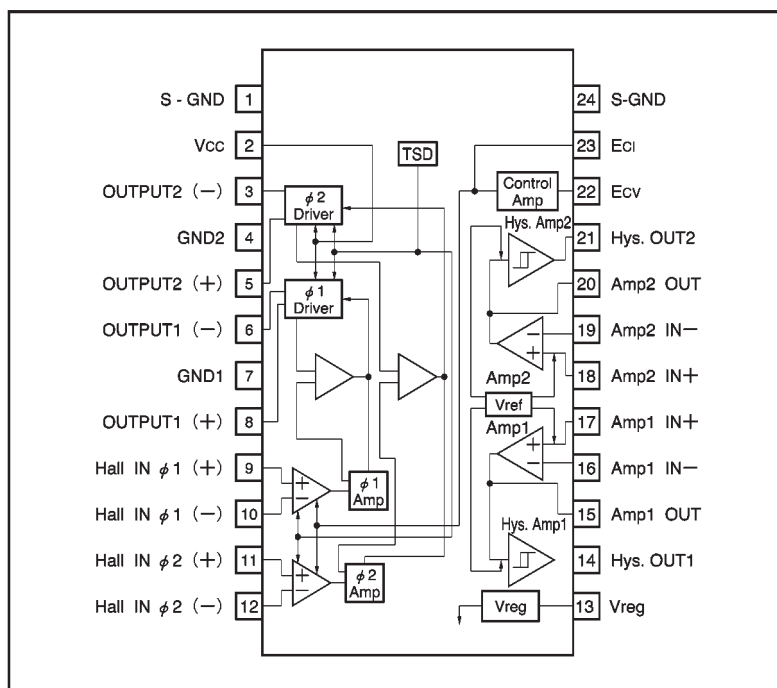

## ● Absolute maximum ratings (Ta = 25°C)

Parameter	Symbol	Limits	Unit
Applied voltage	V <sub>CC</sub>	18	V
Power dissipation	P <sub>d</sub>	1000* <sup>1</sup>	mW
Operating temperature	T <sub>opr</sub>	-25~+75	°C
Storage temperature	T <sub>stg</sub>	-55~+150	°C
Output current	I <sub>OMax.</sub>	1200* <sup>2</sup>	mA
Input current	I <sub>ECIMax.</sub>	5	mA

\*1 When mounted on a glass epoxy board (90×50×1.6 mm).

Reduced by 8 mW for each increase in Ta of 1°C over 25°C.

\*2 Should not exceed Pd or ASO values (for the current of one phase).

## ● Recommended operating conditions (Ta = 25°C)

Parameter	Symbol	Limits	Unit
Operating power supply voltage	V <sub>CC</sub>	8.0~16.0	V

●Electrical characteristics (unless otherwise noted, Ta = 25°C, Vcc = 12V)

Parameter	Symbol	Min.	Typ.	Max.	Unit	Conditions
Supply current	I <sub>CC</sub>	—	5.8	13.0	mA	—
Constant output voltage	V <sub>reg</sub>	4.6	5.0	5.4	V	—
〈MDA〉						
Hall element minimum input voltage	V <sub>INH</sub>	50	—	—	mV <sub>P-P</sub>	—
Hall input bias current	I <sub>BH</sub>	—	0.25	2.0	μA	I <sub>cont</sub> =100 μA
Output saturation high level voltage	V <sub>OH</sub>	10.45	10.79	—	V	I <sub>OUT</sub> =800mA
Output saturation low level voltage	V <sub>OL</sub>	—	1.33	2.16	V	I <sub>OUT</sub> =800mA
〈ECV (voltage control)〉						
Allowable torque command input voltage	E <sub>CV</sub>	0	—	V <sub>reg</sub>	V	—
Torque control voltage offset	E <sub>CV</sub> OFS	−150	0	150	mV	For 0.48 X V <sub>reg</sub>
Torque control input current	I <sub>ECVIN</sub>	—	1.0	6	μA	E <sub>CV</sub> =2.5V
Output standby current	I <sub>ECVidle</sub>	—	0	5	mA	E <sub>CV</sub> =2.5V
I/O gain	G <sub>ECV</sub>	0.38	0.55	0.64	A / V	Measured at E <sub>CV</sub> = 2.8 V, 3.3 V; ΔV <sub>IN</sub> = 100 mV
〈E <sub>CI</sub> (current control)〉						
Ratio of pin-23 current and output current	I <sub>OUT</sub> / I <sub>cont</sub>	3300	4000	4700	—	ΔV <sub>IN</sub> = 100 mV; measured at I <sub>cont</sub> = 30 μA, 50 μA
Output current differential	ΔI <sub>OUT</sub>	−30	0	30	mA	I <sub>cont</sub> =30 μA
〈Amp1, Amp2〉						
Input sink current	I <sub>INA</sub>	—	0.2	2.0	μA	V <sub>IN</sub> =2.5V
Open loop gain	G <sub>A</sub>	65	70	—	dB	f <sub>IN</sub> =500Hz
DC bias voltage variation	ΔV <sub>BA</sub>	−10	0	10	%	Variation from V <sub>reg</sub>
Output high level voltage	V <sub>OH A</sub>	V <sub>reg</sub> −1.48	V <sub>reg</sub> −0.72	—	V	I <sub>OH A</sub> =0.5mA
Output low level voltage	V <sub>OL A</sub>	—	0.85	1.45	V	I <sub>OL A</sub> =0.5mA
Input voltage of Amplifiers 1 and 2	V <sub>AB</sub>	1.2	—	4.0	V	—
〈Hys. Amp1, 2〉						
Hysteresis width	V <sub>hys</sub>	±142	±180	±218	mV	—
Output low level voltage	V <sub>OLhys</sub>	—	0.12	0.32	V	I <sub>OLhysA</sub> =2mA
Output pull-up resistance	V <sub>Bhys</sub>	7.0	10.0	13.0	kΩ	—

◎Not designed for radiation resistance.

## ● Pin descriptions

Pin No.	Pin name	Function
1	S—GND	Signal ground
2	V <sub>cc</sub>	Output current control
3	OUTPUT2 (—)	Output
4	GND2	OUTPUT2 GND
5	OUTPUT2 (+)	Output
6	OUTPUT1 (—)	Output
7	GND1	OUTPUT1 GND
8	OUTPUT1 (+)	Output
9	Hall IN $\phi$ 1 (+)	Hall signal input
10	Hall IN $\phi$ 1 (—)	Hall signal input
11	Hall IN $\phi$ 2 (+)	Hall signal input
12	Hall IN $\phi$ 2 (—)	Hall signal input
13	V <sub>reg</sub>	Constant voltage output
14	Hys.OUT1	Hysteresis amplifier 1 output
15	Amp1OUT	Amplifier 1 output ; hysteresis amplifier 1 input
16	Amp1IN—	Amplifier 1 input , inverted
17	Amp1IN+	Amplifier 1 input , non-inverted
18	Amp2IN+	Amplifier 2 input , non-inverted
19	Amp2IN—	Amplifier 2 input , inverted
20	Amp2OUT	Amplifier 2 output ; hysteresis amplifier 2 input
21	Hys.OUT2	Hysteresis amplifier 2 output
22	ECV	Output current control (voltage control)
23	ECl	Output current control (current control)
24	S—GND	Signal ground

● Input / output circuits

(1) E<sub>cv</sub> (22 pin)

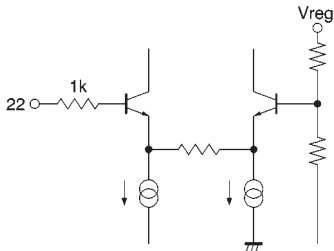

(All resistances, in  $\Omega$ , are typical values)

Fig.1

(2) Coil output (8, 6, 5, 3 pin)

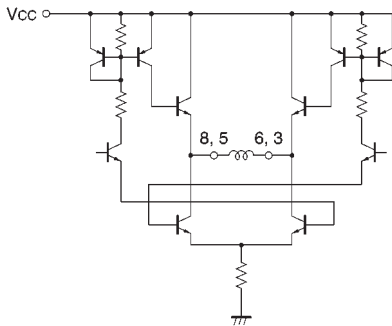

(All resistances, in  $\Omega$ , are typical values)

Fig.2

(3) Hall inputs (9, 10, 11, 12 pin), E<sub>ci</sub> input

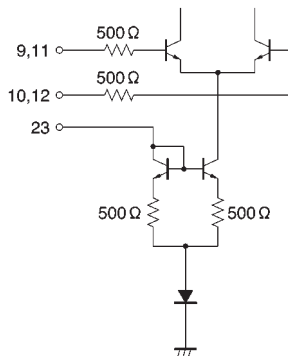

(All resistances, in  $\Omega$ , are typical values)

Fig.3

(4) I / O of amplifiers 1 and 2

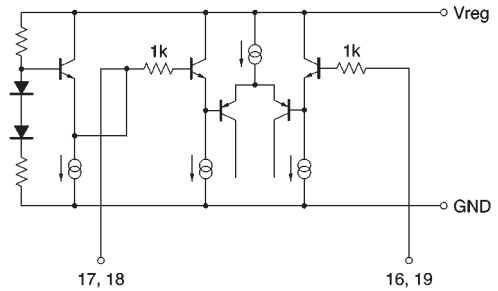

(All resistances, in  $\Omega$ , are typical values)

Fig.4

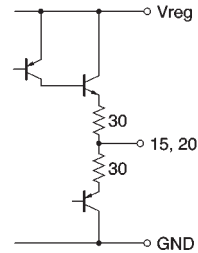

(5) I / O of hysteresis amplifiers

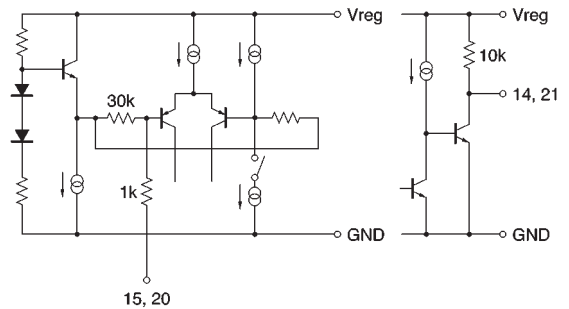

(All resistances, in  $\Omega$ , are typical values)

Fig.5

\*Note that the resistance values can vary  $\pm 30\%$

●Circuit operation

(1) The signal from the Hall device is amplified by the Hall amplifier and then supplied to the driver circuit. The driver gain, which is constant, is regulated by changing the Hall amplifier gain with the  $E_{Cl}$  input current or the  $E_{Cv}$  input voltage ( $E_{Cl}$  and  $E_{Cv}$  are output current control pins). The motor rotational speed is sensed by the FG, and the output from which is F / I-converted and supplied to the  $E_{Cl}$  pin or F / V-converted and supplied to the  $E_{Cv}$  pin as a feedback signal, so that a constant rotational speed is maintained as follows (Fig. 6) :

- 1) The motor speed decreases.
- 2) The speed control IC outputs a feedback signal
- 3) The Hall amplifier gain increases.
- 4) The output current increases.
- 5) The motor speed increases.

(2) When the voltage on Hall  $IN\phi_1 (+)$  is higher than the voltage on Hall  $IN\phi_1 (-)$ , an output current flows from  $OUTPUT1 (+)$  to  $OUTPUT1 (-)$  according to the voltage differential. When the voltage on Hall  $IN\phi_1 (-)$  is higher, on the other hand, an output current flows from  $OUTPUT1 (-)$  to  $OUTPUT1 (+)$ .

Similarly, when the voltage on Hall  $IN\phi_2 (+)$  is higher than the voltage on Hall  $IN\phi_2 (-)$ , an output current flows from  $OUTPUT2 (+)$  to  $OUTPUT2 (-)$  according to the voltage differential. When the voltage on Hall  $IN\phi_2 (-)$  is higher, on the other hand, an output current flows from  $OUTPUT2 (-)$  to  $OUTPUT2 (+)$ .

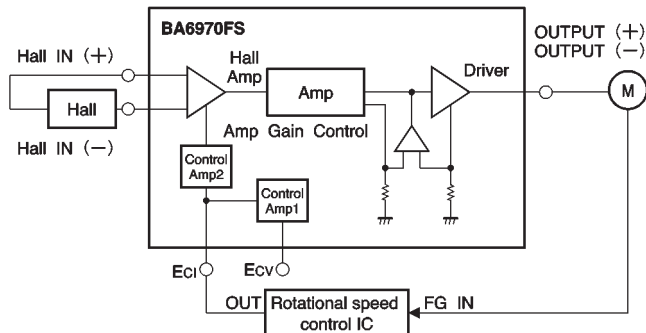

Fig.6

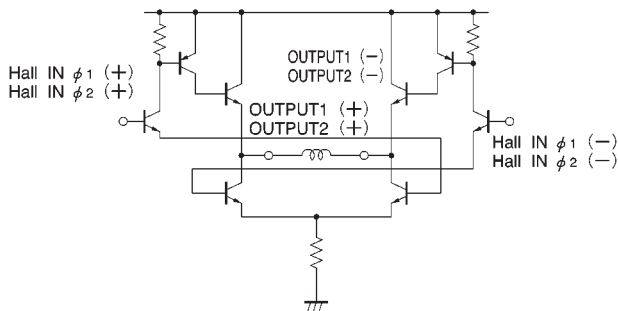

Fig.7

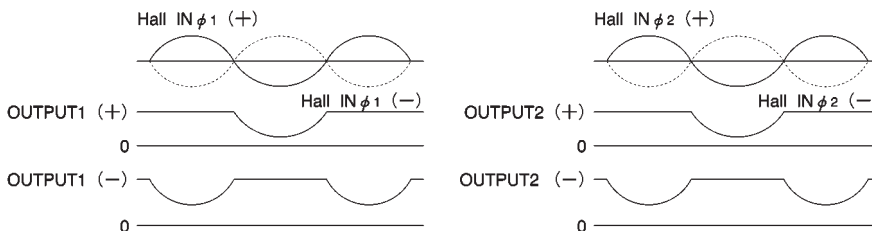

Fig.8

(3) Output waveforms are shown in Fig. 9. Because of the amplifier offset, the output is left OPEN when the output signal switches from positive to negative. The output waveform is determined by the external circuit because the IC impedance increases during this transition period. Since inductive loads are usually provided, a capacitor should be connected to suppress backlash voltages.

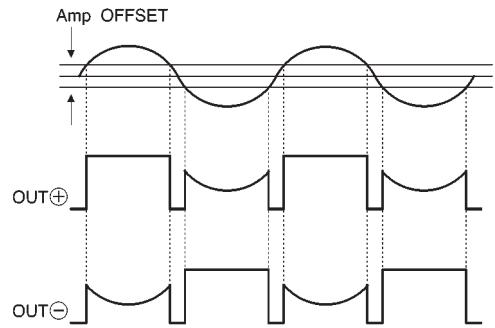

Fig.9

● Operation notes

(1)  $E_{cv}$  input (pin 22)

The  $E_{cv}$  input is plotted against the output current in Fig. 10.

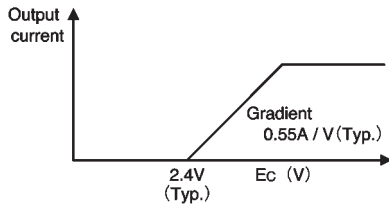

Fig.10

(2) Hall input

Hall input signals of 50mV (peak to peak) or greater should be applied between pins 9 and 10 and between pins 11 and 12. The DC input range is 2V to ( $V_{reg} - 1.5V$ ). There will be no problem if the input is centered around  $V_{reg} / 2$ .

Because the Hall input impedance is  $1M\Omega$  or greater, any type of Hall device can be connected. No current flows when the transistor is off because pins 9 and 10 as well as pins 11 and 12 are differential inputs.

Because the IC is a linear driver, any DC offset in the Hall device will be amplified and appear in the output. Use Hall devices having a minimum offset. Hall devices can be connected in either series or parallel.

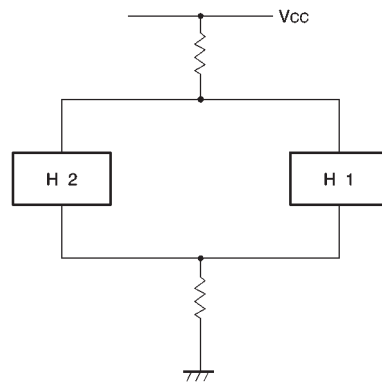

Parallel connection

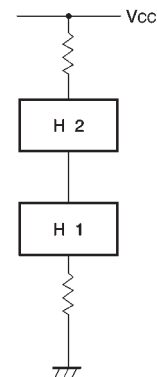

Series connection

Fig.11

(3)  $E_{CI}$  input

The  $E_{CI}$  input circuit has  $2V_F$  and a  $500\Omega$  resistor connected in series. Current is limited only by the  $500\Omega$  resistor.

(4) Amplifiers 1 and 2

An input range of  $0.6V$  to  $(V_{CC} - 1.2V)$  is recommended. Unpredictable outputs may occur when the input is outside this range.

(5) Hysteresis amplifier

An input range of  $0.6V$  to  $(V_{CC} - 1.2V)$  is recommended. Unpredictable outputs may occur when the input is outside this range.

(6) Thermal shutdown circuit

The thermal shutdown circuit puts the driver outputs (8, 6, 5, 3 pin) to the open state at the temperature of  $175^\circ C$  (typical). The circuit is deactivated when the temperature drops to about  $155^\circ C$ .

(7) Signal ground pin

Pins 1 and 24 are signal ground pins. Be noted that unpredictable outputs may occur if your application causes a large current between pins 1 and 24 via the bonding wire IC chip.

● Application example

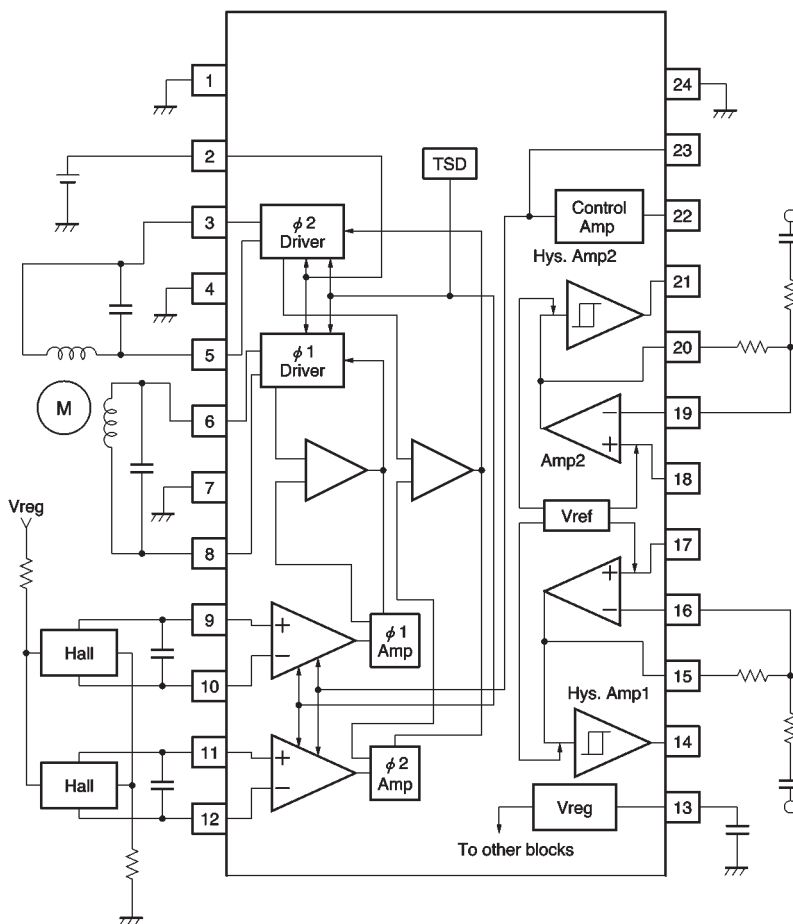

Fig.12



●Electrical characteristic curves

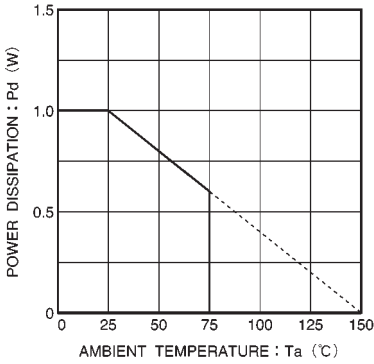

Fig.13 Thermal derating curve

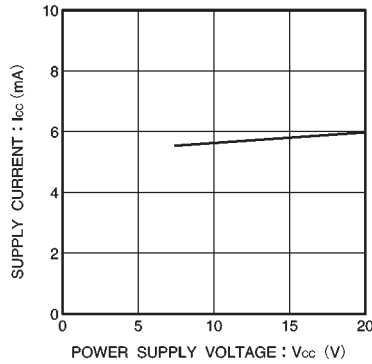

Fig.14 Supply current vs. power supply voltage

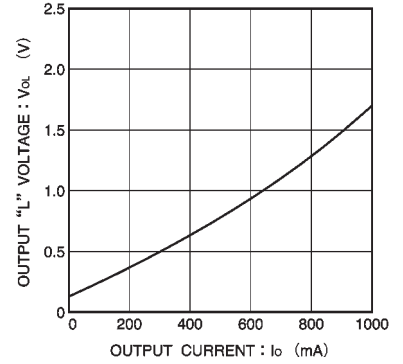

Fig.15 Output low level voltage vs. output current

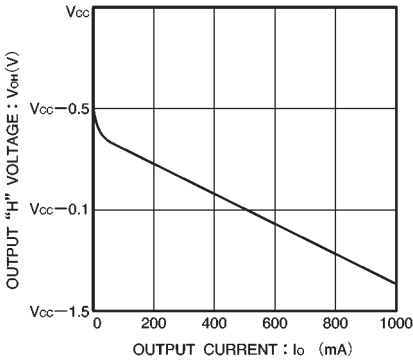
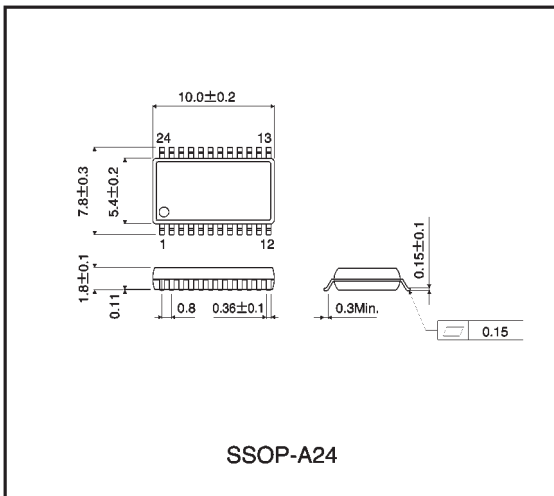

Fig.16 Output high level voltage vs. output current

●External dimensions (Units: mm)



SSOP-A24