

VCR standard audio signal processor

BA7796FS

The BA7796FS is a standard audio signal processor designed for use in VCRs and tape decks. The circuit is comprised of a playback preamplifier, a line amplifier, a recording amplifier, an ALC circuit, an EQ switch, and high-voltage head switch.

The IC has three input switching systems, and a built-in coil equivalent circuit for recording equalization, which eliminates the need for an external component.

●Applications

Video cassette recorders and tape decks

●Features

- 1) Three input switching systems built-in (LINE1, LINE2, and TUNER).
- 2) Built-in coil equivalent circuit for recording equalization.
- 3) Two-mode EQ switch.
- 4) High-performance low-noise playback amplifier.
- 5) Fixed ALC level (- 7.2dB when $V_{CC} = 12V$).
- 6) Phase-inverting recording amplifier.

●Absolute maximum ratings ($T_a = 25^\circ\text{C}$)

Parameter	Symbol	Limits	Unit
Power supply voltage	V_{CC}	13	V
Power dissipation	P_d	800*	mW
Operating temperature	T_{opr}	- 10 ~ + 65	$^\circ\text{C}$
Storage temperature	T_{stg}	- 55 ~ + 125	$^\circ\text{C}$

* When mounted on a 90mm × 50mm × 1.6mm glass epoxy board.
Reduced by 8.0mW for each increase in T_a of 1°C over 25°C .

●Recommended operating conditions ($T_a = 25^\circ\text{C}$)

Parameter	Symbol	Min.	Typ.	Max.	Unit
Power supply voltage	V_{CC}	7.5	—	12.5	V

●Block diagram

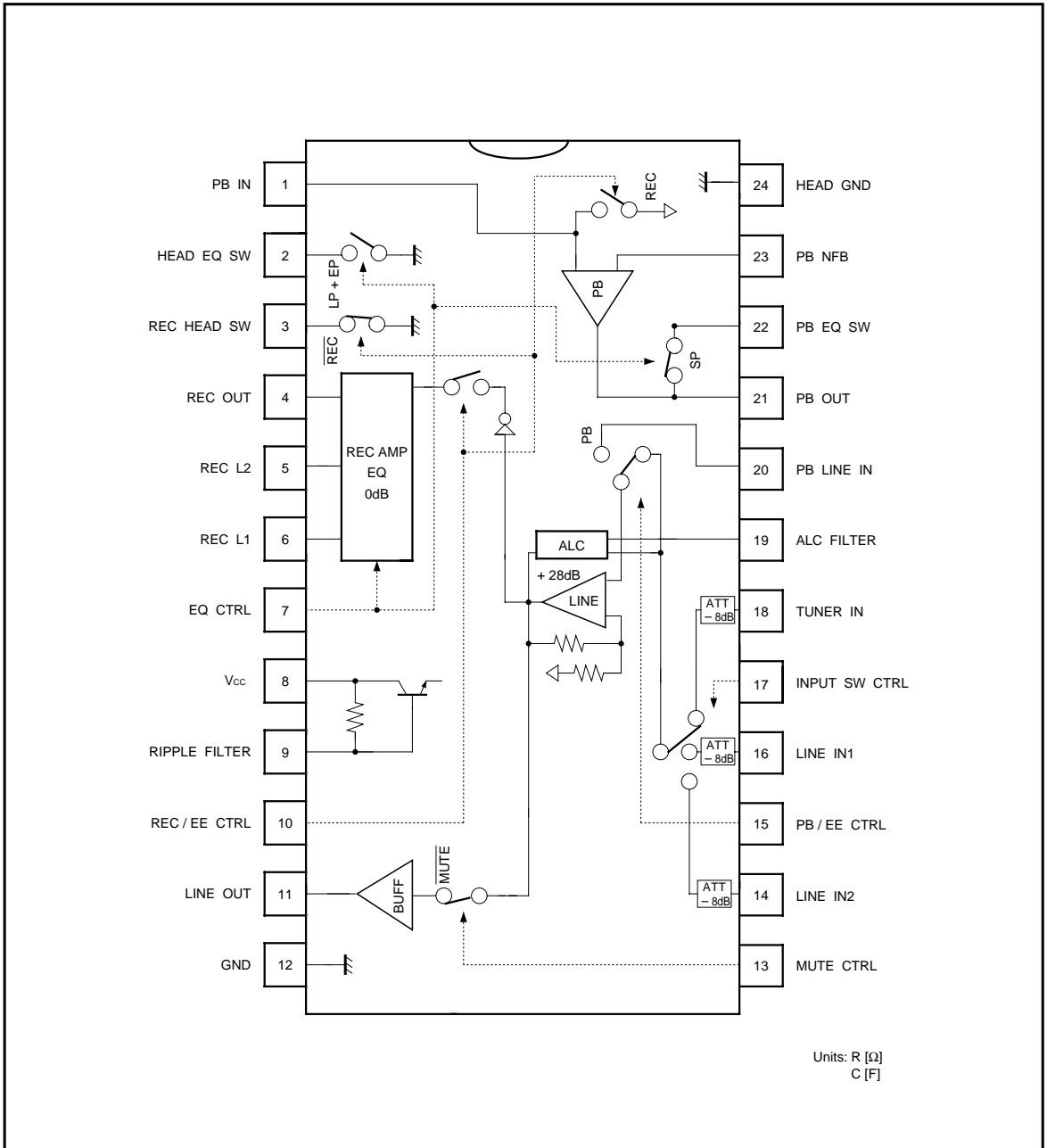

● Pin descriptions

Pin No.	Pin name	Function	Pin voltage	I / O circuit
1	PB IN	Playback amplifier input / playback head switch	2.0V	REC: 120kΩ REC: 11Ω
2	HEAD EQ SW	Head resonance capacitor switch	0.0V	220kΩ / 20Ω (ON)
3	REC HEAD SW	High-withstanding voltage recording head switch	0.0V	REC: 11Ω (ON) REC: OPEN
4	REC OUT	Recording amplifier output	5.7V	EF (P - P)
5	REC L2	Recording EQ switch	5.7V	19Ω (ON) / OPEN
6	REC L1	Recording EQ pin	5.7V	B (NPN)
7	EQ CTRL	EQ control	—	See input / output circuit
8	V _{CC}	V _{CC}	12.0V	—
9	RIPPLE FILTER	Ripple filter	12.0V	10kΩ (V _{CC})
10	REC / EE CTRL	REC / EE control	—	See input / output circuit
11	LINE OUT	Line amplifier output	5.7V	EF (P - P)
12	GND	GND	0.0V	—
13	MUTE CTRL	Mute control	—	See input / output circuit
14	LINE IN2	Line input 2	5.6V	120kΩ
15	PB / EE CTRL	PB / EE control	—	See input / output circuit
16	LINE IN1	Line input 1	5.6V	120kΩ
17	INPUT SW CTRL	Input switch control	—	See input / output circuit
18	TUNER IN	Tuner input	5.6V	120kΩ
19	ALC FILTER	For setting the time constant for the ALC filter (attack and recovery times)	PB: 0.0V PB: not fixed	EF (NPN) ~ 100Ω
20	PB LINE IN	Line input for playback	5.6V	120kΩ
21	PB OUT	Playback amplifier output	2.0V	EF (P - P)
22	PB EQ SW	Playback equalizer switch	2.0V	35Ω (ON) / OPEN
23	PB NFB	Playback amplifier feedback	2.0V	B (NPN)
24	HEAD GND	GND for playback amplifier and head switch	0.0V	—

* EF: emitter follower, P-P: push pull, B: base, and C: collector.

All measurements made using the measurement circuit (Fig. 1) with V_{CC} = 12V and quiescent circuit conditions.

All numerical values are standardized values.

● Input / output circuits

EQ CTRL 7

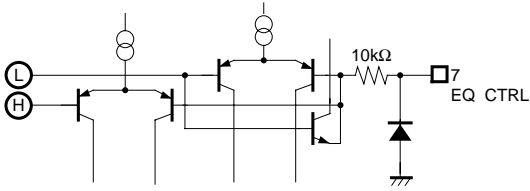

REC / EE CTRL 10

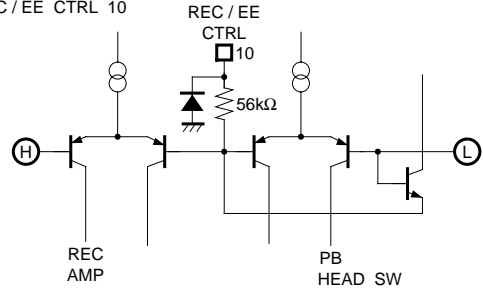

MUTE CTRL 13

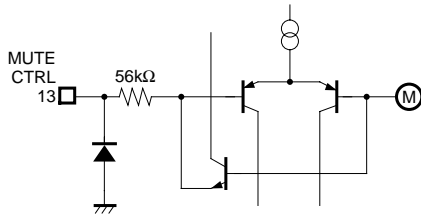

PB / EE CTRL 15

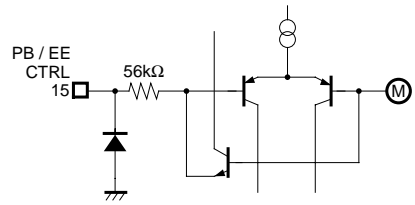

INPUT SW CTRL 17

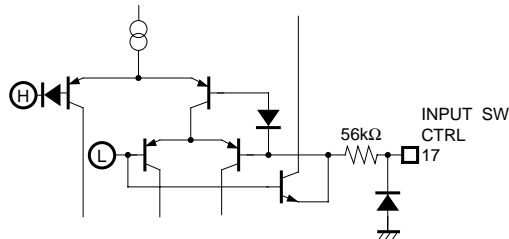

L, M, and H in the above diagrams are 1.7V, 2.5V, and 3.3V respectively.

●Electrical characteristics (unless otherwise noted, Ta = 25°C, Vcc = 12V, and f = 1kHz)

Parameter	Symbol	Min.	Typ.	Max.	Unit	Conditions	Measurement circuit
Quiescent current EE	I _{qEE}	7.4	9.8	13.0	mA	No signal input	Fig.1
Quiescent current PB	I _{qPB}	7.4	9.8	13.0	mA	No signal input	Fig.1
Quiescent current REC	I _{qREC}	6.4	8.4	11.2	mA	No signal input	Fig.1
〈Line amplifier〉							
Voltage gain (PB input)	G _{VCLP}	27.0	28.0	29.0	dB	V _O = -8dBV	Fig.1
Voltage gain (LINE1, LINE2, TU inputs)	G _{VCLT}	19.0	20.0	21.0	dB	V _O = -8dBV	Fig.1
Distortion	THD _{LT}	—	0.1	0.3	%	V _O = -8dBV, R _L = 4.7kΩ*	Fig.1
Maximum output level	V _{OmLT}	7.3	10.5	—	dBV	THD = 1%, R _L = 4.7kΩ*	Fig.1
Output residual noise	V _{NOLT}	—	-81.5	-75	dBV	R _g = 4.7kΩ, DIN AUDIO	Fig.1
ALC level	V _{OA}	-8.2	-7.2	-6.2	dBV	V _{IN} = -25dBV	Fig.1
ALC distortion	THD _A	—	0.1	0.5	%	V _{IN} = -25dBV, R _L = 4.7kΩ*	Fig.1
Mute attenuation ratio	MT	—	-82.0	-72	dB	V _O = 0dBV, DIN AUDIO	Fig.1
〈Recording amplifier〉							
Voltage gain	G _{VCR}	19.0	20.0	21.0	dB	LINE1, LINE2, TUNER→REC OUT	Fig.1
Distortion	THD _R	—	0.13	0.4	%	V _O = -8dBV	Fig.1
Maximum output level	V _{OmR}	7.0	10.0	—	dBV	V _O = -8dBV, R _L = 4.7kΩ*	Fig.1
Openloop gain	G _{VOR}	60	71	—	dB	THD = 1%, R _L = 4.7kΩ*	Fig.1
〈Playback preamplifier〉							
Openloop gain	G _{VOP}	61	68	—	dB	—	Fig.1
Input conversion noise	V _{NINP}	—	-122.5	-114	dBV	R _g = 680Ω, DIN AUDIO	Fig.1
Voltage gain (stand alone, SP mode)	G _{VCP}	35.0	36.0	37.0	dB	PB IN→PB OUT	Fig.1
〈Head switch〉							
PB head switch impedance	R _{PH}	—	11	20	Ω	—	Fig.1
REC head switch impedance	R _{RH}	—	11	20	Ω	—	Fig.1
REC head switch DC withstanding voltage	BV _{RHDC}	—	0	10	μA	E ₃ = ±55V	Fig.1
REC head switch AC withstanding voltage	BV _{RHAC}	80	100	—	V _{P-P}	f = 70kHz, V ₃ ≤ ±1.5V	Fig.2

* Measured at BW = 0.4 to 30kHz.

● Measurement circuits

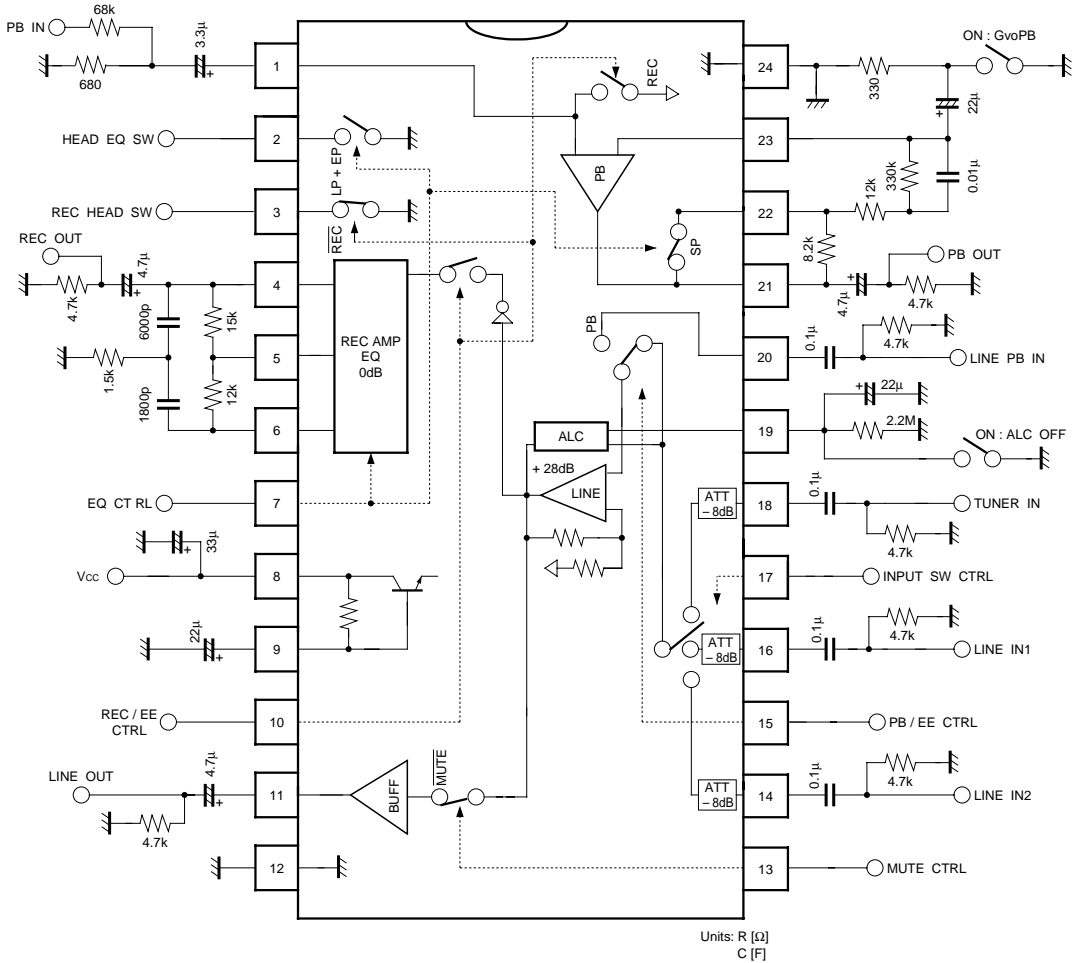

Fig. 1

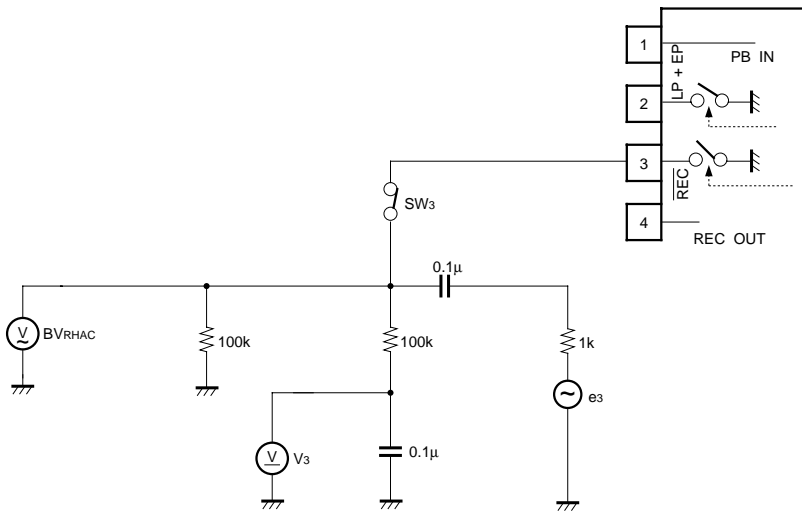

Fig. 2 REC head switch AC withstanding voltage measurement circuit

●Control mode table

(1) REC / EE CTRL, PB / EE CTRL, INPUT SW CTRL

Control pins			Mode	Function			
REC / EE	PB / EE	INPUT SW		PB HSW	REC HSW	LINE SW	REC AMP
L	L	L	TUNER	OFF	ON	TUNER	OFF
L	L	M	LINE2	OFF	ON	LINE2	OFF
L	L	H	LINE1	OFF	ON	LINE1	OFF
L	H	—	PB	OFF	ON	PB	OFF
H	L	L	TU REC	ON	OFF	TUNER	ON
H	L	M	L2 REC	ON	OFF	LINE2	ON
H	L	H	L1 REC	ON	OFF	LINE1	ON
H	H	—	inhibit	—	—	—	—

If REC / EE CTRL is set to "M", the REC pause state is possible (REC head switch: open, REC amplifier: off).

(2) MUTE CTRL

Control pins	Mode	Function
MUTE		LINE SW
H	MUTE	OPEN
L	$\overline{\text{MUTE}}$	CLOSE

(3) EQ CTRL

Control pins	Mode		Function		
	2 MODE	3 MODE	HEAD EQ	PB EQ	REC EQ
L	SP	SP	OFF	CLOSE	CLOSE
M	—	LP	ON	OPEN	CLOSE
H	EP	EP	ON	OPEN	OPEN

●Application example

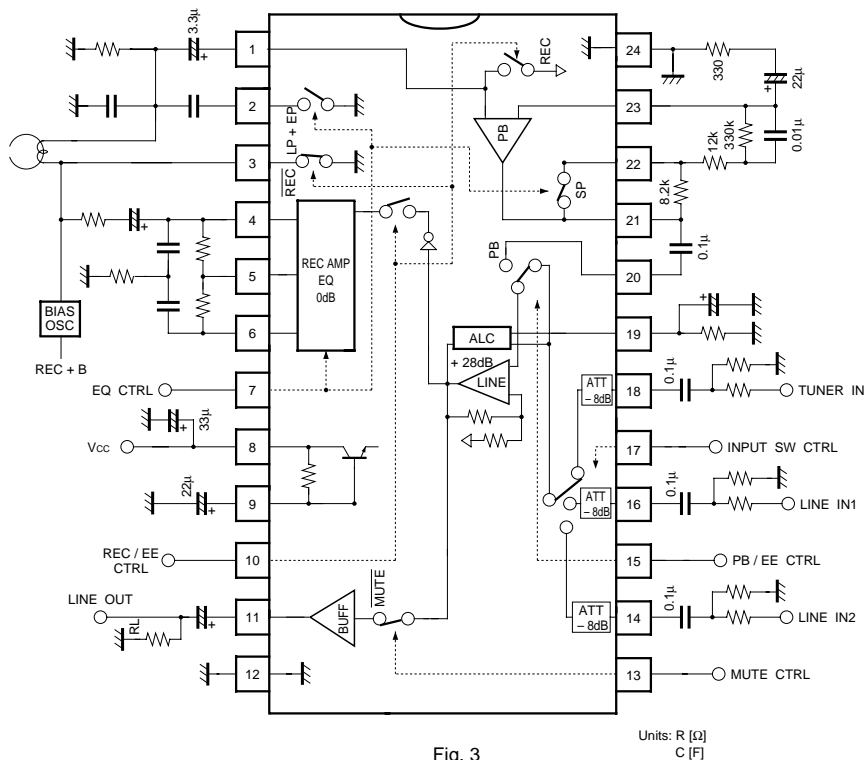

Fig. 3

●Operation notes

(1) Mute signal

Apply the mute signal shown below at power on and off.

If the muting time is short, a “pop” sound will be audible, particularly when the power is switched on.

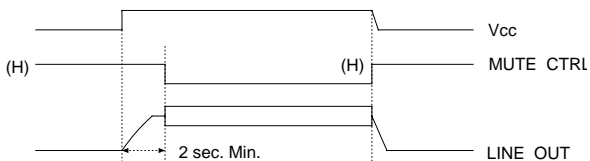

The mute signal must also be applied when switching PB, LINE1, LINE2 and TUNER.

(2) Recording control

Do not switch the PB and REC modes on together. This will cause erroneous operation.

(3) Line output

The line output can drive a load resistance of up to 2k Ω .

Some types of load can result in local oscillation (eg. large capacitive loads that draw large current), so caution is required. In particular, when there is a possibility that the line output will be connected to a shielded cable, or line cable, connect a resistor of about 1k Ω in series with the output so that the capacitive load is not directly coupled to the IC output terminal.

●Electrical characteristic curves

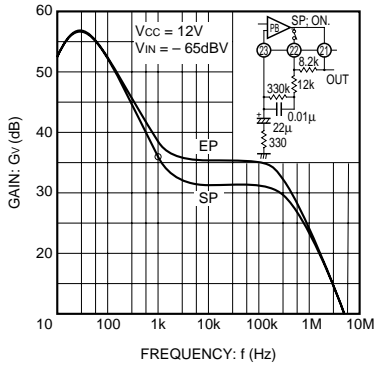

Fig. 4 Gain vs. frequency (PB amplifier)

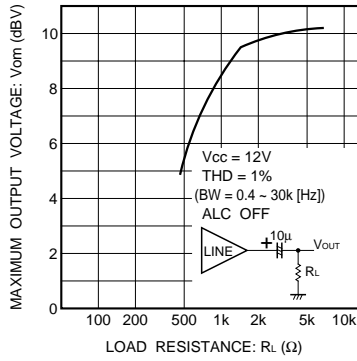

Fig. 5 Line amplifier load drive characteristics

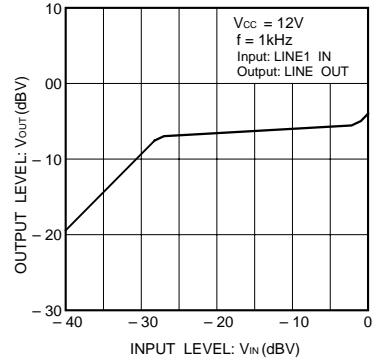

Fig. 6 ALC input / output characteristics

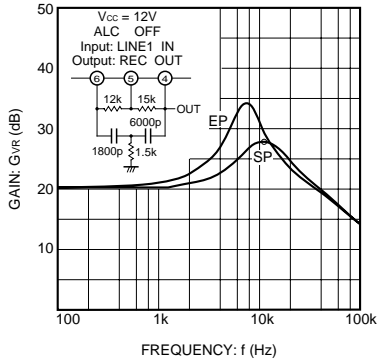

Fig. 7 Gain vs. frequency (REC amplifier)

●External dimensions (Units: mm)

