

DS3486 Quad RS-422, RS-423 Line Receiver

General Description

National's quad RS-422, RS-423 receiver features four independent receivers which comply with EIA Standards for the electrical characteristics of balanced/unbalanced voltage digital interface circuits. Receiver outputs are 74LS compatible, TRI-STATE® structures which are forced to a high impedance state when the appropriate output control pin reaches a logic zero condition. A PNP device buffers each output control pin to assure minimum loading for either logic one or logic zero inputs. In addition, each receiver has internal hysteresis circuitry to improve noise margin and discourage output instability for slowly changing input waveforms.

Features

- Four independent receivers
- TRI-STATE outputs
- Internal hysteresis – 140 mV (typ)
- Fast propagation times – 19 ns (typ)
- TTL compatible outputs
- 5V supply
- Pin compatible and interchangeable with MC3486

Block and Connection Diagrams

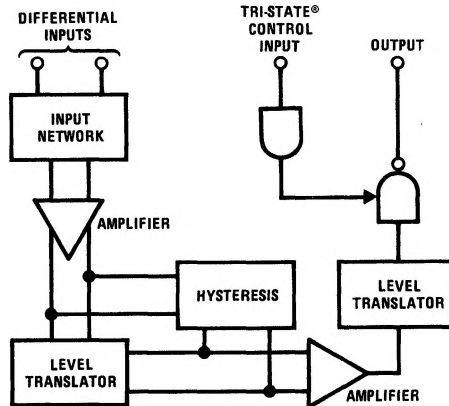

Dual-In-Line Package

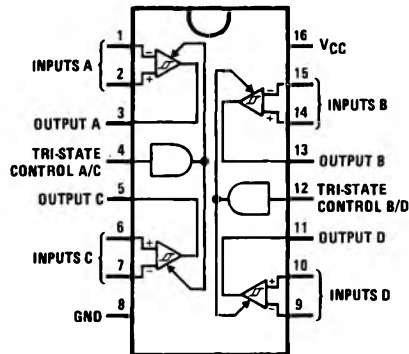

Top View

Order Number DS3486J, DS3486M or DS3486N
See NS Package Number J16A, M16A or N16A

Absolute Maximum Ratings (Note 1)

If Military/Aerospace specified devices are required, please contact the National Semiconductor Sales Office/Distributors for availability and specifications.

Power Supply Voltage, V_{CC}	8V
Input Common-Mode Voltage, V_{ICM}	$\pm 25V$
Input Differential Voltage, V_{ID}	$\pm 25V$
TRI-STATE Control Input Voltage, V_I	8V
Output Sink Current, I_O	50 mA
Storage Temperature, T_{STG}	$-65^{\circ}C$ to $+150^{\circ}C$
Maximum Power Dissipation* at $25^{\circ}C$	
Cavity Package	1433mW
Molded Dip Package	1362 mW
SO Package	1002 mW

*Derate cavity package 9.6 mW/ $^{\circ}C$ above $25^{\circ}C$; derate Dip molded package 10.2 mW/ $^{\circ}C$ above $25^{\circ}C$. Derate SO package 8.01 mW/ $^{\circ}C$ above $25^{\circ}C$.

Operating Conditions

	Min	Max	Units
Power Supply Voltage, V_{CC}	4.75	5.25	V
Operating Temperature, T_A	0	70	$^{\circ}C$
Input Common-Mode Voltage Range, V_{ICR}	-7.0	7.0	V

Electrical Characteristics

(Unless otherwise noted, minimum and maximum limits apply over recommended temperature and power supply voltage ranges. Typical values are for $T_A = 25^{\circ}C$, $V_{CC} = 5V$ and $V_{IC} = 0V$. See Note 2.)

Symbol	Parameter	Conditions	Min	Typ	Max	Units
V_{IH}	Input Voltage—High Logic State (TRI-STATE Control)		2.0			V
V_{IL}	Input Voltage—Low Logic State (TRI-STATE Control)				0.8	V
$V_{TH(D)}$	Differential Input Threshold Voltage	$-7V \leq V_{IC} \leq 7V$, $V_{IH \text{ TRI-STATE}} = 2V$ $I_O = -0.4 \text{ mA}$, $V_{OH} \geq 2.7V$		0.070	0.2	V
		$I_O = 8 \text{ mA}$, $V_{OL} \geq 0.5V$		0.070	-0.2	V
$I_{IB(D)}$	Input Bias Current	$V_{CC} = 0V$ or $5.25V$, Other Inputs at $0V$				
		$V_I = -10V$			-3.25	mA
		$V_I = -3V$			-1.50	mA
		$V_I = 3V$			1.50	mA
		$V_I = 10V$			3.25	mA
	Input Balance	$-7V \leq V_{IC} \leq 7V$, $V_{IH(3C)} = 2V$, (Note 4)				
		V_{OH} $I_O = -0.4 \text{ mA}$, $V_{ID} = 0.4V$	2.7			V
		V_{OL} $I_O = 8 \text{ mA}$, $V_{ID} = -0.4V$			0.5	V
I_{OZ}	Output TRI-STATE Leakage Current	$V_{I(D)} = 3V$, $V_{IL} = 0.8V$, $V_{OL} = 0.5V$			-40	μA
		$V_{I(D)} = -3V$, $V_{IL} = 0.8V$, $V_{OH} = 2.7V$			40	μA
I_{OS}	Output Short-Circuit Current	$V_{I(D)} = 3V$, $V_{IH \text{ TRI-STATE}} = 2V$, $V_O = 0V$, (Note 3)	-15		-100	mA
I_{IL}	Input Current—Low Logic State (TRI-STATE Control)	$V_{IL} = 0.5V$			-100	μA
I_{IH}	Input Current—High Logic State (TRI-STATE Control)	$V_{IH} = 2.7V$			20	μA
		$V_{IH} = 5.25V$			100	μA
V_{IC}	Input Clamp Diode Voltage (TRI-STATE Control)	$I_{IN} = -10 \text{ mA}$			-1.5	V
I_{CC}	Power Supply Current	All Inputs $V_{IL} = 0V$			85	mA

Note 1: "Absolute Maximum Ratings" are those values beyond which the safety of the device cannot be guaranteed. They are not meant to imply that the devices should be operated at these limits. The table of "Electrical Characteristics" provides conditions for actual device operation.

Note 2: All currents into device pins are shown as positive, out of device pins are negative. All voltages referenced to ground unless otherwise noted.

Note 3: Only one output at a time should be shorted.

Note 4: Refer to EIA RS-422/3 for exact conditions.

Switching Characteristics (Unless otherwise noted, $V_{CC} = 5V$ and $T_A = 25^\circ C$.)

Symbol	Parameter	Min	Typ	Max	Units
$t_{PHL(D)}$	Propagation Delay Time—Differential Inputs to Output Output High to Low		19	35	ns
$t_{PLH(D)}$	Output Low to High		19	30	ns
t_{PLZ}	TRI-STATE Control to Output Output Low to TRI-STATE		23	35	ns
t_{PHZ}	Output High to TRI-STATE		25	35	ns
t_{PZH}	Output TRI-STATE to High		18	30	ns
t_{PZL}	Output TRI-STATE to Low		20	30	ns

AC Test Circuits and Switching Time Waveforms

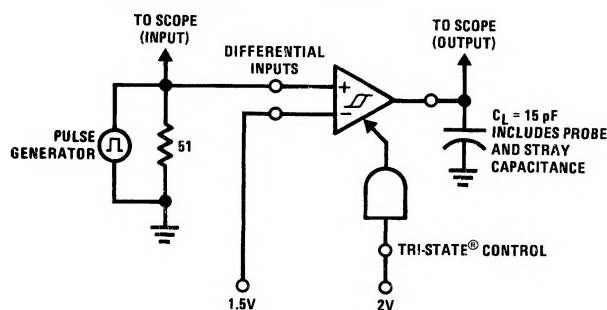

TL/F/5779-3

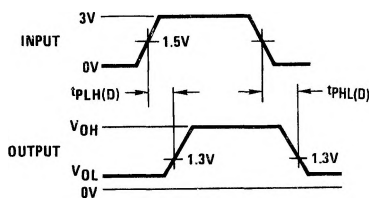

TL/F/5779-4

Input pulse characteristics:

 $t_{TLH} = t_{THL} = 6 \text{ ns}$ (10% to 90%)

PRR = 1 MHz, 50% duty cycle

FIGURE 1. Propagation Delay Differential Input to Output

AC Test and Switching Time Waveforms (Continued)

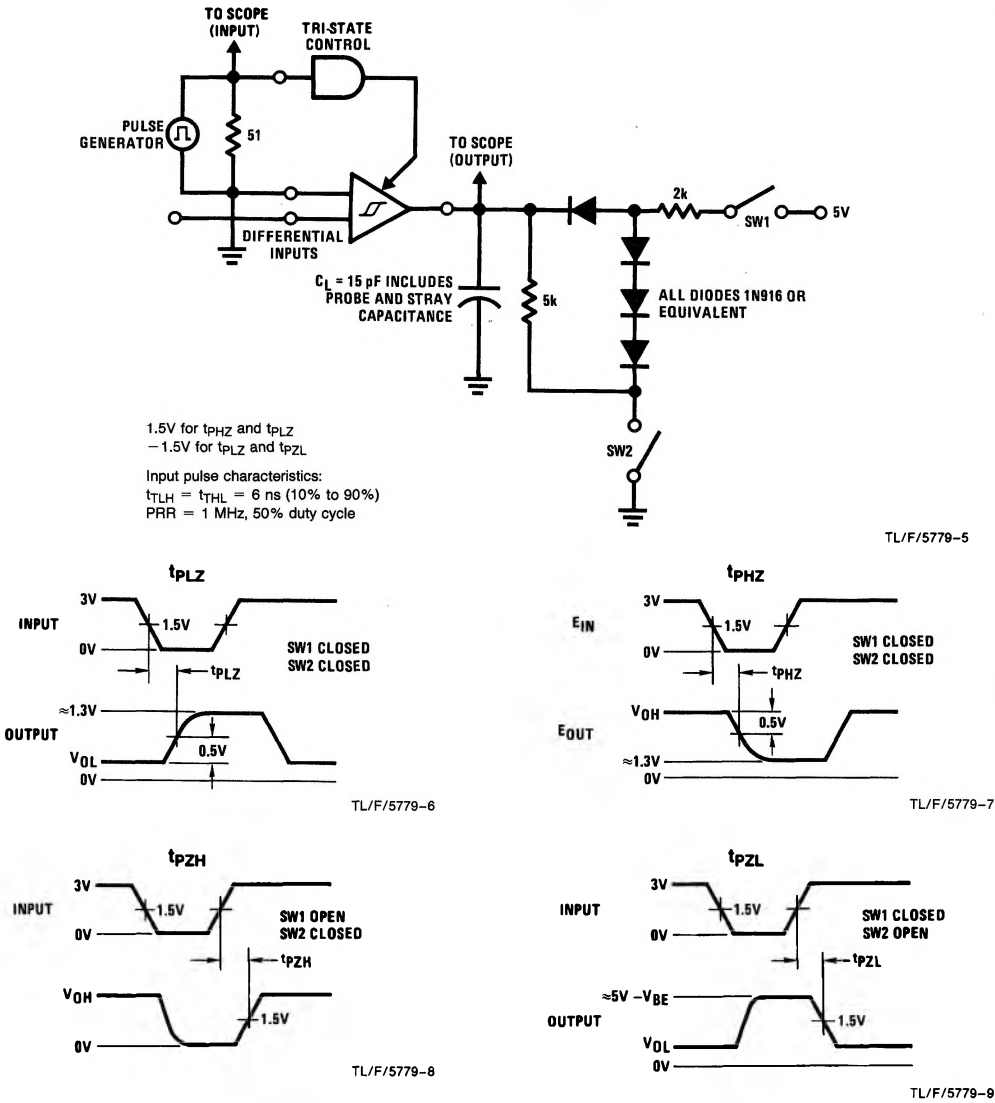

FIGURE 2. Propagation Delay TRI-STATE Control Input to Output