

September 1995

Features

- 3 Micron Radiation Hardened SOS CMOS
- Total Dose 200K RAD (Si)
- SEP Effective LET No Upsets: >100 MEV-cm²/mg
- Single Event Upset (SEU) Immunity < 2 x 10⁻⁹ Errors/Bit-Day (Typ)
- Dose Rate Survivability: >1 x 10¹² RAD (Si)/s
- Dose Rate Upset >10¹⁰ RAD (Si)/s 20ns Pulse
- Cosmic Ray Upset Immunity < 2 x 10⁻⁹ Errors/Bit-Day (Typ)
- Latch-Up Free Under Any Conditions
- Military Temperature Range: -55°C to +125°C
- Significant Power Reduction Compared to LSTTL ICs
- DC Operating Voltage Range: 4.5V to 5.5V
- Input Logic Levels
 - VIL = 30% of VCC Max
 - VIH = 70% of VCC Min
- Input Current Levels I_i ≤ 5μA at VOL, VOH

Description

The Intersil HCS109MS is a Radiation Hardened Dual JK Flip Flop with set and reset. The flip flop changes state with the positive transition of the clock (CP1 or CP2).

The HCS109MS utilizes advanced CMOS/SOS technology to achieve high-speed operation. This device is a member of radiation hardened, high-speed, CMOS/SOS Logic Family.

The HCS109MS is supplied in a 16 lead Ceramic flatpack (K suffix) or a SBDIP Package (D suffix).

Pinouts

16 LEAD CERAMIC DUAL-IN-LINE
METAL SEAL PACKAGE (SBDIP)
MIL-STD-1835 CDIP2-T16, LEAD FINISH C
TOP VIEW

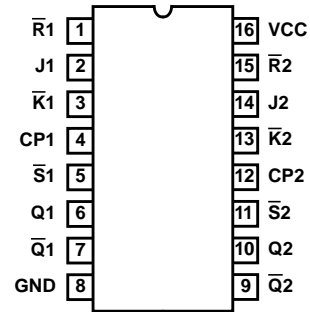

16 LEAD CERAMIC METAL SEAL
FLATPACK PACKAGE (FLATPACK)
MIL-STD-1835 CDFP4-F16, LEAD FINISH C
TOP VIEW

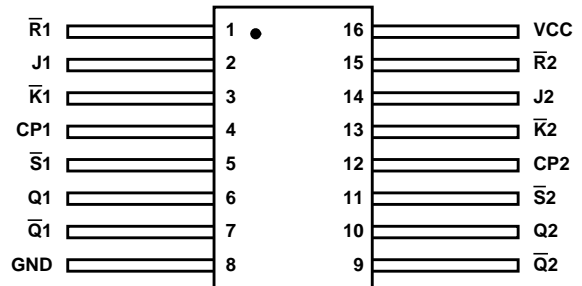

Ordering Information

| PART NUMBER | TEMPERATURE RANGE | SCREENING LEVEL | PACKAGE |
|----------------|-------------------|-----------------------------|--------------------------|
| HCS109DMSR | -55°C to +125°C | Intersil Class S Equivalent | 16 Lead SBDIP |
| HCS109KMSR | -55°C to +125°C | Intersil Class S Equivalent | 16 Lead Ceramic Flatpack |
| HCS109D/Sample | +25°C | Sample | 16 Lead SBDIP |
| HCS109K/Sample | +25°C | Sample | 16 Lead Ceramic Flatpack |
| HCS109HMSR | +25°C | Die | Die |

HCS109MS

Functional Diagram

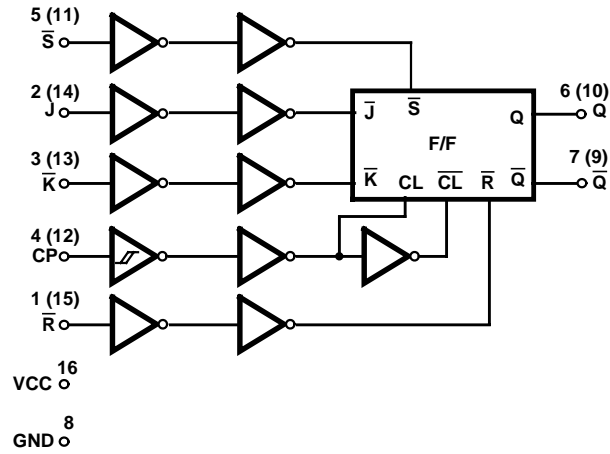

TRUTH TABLE

| INPUTS | | | | | OUTPUTS | |
|-----------|-----------|----|---|-----------|-----------|-----------|
| \bar{S} | \bar{R} | CP | J | \bar{K} | Q | \bar{Q} |
| L | H | X | X | X | H | L |
| H | L | X | X | X | L | H |
| L | L | X | X | X | H* | H* |
| H | H | | L | L | L | H |
| H | H | | H | L | Toggle | |
| H | H | | L | H | No Change | |
| H | H | | H | H | H | L |
| H | H | L | X | X | No Change | |

*Unpredictable and unstable condition if both S and R go high simultaneously

L = Logic Level Low

H = Logic Level High

= Transition from Low to High Level

Specifications HCS109MS

Absolute Maximum Ratings

| | |
|---|--------------------|
| Supply Voltage | -0.5V to +7.0V |
| Input Voltage Range, All Inputs | -0.5V to VCC +0.5V |
| DC Input Current, Any One Input | ±10mA |
| DC Drain Current, Any One Output (All Voltage Reference to the VSS Terminal) | ±25mA |
| Storage Temperature Range (TSTG) | -65°C to +150°C |
| Lead Temperature (Soldering 10sec) | +265°C |
| Junction Temperature (TJ) | +175°C |
| ESD Classification | Class 1 |

Reliability Information

| | | |
|--|---------------|---------------|
| Thermal Resistance | θ_{JA} | θ_{JC} |
| SBDIP Package | 73°C/W | 24°C/W |
| Ceramic Flatpack Package | 114°C/W | 29°C/W |
| Maximum Package Power Dissipation at +125°C Ambient | | |
| SBDIP Package | 0.68W | |
| Ceramic Flatpack Package | 0.44W | |
| If device power exceeds package dissipation capability, provide heat sinking or derate linearly at the following rate: | | |
| SBDIP Package | 13.7mW/°C | |
| Ceramic Flatpack Package | 8.8mW/°C | |

CAUTION: As with all semiconductors, stress listed under "Absolute Maximum Ratings" may be applied to devices (one at a time) without resulting in permanent damage. This is a stress rating only. Exposure to absolute maximum rating conditions for extended periods may affect device reliability. The conditions listed under "Electrical Performance Characteristics" are the only conditions recommended for satisfactory device operation.

Operating Conditions

| | | | |
|---|-----------------|--------------------------|--------------------|
| Supply Voltage | +4.5V to +5.5V | Input Low Voltage (VIL) | 0.0V to 30% of VCC |
| Input Rise and Fall Times at 4.5 VCC (TR, TF) | .500ns Max | Input High Voltage (VIH) | 70% of VCC to VCC |
| Operating Temperature Range (TA) | -55°C to +125°C | | |

TABLE 1. DC ELECTRICAL PERFORMANCE CHARACTERISTICS

| PARAMETER | SYMBOL | (NOTE 1) CONDITIONS | GROUP A SUB- GROUPS | TEMPERATURE | LIMITS | | UNITS |
|-----------------------------------|--------|---|---------------------------|----------------------|-------------|------|-------|
| | | | | | MIN | MAX | |
| Quiescent Current | ICC | VCC = 5.5V, VIN = VCC or GND | 1 | +25°C | - | 20 | µA |
| | | | 2, 3 | +125°C, -55°C | - | 400 | µA |
| Output Current (Sink) | IOL | VCC = 4.5V, VIH = 4.5V, VOUT = 0.4V, VIL = 0V | 1 | +25°C | 4.8 | - | mA |
| | | | 2, 3 | +125°C, -55°C | 4.0 | - | mA |
| Output Current (Source) | IOH | VCC = 4.5V, VIH = 4.5V, VOUT = VCC -0.4V, VIL = 0V | 1 | +25°C | -4.8 | - | mA |
| | | | 2, 3 | +125°C, -55°C | -4.0 | - | mA |
| Output Voltage Low | VOL | VCC = 4.5V, VIH = 3.15V, IOL = 50µA, VIL = 1.35V | 1, 2, 3 | +25°C, +125°C, -55°C | - | 0.1 | V |
| | | VCC = 5.5V, VIH = 3.85V, IOL = 50µA, VIL = 1.65V | 1, 2, 3 | +25°C, +125°C, -55°C | - | 0.1 | V |
| Output Voltage High | VOH | VCC = 4.5V, VIH = 3.15V, IOH = -50µA, VIL = 1.35V | 1, 2, 3 | +25°C, +125°C, -55°C | VCC -0.1 | - | V |
| | | VCC = 5.5V, VIH = 3.85V, IOH = -50µA, VIL = 1.65V | 1, 2, 3 | +25°C, +125°C, -55°C | VCC -0.1 | - | V |
| Input Leakage Current | IIN | VCC = 5.5V, VIN = VCC or GND | 1 | +25°C | - | ±0.5 | µA |
| | | | 2, 3 | +125°C, -55°C | - | ±5.0 | µA |
| Noise Immunity Functional Test | FN | VCC = 4.5V, VIH = 0.70(VCC), VIL = 0.30(VCC) (Note 2) | 7, 8A, 8B | +25°C, +125°C, -55°C | - | - | - |

NOTES:

1. All voltages reference to device GND.
2. For functional tests, VO ≥ 4.0V is recognized as a logic "1", and VO ≤ 0.5V is recognized as a logic "0".

Specifications HCS109MS

TABLE 2. AC ELECTRICAL PERFORMANCE CHARACTERISTICS

| PARAMETER | SYMBOL | (NOTES 1, 2) CONDITIONS | GROUP A SUBGROUPS | TEMPERATURE | LIMITS | | UNITS |
|------------------------|--------|----------------------------|----------------------|---------------|--------|-----|-------|
| | | | | | MIN | MAX | |
| CP to Q, \bar{Q} | TPLH | VCC = 4.5V | 9 | +25°C | 2 | 26 | ns |
| | | VCC = 4.5V | 10, 11 | +125°C, -55°C | 2 | 30 | ns |
| | TPHL | VCC = 4.5V | 9 | +25°C | 2 | 30 | ns |
| | | VCC = 4.5V | 10, 11 | +125°C, -55°C | 2 | 35 | ns |
| \bar{S} to Q | TPLH | VCC = 4.5V | 9 | +25°C | 2 | 19 | ns |
| | | VCC = 4.5V | 10, 11 | +125°C, -55°C | 2 | 23 | ns |
| \bar{S} to \bar{Q} | TPHL | VCC = 4.5V | 9 | +25°C | 2 | 31 | ns |
| | | VCC = 4.5V | 10, 11 | +125°C, -55°C | 2 | 33 | ns |
| \bar{R} to Q | TPHL | VCC = 4.5V | 9 | +25°C | 2 | 31 | ns |
| | | VCC = 4.5V | 10, 11 | +125°C, -55°C | 2 | 33 | ns |
| \bar{R} to \bar{Q} | TPLH | VCC = 4.5V | 9 | +25°C | 2 | 31 | ns |
| | | VCC = 4.5V | 10, 11 | +125°C, -55°C | 2 | 33 | ns |

NOTES:

1. All voltages referenced to device GND.
2. AC measurements assume $R_L = 500\Omega$, $C_L = 50\text{pF}$, Input $T_R = T_F = 3\text{ns}$, $V_{IL} = \text{GND}$, $V_{IH} = \text{VCC}$.

TABLE 3. ELECTRICAL PERFORMANCE CHARACTERISTICS

| PARAMETER | SYMBOL | CONDITIONS | NOTES | TEMPERATURE | LIMITS | | UNITS |
|--|--------------|----------------------|-------|---------------|--------|-----|-------|
| | | | | | MIN | MAX | |
| Capacitance Power Dissipation | CPD | VCC = 5.0V, f = 1MHz | 1 | +25°C | - | 41 | pF |
| | | | 1 | +125°C, -55°C | - | 56 | pF |
| Input Capacitance | CIN | VCC = 5.0V, f = 1MHz | 1 | +25°C | - | 10 | pF |
| | | | 1 | +125°C, -55°C | - | 10 | pF |
| Output Transition Time | TTHL TTLH | VCC = 4.5V | 1 | +25°C | - | 15 | ns |
| | | | 1 | +125°C, -55°C | - | 22 | ns |
| Max Operating Frequency | FMAX | VCC = 4.5V | 1 | +25°C | - | 30 | MHz |
| | | | 1 | +125°C, -55°C | - | 20 | MHz |
| Setup Time JK to CP | TSU | VCC = 4.5V | 1 | +25°C | 18 | - | ns |
| | | | 1 | +125°C, -55°C | 27 | - | ns |
| Hold Time JK to CP | TH | VCC = 4.5V | 1 | +25°C | 3 | - | ns |
| | | | 1 | +125°C, -55°C | 3 | - | ns |
| Removal Time \bar{R} , \bar{S} to CP | TREM | VCC = 4.5V | 1 | +25°C | 18 | - | ns |
| | | | 1 | +125°C, -55°C | 27 | - | ns |
| Pulse Width CP | TW | VCC = 4.5V | 1 | +25°C | 18 | - | ns |
| | | | 1 | +125°C, -55°C | 27 | - | ns |
| Pulse Width \bar{R} , \bar{S} | TW | VCC = 4.5V | 1 | +25°C | 18 | - | ns |
| | | | 1 | +125°C, -55°C | 27 | - | ns |

NOTE:

1. The parameters listed in Table 3 are controlled via design or process parameters. Min and Max Limits are guaranteed but not directly tested. These parameters are characterized upon initial design release and upon design changes which affect these characteristics.

Specifications HCS109MS

TABLE 4. DC POST RADIATION ELECTRICAL PERFORMANCE CHARACTERISTICS

| PARAMETER | SYMBOL | (NOTES 1, 2) CONDITIONS | TEMPERATURE | 200K RAD LIMITS | | UNITS |
|--------------------------------|--------|---|-------------|--------------------|-----|-------|
| | | | | MIN | MAX | |
| Quiescent Current | ICC | VCC = 5.5V, VIN = VCC or GND | +25°C | - | 0.4 | mA |
| Output Current (Sink) | IOL | VCC = 4.5V, VIN = VCC or GND, VOUT = 0.4V | +25°C | 4.0 | - | mA |
| Output Current (Source) | IOH | VCC = 4.5V, VIN = VCC or GND, VOUT = VCC -0.4V | +25°C | -4.0 | - | mA |
| Output Voltage Low | VOL | VCC = 4.5V and 5.5V, VIH = 0.70(VCC), VIL = 0.30(VCC), IOL = 50µA | +25°C | - | 0.1 | V |
| Output Voltage High | VOH | VCC = 4.5V and 5.5V, VIH = 0.70(VCC), VIL = 0.30(VCC), IOH = -50µA | +25°C | VCC -0.1 | - | V |
| Input Leakage Current | IIN | VCC = 5.5V, VIN = VCC or GND | +25°C | - | ±5 | µA |
| Noise Immunity Functional Test | FN | VCC = 4.5V, VIH = 0.70(VCC), VIL = 0.30(VCC), (Note 3) | +25°C | - | - | - |
| CP to Q, \bar{Q} | TPLH | VCC = 4.5V | +25°C | 2 | 30 | ns |
| | TPHL | VCC = 4.5V | +25°C | 2 | 35 | ns |
| \bar{S} to Q | TPLH | VCC = 4.5V | +25°C | 2 | 23 | ns |
| \bar{S} to \bar{Q} | TPHL | VCC = 4.5V | +25°C | 2 | 33 | ns |
| \bar{R} to Q | TPHL | VCC = 4.5V | +25°C | 2 | 33 | ns |
| \bar{R} to \bar{Q} | TPLH | VCC = 4.5V | +25°C | 2 | 33 | ns |

NOTES:

1. All voltages referenced to device GND.
2. AC measurements assume RL = 500Ω, CL = 50pF, Input TR = TF = 3ns, VIL = GND, VIH = VCC.
3. For functional tests, VO ≥ 4.0V is recognized as a logic "1", and VO ≤ 0.5V is recognized as a logic "0".

TABLE 5. BURN-IN AND OPERATING LIFE TEST, DELTA PARAMETERS (+25°C)

| PARAMETER | GROUP B SUBGROUP | DELTA LIMIT |
|-----------|---------------------|----------------|
| ICC | 5 | 6µA |
| IOL/IOH | 5 | -15% of 0 Hour |

Specifications HCS109MS

TABLE 6. APPLICABLE SUBGROUPS

| CONFORMANCE GROUPS | | METHOD | GROUP A SUBGROUPS | READ AND RECORD |
|--------------------------------|--------------|-------------|---------------------------------------|--|
| Initial Test (Preburn-In) | | 100%/5004 | 1, 7, 9 | ICC, IOL/H |
| Interim Test I (Postburn-In) | | 100%/5004 | 1, 7, 9 | ICC, IOL/H |
| Interim Test II (Postburn-In) | | 100%/5004 | 1, 7, 9 | ICC, IOL/H |
| PDA | | 100%/5004 | 1, 7, 9, Deltas | |
| Interim Test III (Postburn-In) | | 100%/5004 | 1, 7, 9 | ICC, IOL/H |
| PDA | | 100%/5004 | 1, 7, 9, Deltas | |
| Final Test | | 100%/5004 | 2, 3, 8A, 8B, 10, 11 | |
| Group A (Note 1) | | Sample/5005 | 1, 2, 3, 7, 8A, 8B, 9, 10, 11 | |
| Group B | Subgroup B-5 | Sample/5005 | 1, 2, 3, 7, 8A, 8B, 9, 10, 11, Deltas | Subgroups 1, 2, 3, 9, 10, 11, (Note 2) |
| | Subgroup B-6 | Sample/5005 | 1, 7, 9 | |
| Group D | | Sample/5005 | 1, 7, 9 | |

NOTES:

1. Alternate group A testing in accordance with method 5005 of MIL-STD-883 may be exercised.
2. Table 5 parameters only.

TABLE 7. TOTAL DOSE IRRADIATION

| CONFORMANCE GROUPS | METHOD | TEST | | READ AND RECORD | |
|--------------------|--------|---------|----------|-----------------|------------------|
| | | PRE RAD | POST RAD | PRE RAD | POST RAD |
| Group E Subgroup 2 | 5005 | 1, 7, 9 | Table 4 | 1, 9 | Table 4 (Note 1) |

NOTE:

1. Except FN test which will be performed 100% Go/No-Go.

TABLE 8. STATIC AND DYNAMIC BURN-IN TEST CONNECTIONS

| OPEN | GROUND | 1/2 VCC = 3V ± 0.5V | VCC = 6V ± 0.5V | OSCILLATOR | |
|---|-------------------|---------------------|------------------|------------|--------------|
| | | | | 50kHz | 25kHz |
| STATIC BURN-IN I TEST CONNECTIONS (Note 1) | | | | | |
| 6, 7, 9, 10 | 1 - 5, 8, 11 - 15 | - | 16 | - | - |
| STATIC BURN-IN II TEST CONNECTIONS (Note 1) | | | | | |
| 6, 7, 9, 10 | 8 | - | 1 - 5, 11 - 16 | - | - |
| DYNAMIC BURN-IN TEST CONNECTIONS (Note 2) | | | | | |
| - | 8 | 6, 7, 9, 10 | 1, 5, 11, 15, 16 | 4, 12 | 2, 3, 13, 14 |

NOTES:

1. Each pin except VCC and GND will have a resistor of 10KΩ ± 5% for static burn-in
2. Each pin except VCC and GND will have a resistor of 1KΩ ± 5% for dynamic burn-in

TABLE 9. IRRADIATION TEST CONNECTIONS

| OPEN | GROUND | VCC = 5V ± 0.5V |
|-------------|--------|-----------------|
| 6, 7, 9, 10 | 8 | 1 - 5, 11 - 16 |

NOTE: Each pin except VCC and GND will have a resistor of 47KΩ ± 5% for irradiation testing. Group E, Subgroup 2, sample size is 4 dice/wafer 0 failures.

Intersil Space Level Product Flow - 'MS'

| | |
|--|--|
| Wafer Lot Acceptance (All Lots) Method 5007 (Includes SEM) | 100% Interim Electrical Test 1 (T1) |
| GAMMA Radiation Verification (Each Wafer) Method 1019, 4 Samples/Wafer, 0 Rejects | 100% Delta Calculation (T0-T1) |
| 100% Nondestructive Bond Pull, Method 2023 | 100% Static Burn-In 2, Condition A or B, 24 hrs. min., +125°C min., Method 1015 |
| Sample - Wire Bond Pull Monitor, Method 2011 | 100% Interim Electrical Test 2 (T2) |
| Sample - Die Shear Monitor, Method 2019 or 2027 | 100% Delta Calculation (T0-T2) |
| 100% Internal Visual Inspection, Method 2010, Condition A | 100% PDA 1, Method 5004 (Notes 1 and 2) |
| 100% Temperature Cycle, Method 1010, Condition C, 10 Cycles | 100% Dynamic Burn-In, Condition D, 240 hrs., +125°C or Equivalent, Method 1015 |
| 100% Constant Acceleration, Method 2001, Condition per Method 5004 | 100% Interim Electrical Test 3 (T3) |
| 100% PIND, Method 2020, Condition A | 100% Delta Calculation (T0-T3) |
| 100% External Visual | 100% PDA 2, Method 5004 (Note 2) |
| 100% Serialization | 100% Final Electrical Test |
| 100% Initial Electrical Test (T0) | 100% Fine/Gross Leak, Method 1014 |
| 100% Static Burn-In 1, Condition A or B, 24 hrs. min., +125°C min., Method 1015 | 100% Radiographic, Method 2012 (Note 3) |
| | 100% External Visual, Method 2009 |
| | Sample - Group A, Method 5005 (Note 4) |
| | 100% Data Package Generation (Note 5) |

NOTES:

1. Failures from Interim electrical test 1 and 2 are combined for determining PDA 1.
2. Failures from subgroup 1, 7, 9 and deltas are used for calculating PDA. The maximum allowable PDA = 5% with no more than 3% of the failures from subgroup 7.
3. Radiographic (X-Ray) inspection may be performed at any point after serialization as allowed by Method 5004.
4. Alternate Group A testing may be performed as allowed by MIL-STD-883, Method 5005.
5. Data Package Contents:
 - Cover Sheet (Intersil Name and/or Logo, P.O. Number, Customer Part Number, Lot Date Code, Intersil Part Number, Lot Number, Quantity).
 - Wafer Lot Acceptance Report (Method 5007). Includes reproductions of SEM photos with percent of step coverage.
 - GAMMA Radiation Report. Contains Cover page, disposition, Rad Dose, Lot Number, Test Package used, Specification Numbers, Test equipment, etc. Radiation Read and Record data on file at Intersil.
 - X-Ray report and film. Includes penetrometer measurements.
 - Screening, Electrical, and Group A attributes (Screening attributes begin after package seal).
 - Lot Serial Number Sheet (Good units serial number and lot number).
 - Variables Data (All Delta operations). Data is identified by serial number. Data header includes lot number and date of test.
 - The Certificate of Conformance is a part of the shipping invoice and is not part of the Data Book. The Certificate of Conformance is signed by an authorized Quality Representative.

All Intersil semiconductor products are manufactured, assembled and tested under **ISO9000** quality systems certification.

Intersil products are sold by description only. Intersil Corporation reserves the right to make changes in circuit design and/or specifications at any time without notice. Accordingly, the reader is cautioned to verify that data sheets are current before placing orders. Information furnished by Intersil is believed to be accurate and reliable. However, no responsibility is assumed by Intersil or its subsidiaries for its use; nor for any infringements of patents or other rights of third parties which may result from its use. No license is granted by implication or otherwise under any patent or patent rights of Intersil or its subsidiaries.

For information regarding Intersil Corporation and its products, see web site <http://www.intersil.com>

Sales Office Headquarters

NORTH AMERICA

Intersil Corporation
P. O. Box 883, Mail Stop 53-204
Melbourne, FL 32902
TEL: (321) 724-7000
FAX: (321) 724-7240

EUROPE

Intersil SA
Mercure Center
100, Rue de la Fusee
1130 Brussels, Belgium
TEL: (32) 2.724.2111
FAX: (32) 2.724.22.05

ASIA

Intersil (Taiwan) Ltd.
Taiwan Limited
7F-6, No. 101 Fu Hsing North Road
Taipei, Taiwan
Republic of China
TEL: (886) 2 2716 9310
FAX: (886) 2 2715 3029

AC Timing Diagrams

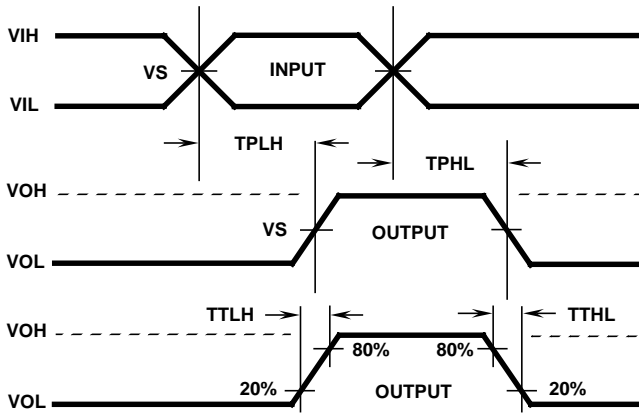

AC VOLTAGE LEVELS

| PARAMETER | HCS | UNITS |
|-----------|------|-------|
| VCC | 4.50 | V |
| V_{IH} | 4.50 | V |
| V_S | 2.25 | V |
| V_{IL} | 0 | V |
| GND | 0 | V |

AC Load Circuit

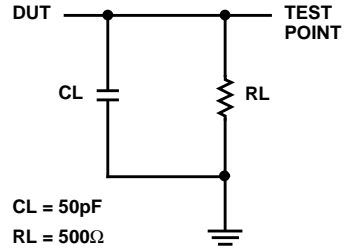

Pulse Width, Setup, Hold Timing Diagram Positive Edge Trigger

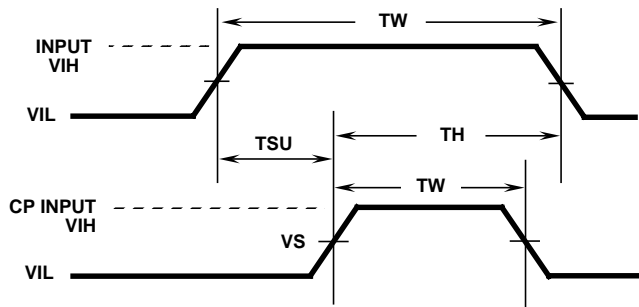

TH = Hold Time
 TSU = Setup Time
 TW = Pulse Width

PULSE WIDTH, SETUP, HOLD VOLTAGE LEVELS

| PARAMETER | HCS | UNITS |
|-----------|------|-------|
| VCC | 4.50 | V |
| V_{IH} | 4.50 | V |
| V_S | 2.25 | V |
| V_{IL} | 0 | V |
| GND | 0 | V |

Load Circuit

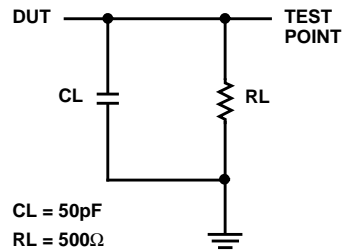

HCS109MS

Die Characteristics

DIE DIMENSIONS:

89 x 88 mils
2.25 x 2.24mm

METALLIZATION:

Type: AlSi
Metal Thickness: $11\text{k}\text{\AA} \pm 1\text{k}\text{\AA}$

GLASSIVATION:

Type: SiO_2
Thickness: $13\text{k}\text{\AA} \pm 2.6\text{k}\text{\AA}$

WORST CASE CURRENT DENSITY:

$<2.0 \times 10^5 \text{A/cm}^2$

BOND PAD SIZE:

$100\mu\text{m} \times 100\mu\text{m}$
4 x 4 mils

Metallization Mask Layout

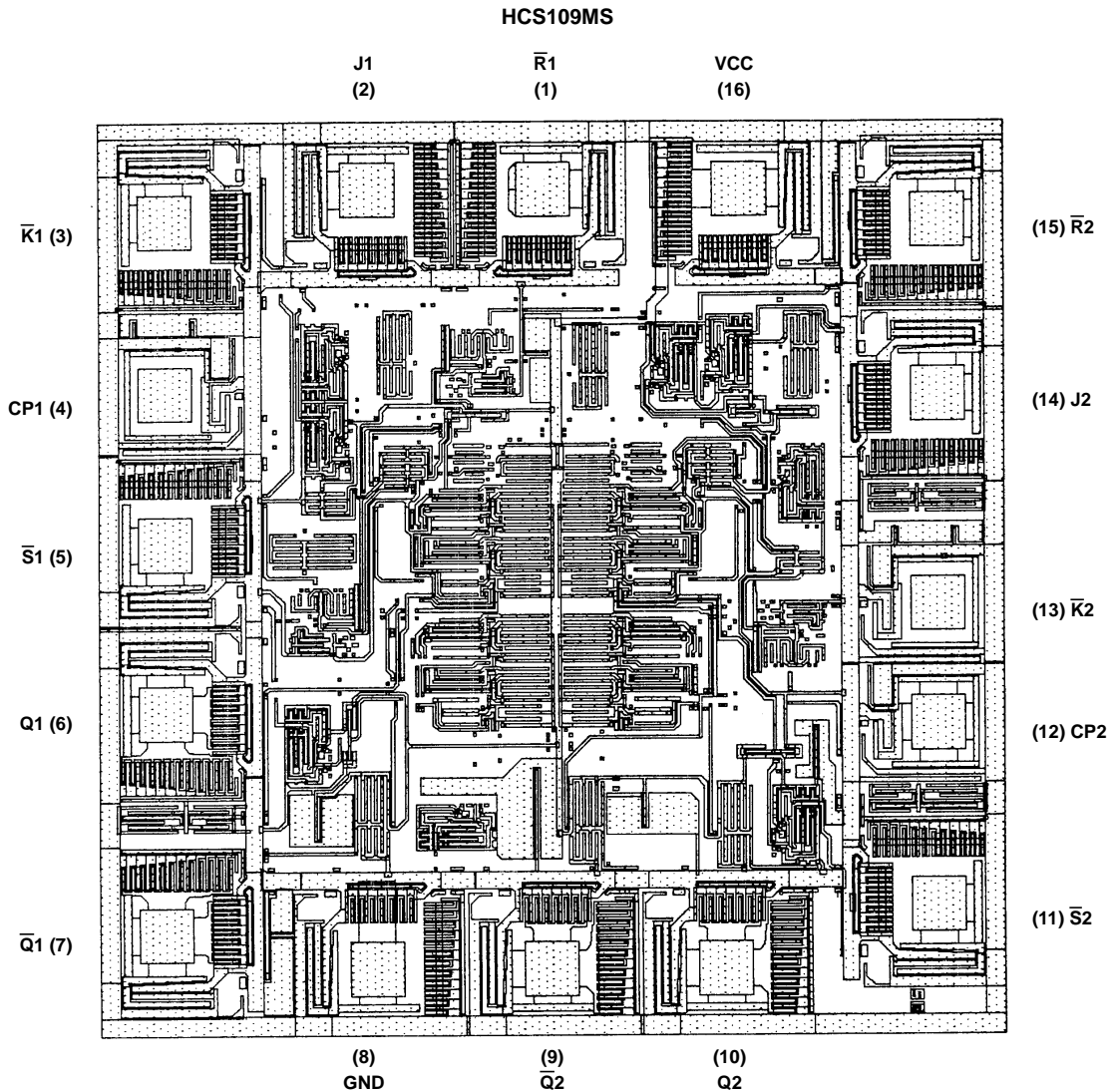

NOTE: The die diagram is a generic plot from a similar HCS device. It is intended to indicate approximate die size and bond pad location. The mask series for the HCS109 is TA14340A.