

## GENERAL PURPOSE CLOCK GENERATOR

### 1.0 General description.

HTC555 is a general-purpose clock generator. It requires no external components and provides wide range of clock frequencies. It's very easy to use and provides general clock solution in wide range of applications. It is very simple to design and operate. Output frequency is determined by value of D[0:4]. Refer to Output frequency table.

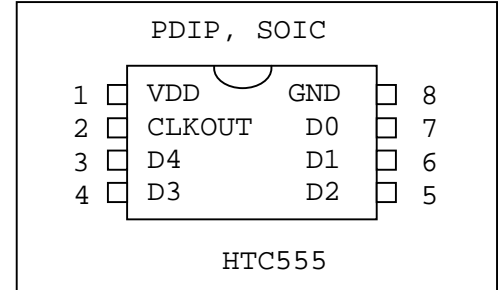

### Features

- Single chip solution.
- Replaces clock generator.
- Has one percent frequency accuracy at room temperature.
- Has ten percent frequency accuracy over temperature range and VDD voltage range.
- Requires no external components for operation.

### 2.0 Application.

Typical connection diagram.

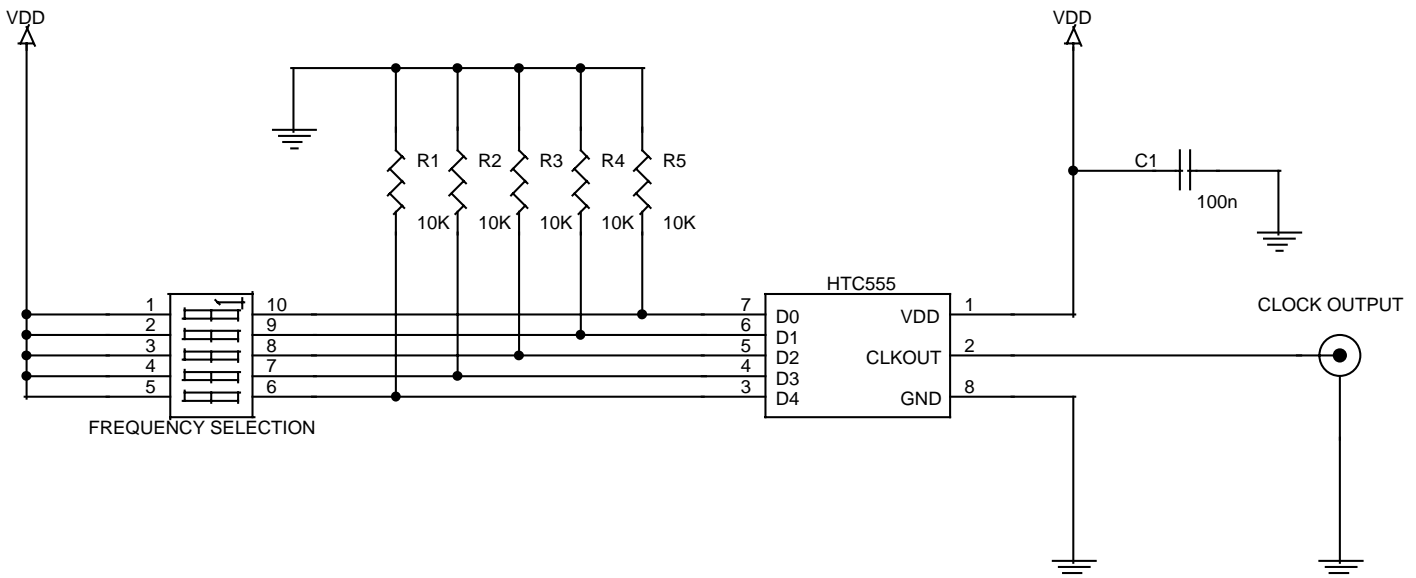

With this application we can generate thirty-two different output frequencies. See output frequency selection table for dip switch settings. Setting “Frequency Selection” dip switch sets frequency. HTC555 reads input switch value constantly and output frequency is set per new value if D[0:4] inputs are changed. Time that takes to change output frequency to new value is relative to period of previous frequency setting. For example if HTC555 was generating 10000Hz clock and we changed it to 25000Hz clock, then output frequency will change in 1/10000Hz or 100uS. In order to avoid output glitches, HTC555 changes its output frequency after finishing current output period. R1-R5 value could be in a range of 1K to 10K in this application. Please note that if only one frequency is needed then we can connect D [0:4] pins directly to ground or VDD. C1 is used, as de-coupling capacitor and could be omitted.

### 3.0 Pin out description.

Abbreviations used: O - output, I - input, P - power.

Pin number	Name	I / O	Description	Notes
1	VDD	P	Power	+2.5V to + 5.5V.
2	CLKOUT	O	Clock Output	Output frequency.
3	D4	I	Frequency selector input.	Tie to GND or VDD.
4	D3	I	Frequency selector input.	Tie to GND or VDD.
5	D2	I	Frequency selector input.	Tie to GND or VDD.
6	D1	I	Frequency selector input.	Tie to GND or VDD.
7	D0	I	Frequency selector input.	Tie to GND or VDD.
8	GND	P	Ground	Connect to ground.

### Output Frequency Selection.

Abbreviations used: 0 – connection to GND, 1 – connection to VDD.

D4	D3	D2	D1	D0	CLK ( output frequency)
0	0	0	0	0	1Hz
0	0	0	0	1	10 Hz
0	0	0	1	0	20 Hz
0	0	0	1	1	30 Hz
0	0	1	0	0	40 Hz
0	0	1	0	1	50 Hz
0	0	1	1	0	60 Hz
0	0	1	1	1	70 Hz
0	1	0	0	0	80 Hz
0	1	0	0	1	90 Hz
0	1	0	1	0	100 Hz
0	1	0	1	1	200 Hz
0	1	1	0	0	300 Hz
0	1	1	0	1	400 Hz
0	1	1	1	0	500 Hz

0	1	1	1	1	600 Hz
1	0	0	0	0	700 Hz
1	0	0	0	1	800 Hz
1	0	0	1	0	900 Hz
1	0	0	1	1	1000 Hz
1	0	1	0	0	2000 Hz
1	0	1	0	1	3000 Hz
1	0	1	1	0	4000 Hz
1	0	1	1	1	5000 Hz
1	1	0	0	0	6000 Hz
1	1	0	0	1	7000 Hz
1	1	0	1	0	8000 Hz
1	1	0	1	1	9000 Hz
1	1	1	0	0	10000 Hz
1	1	1	0	1	25000 Hz
1	1	1	1	0	50000 Hz
1	1	1	1	1	100000 Hz

#### 4.0 Electrical characteristics.

Voltage on VDD pin in respect to GND	+2.5 to +5.5V
Current consumption with no load attached	3 mA <sup>1</sup>
CLKOUT output low voltage (5mA load)	0.4V <sup>1</sup>
CLKOUT output low voltage (25mA load)	0.75V <sup>1</sup>
CLKOUT output high voltage (5mA source)	VDD-0.7V <sup>1</sup>
CLKOUT output source current max	25mA <sup>1</sup>
CLKOUT output sink current max	25mA <sup>1</sup>

#### NOTES:

1. Those values are characterized but not tested.

#### 5.0 Ordering information.

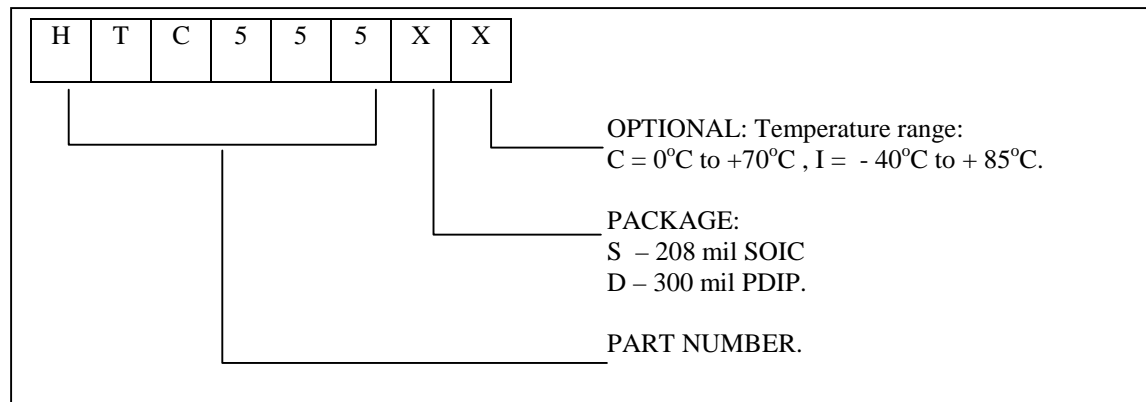

## 6.0 Mechanical information.

### 8-Lead Plastic Dual In-line (P) – 300 mil (PDIP)

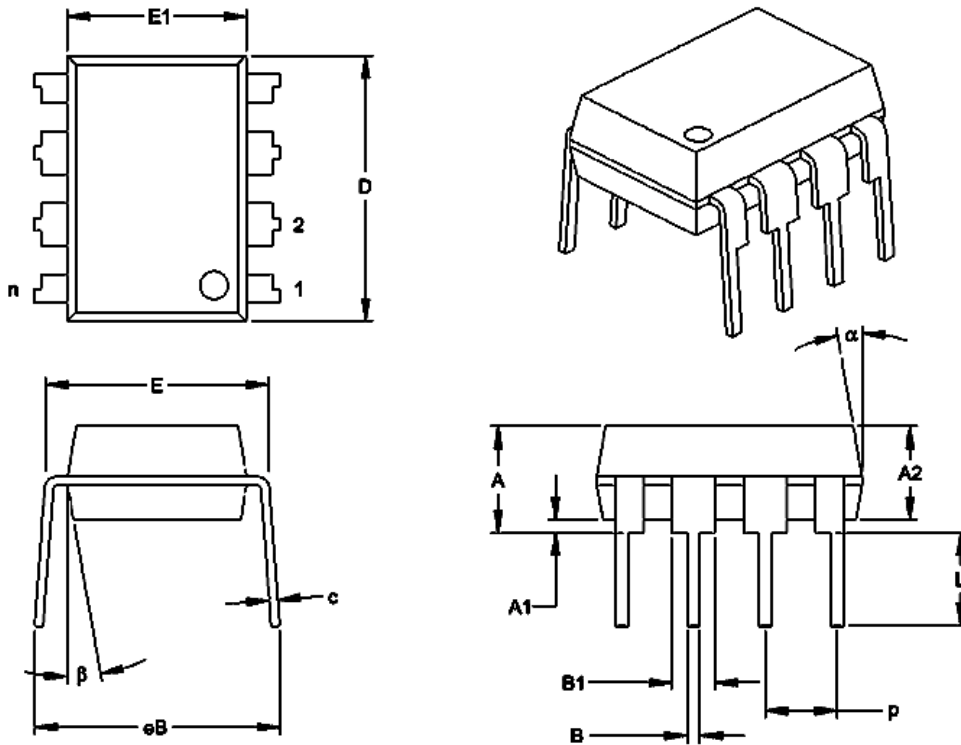

Dimension Limits	Units	INCHES*			MILLIMETERS		
		MIN	NOM	MAX	MIN	NOM	MAX
Number of Pins	n		8			8	
Pitch	p		.100			2.54	
Top to Seating Plane	A	.140	.155	.170	3.56	3.94	4.32
Molded Package Thickness	A2	.115	.130	.145	2.92	3.30	3.68
Base to Seating Plane	A1	.015			0.38		
Shoulder to Shoulder Width	E	.300	.313	.325	7.62	7.94	8.26
Molded Package Width	E1	.240	.250	.260	6.10	6.35	6.60
Overall Length	D	.360	.373	.385	9.14	9.46	9.78
Tip to Seating Plane	L	.125	.130	.135	3.18	3.30	3.43
Lead Thickness	c	.008	.012	.015	0.20	0.29	0.38
Upper Lead Width	B1	.045	.058	.070	1.14	1.46	1.78
Lower Lead Width	B	.014	.018	.022	0.36	0.46	0.56
Overall Row Spacing	eB	.310	.370	.430	7.87	9.40	10.92
Mold Draft Angle Top	$\alpha$	5	10	15	5	10	15
Mold Draft Angle Bottom	$\beta$	5	10	15	5	10	15

\*Controlling Parameter

Notes:

Dimensions D and E1 do not include mold flash protrusions. Mold flash or protrusions shall not exceed .010" (0.254mm) per side.

JEDEC Equivalent: MS-001

8-Lead Plastic Small Outline (SM) – Medium, 208 mil (SOIC)

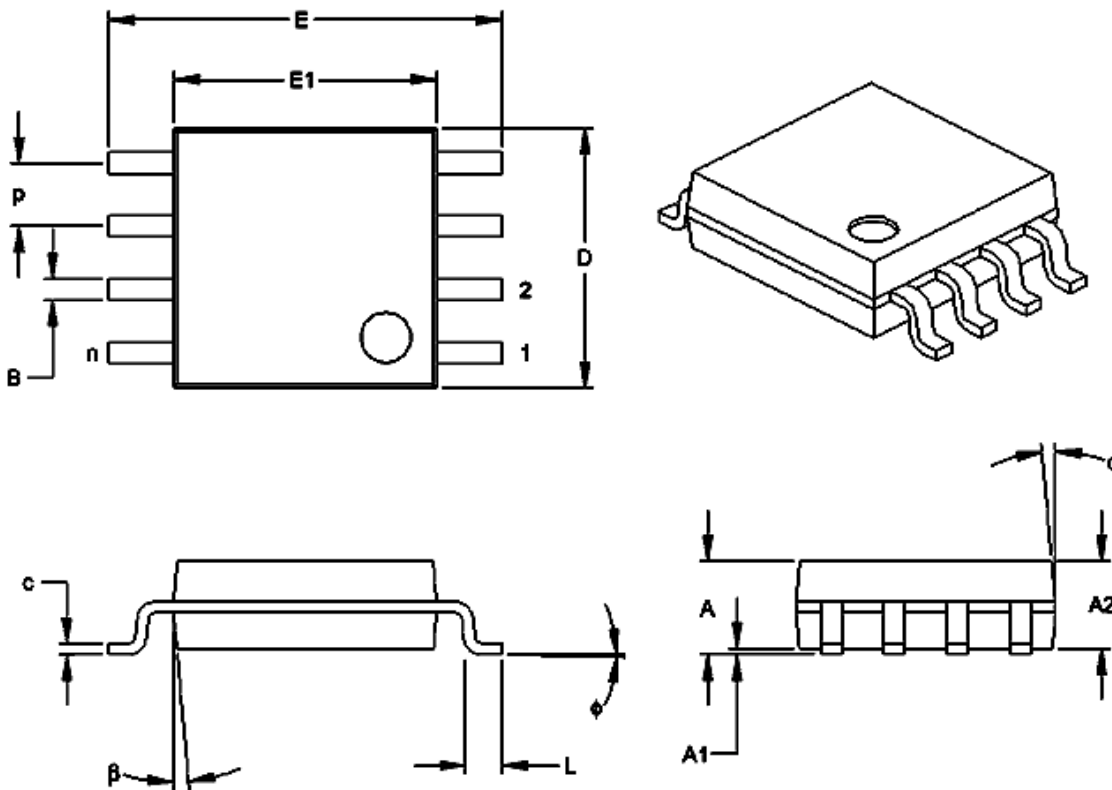

Units		INCHES*			MILLIMETERS		
Dimension Limits		MIN	NOM	MAX	MIN	NOM	MAX
Number of Pins	n		8			8	
Pitch	P		.050			1.27	
Overall Height	A	.070	.075	.080	1.78	1.97	2.03
Molded Package Thickness	A2	.069	.074	.078	1.75	1.88	1.98
Standoff	A1	.002	.005	.010	0.05	0.13	0.25
Overall Width	E	.300	.313	.325	7.62	7.95	8.26
Molded Package Width	E1	.201	.208	.212	5.11	5.28	5.38
Overall Length	D	.202	.205	.210	5.13	5.21	5.33
Foot Length	L	.020	.025	.030	0.51	0.64	0.76
Foot Angle	$\phi$	0	4	8	0	4	8
Lead Thickness	c	.008	.009	.010	0.20	0.23	0.25
Lead Width	B	.014	.017	.020	0.36	0.43	0.51
Mold Draft Angle Top	$\alpha$	0	12	15	0	12	15
Mold Draft Angle Bottom	$\beta$	0	12	15	0	12	15

\*Controlling Parameter

Notes:

Dimensions D and E1 do not include mold flash protrusions. Mold flash or protrusions shall not exceed .010" (0.254mm) per side.



HTC makes no warranty, express, statutory implied or by description, regarding information set forth herein or regarding the freedom of described devices from patent infringement. HTC makes no warranty or merchantability or fitness for any purposes. HTC reserves right to discontinue production and change specifications and prices at any time and without notice. HTC's products are intended for use in commercial applications. Applications requiring extended temperature range, unusual environmental requirements, or high reliability applications, such as military, medical life-support or life-sustaining equipment, are specifically not recommended without additional processing by HTC for such applications.

High Tech Chips, Inc.

[www.hightechips.com](http://www.hightechips.com)

[info@hightechips.com](mailto:info@hightechips.com)