



32-Channel High Voltage Amplifier Array

Features

- ❑ 32 independent high voltage amplifiers
- ❑ 300V operating voltage
- ❑ 295V output voltage
- ❑ 2.2V/ μ s typical output slew rate
- ❑ Adjustable output current limit
- ❑ Internal closed loop gain of 72V/V
- ❑ 12M Ω feedback impedance
- ❑ Layout ideal for die applications

Application

- ❑ MEMS (microelectromechanical systems) driver
- ❑ Piezoelectric transducer driver
- ❑ Optical crosspoint switches (using MEMS technology)

General Description

The Supertex HV256 is a 32-channel high voltage amplifier array integrated circuit. It operates on a single high voltage supply, up to 300V and two low voltage supplies, V_{DD} and V_{NN} .

The input voltage range is from 0V to 4.096V. The internal closed loop gain is 72V/V giving an output voltage of 295V when 4.096V is applied. Input voltages of up to 5V can be applied but will cause the output to saturate. The maximum output voltage swing is 5V below the V_{PP} high voltage supply. The outputs can drive capacitive loads of up to 3000pF.

The maximum output source and sink current can be adjusted by using two external resistors. An external R_{SOURCE} resistor controls the maximum sourcing current and an external R_{SINK} resistor controls the maximum sinking current. The current limit is approximately 12.5V divided by the external resistor value. The setting is common for all 32 outputs. A low voltage silicon junction diode is made available to help monitor the die temperature.

Block Diagram

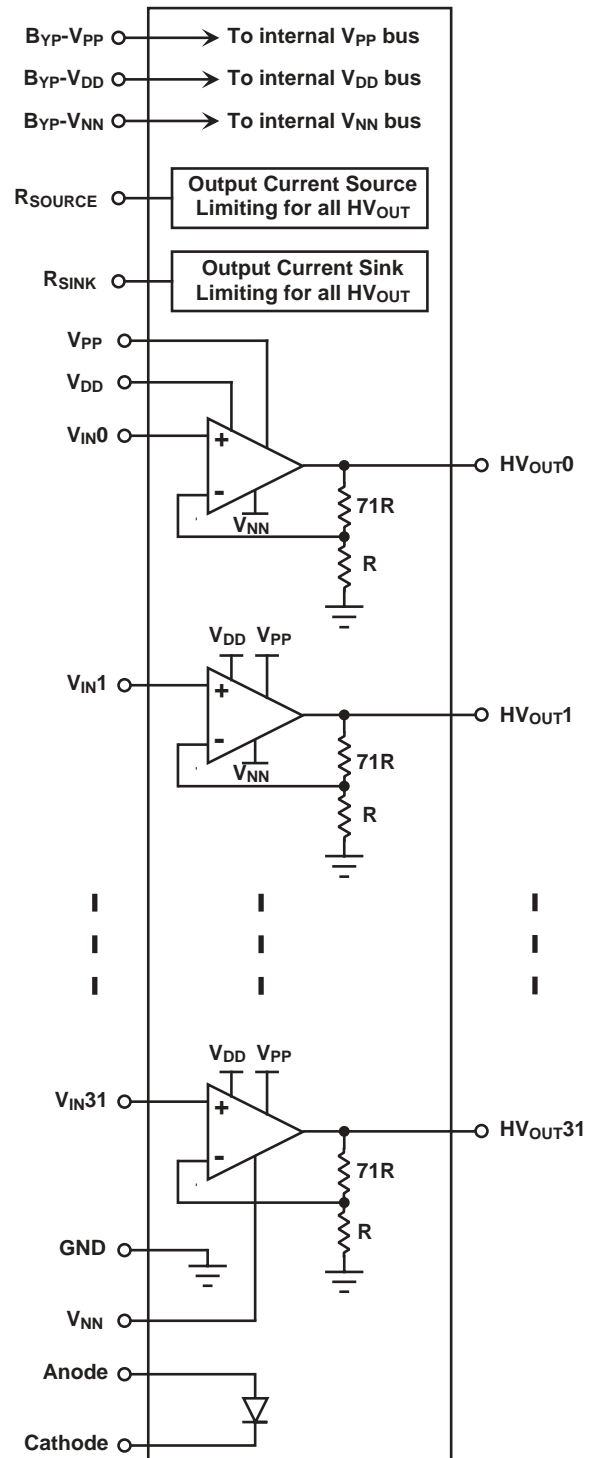

Ordering Information

Device	Maximum Output Voltage	Nominal Closed Loop Gain	Package Options	
			100 Lead MQFP	Die
HV256	295V	72V/V	HV256FG	HV256X

Absolute Maximum Ratings*

V_{PP} , High voltage supply	310V
V_{DD} , Low voltage positive supply	8.0V
V_{NN} , Low voltage negative supply	-7.0V
V_{IN} , Analog input signal	0V to V_{DD}
Storage temperature range	-65°C to 150°C
Maximum junction temperature	150°C

*Absolute Maximum Ratings are those values beyond which damage to the device may occur. Functional operation under these conditions is not implied. Continuous operation of the device at the absolute rating level may affect device reliability. All voltages are referenced to device ground.

Electrical Characteristics (Over operating conditions unless otherwise noted.)

Symbol	Parameter	Min	Typ	Max	Units	Conditions
--------	-----------	-----	-----	-----	-------	------------

Operating Conditions

V_{PP}	High voltage positive supply	125		300	V	
V_{DD}	Low voltage positive supply	6.0		7.5	V	
V_{NN}	Low voltage negative supply	-4.5		-6.5	V	
I_{PP}	V_{PP} supply current			0.8	mA	$V_{PP}=300V$, All $HV_{OUT}=0V$, No Load
I_{DD}	V_{DD} supply current			4.3	mA	$V_{DD} = 6.0V$ to $7.5V$
I_{NN}	V_{NN} supply current	-5.2			mA	$V_{NN} = -4.5V$ to $-6.5V$
T_J	Junction temperature range	-10		125	°C	

High Voltage Amplifier

HV_{OUT}	HV_{OUT} voltage swing	0		$V_{PP}-5$	V	
V_{IN}	Input voltage range	0		5.00	V	
V_{INOS}	HV_{OUT} DC offset			± 50	mV	Input referred.
SR	HV_{OUT} slew rate rise		2.2		V/ μs	No Load
	HV_{OUT} slew rate fall		2.0		V/ μs	No Load
BW	HV_{OUT} -3dB channel bandwidth		4.0		KHz	$V_{PP}=300V$
A_O	Open loop gain	70	100		dB	
A_V	Closed loop gain	68.4	72.0	75.6	V/V	
R_{FB}	Feedback resistance from HV_{OUT} to ground	9.6	12		M Ω	
C_{LOAD}	HV_{OUT} capacitive load	0		3000	pF	
I_{SOURCE}	HV_{OUT} sourcing current limiting range	385	550	715	μA	$R_{SOURCE}=25K\Omega$
I_{SINK}	HV_{OUT} sinking current limiting range	385	550	715	μA	$R_{SINK}=25K\Omega$
R_{SOURCE}	External resistance range for setting current source limit	25		250	K Ω	
R_{SINK}	External resistance range for setting current sink limit	25		250	K Ω	
CT_{DC}	DC channel to channel crosstalk	-80			dB	
PSRR	Power supply rejection ratio for V_{PP} , V_{DD} , and V_{NN}	-40			dB	

Diode

Symbol	Parameter	Min	Typ	Max	Units	Conditions
PIV	Peak inverse voltage			5.0	V	cathode to anode
V_F	Forward diode drop			0.8	V	If=2.0mA, anode to cathode
I_F	Forward diode current			2.0	mA	anode to cathode
T_C	V_F temperature coefficient		TBD		mV/° C	anode to cathode

Power Up/Down Sequence

The device can be damaged due to improper power up / down sequence. To prevent damage, please follow the acceptable power up /down sequences and add two external diodes as shown in the diagram below. The first diode is a high voltage diode across V_{PP} and V_{DD} where the anode of the diode is connected to V_{DD} and the cathode of the diode is connected to V_{PP} . Any low current high voltage diode such as a 1N4004 will be adequate. The second diode is a schottky diode across V_{NN} and PGND where the anode of the schottky diode is connected to V_{NN} and the cathode is connected to PGND. Any low current schottky diode such as a 1N5817 will be adequate.

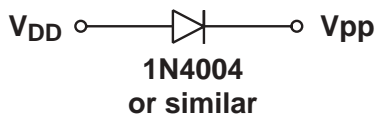

Acceptable Power Up Sequences

- | | | | |
|-------------|-------------|-------------|-----------|
| 1) V_{PP} | 2) V_{NN} | 3) V_{DD} | 4) Inputs |
| 1) V_{DD} | 2) V_{NN} | 3) V_{PP} | 4) Inputs |

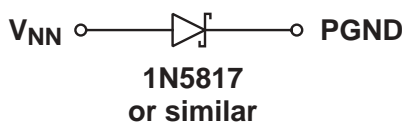

Acceptable Power Down Sequences

- | | | | |
|-----------|-------------|-------------|-------------|
| 1) Inputs | 2) V_{PP} | 3) V_{DD} | 4) V_{NN} |
| 1) Inputs | 2) V_{DD} | 3) V_{NN} | 4) V_{PP} |

Pin Description

V_{PP}	High voltage positive supply. There are two pads.
$B_{YP}-V_{PP}$	A low voltage 1.0 to 10nF decoupling capacitor across V_{PP} and $B_{YP}-V_{PP}$ is required.
V_{DD}	Analog low voltage positive supply. There are four pads.
$B_{YP}-V_{DD}$	A low voltage 1.0 to 10nF decoupling capacitor across V_{DD} and $B_{YP}-V_{DD}$ is required.
V_{NN}	Analog low voltage negative supply. There are four pads.
$B_{YP}-V_{NN}$	A low voltage 1.0 to 10nF decoupling capacitor across V_{NN} and $B_{YP}-V_{NN}$ is required.
GND	Device ground. There are four pads.
R_{SOURCE}	External resistor from R_{SOURCE} to V_{NN} sets output current sourcing limit. Current limit is approximately 12.5V divided by R_{SOURCE} resistor value.
R_{SINK}	External resistor from R_{SINK} to V_{NN} sets output current sinking limit. Current limit is approximately 12.5V divided by R_{SINK} resistor value.
Anode	Anode side of a low voltage silicon diode that can be used to monitor die temperature.
Cathode	Cathode side of a low voltage silicon diode that can be used to monitor die temperature.
$V_{IN}0$ to $V_{IN}31$	Amplifier inputs.
$HV_{OUT}0$ to $HV_{OUT}31$	Amplifier outputs.

Pin Configuration

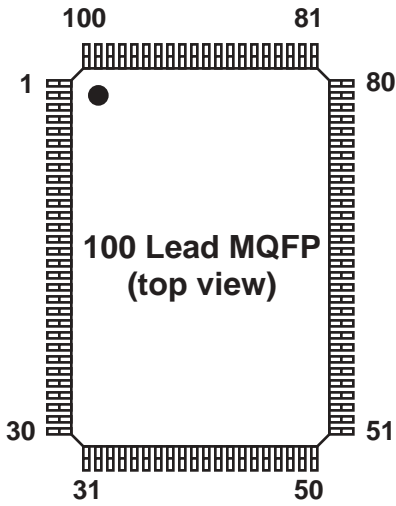

Pin Configuration

Pin #	Function
1	HV _{OUT} 31
2	HV _{OUT} 30
3	HV _{OUT} 29
4	HV _{OUT} 28
5	HV _{OUT} 27
6	HV _{OUT} 26
7	HV _{OUT} 25
8	HV _{OUT} 24
9	HV _{OUT} 23
10	HV _{OUT} 22
11	HV _{OUT} 21
12	HV _{OUT} 20
13	HV _{OUT} 19
14	HV _{OUT} 18
15	HV _{OUT} 17
16	HV _{OUT} 16
17	HV _{OUT} 15
18	HV _{OUT} 14
19	HV _{OUT} 13
20	HV _{OUT} 12
21	HV _{OUT} 11
22	HV _{OUT} 10
23	HV _{OUT} 9
24	HV _{OUT} 8
25	HV _{OUT} 7

Pin #	Function
26	HV _{OUT} 6
27	HV _{OUT} 5
28	HV _{OUT} 4
29	HV _{OUT} 3
30	HV _{OUT} 2
31	HV _{OUT} 1
32	HV _{OUT} 0
33	V _{PP}
34	NC
35	NC
36	Cathode
37	Anode
38	NC
39	Gnd
40	V _{NN}
41	NC
42	V _{DD}
43	Gnd
44	V _{NN}
45	V _{DD}
46	NC
47	NC
48	V _{IN} 0
49	V _{IN} 1
50	V _{IN} 2

Pin #	Function
51	V _{IN} 3
52	V _{IN} 4
53	V _{IN} 5
54	V _{IN} 6
55	V _{IN} 7
56	V _{IN} 8
57	V _{IN} 9
58	V _{IN} 10
59	V _{IN} 11
60	V _{IN} 12
61	V _{IN} 13
62	V _{IN} 14
63	V _{IN} 15
64	V _{IN} 16
65	V _{IN} 17
66	V _{IN} 18
67	V _{IN} 19
68	V _{IN} 20
69	V _{IN} 21
70	V _{IN} 22
71	V _{IN} 23
72	V _{IN} 24
73	V _{IN} 25
74	V _{IN} 26
75	V _{IN} 27

Pin #	Function
76	V _{IN} 28
77	V _{IN} 29
78	V _{IN} 30
79	V _{IN} 31
80	NC
81	NC
82	NC
83	NC
84	NC
85	NC
86	Gnd
87	V _{DD}
88	V _{NN}
89	Gnd
90	NC
91	V _{DD}
92	Byp-V _{NN}
93	Byp-V _{DD}
94	V _{NN}
95	NC
96	NC
97	R _{SINK}
98	R _{SOURCE}
99	Byp-V _{PP}
100	V _{PP}

NC=No Connect.

Pad Configuration (Not Drawn to Scale)

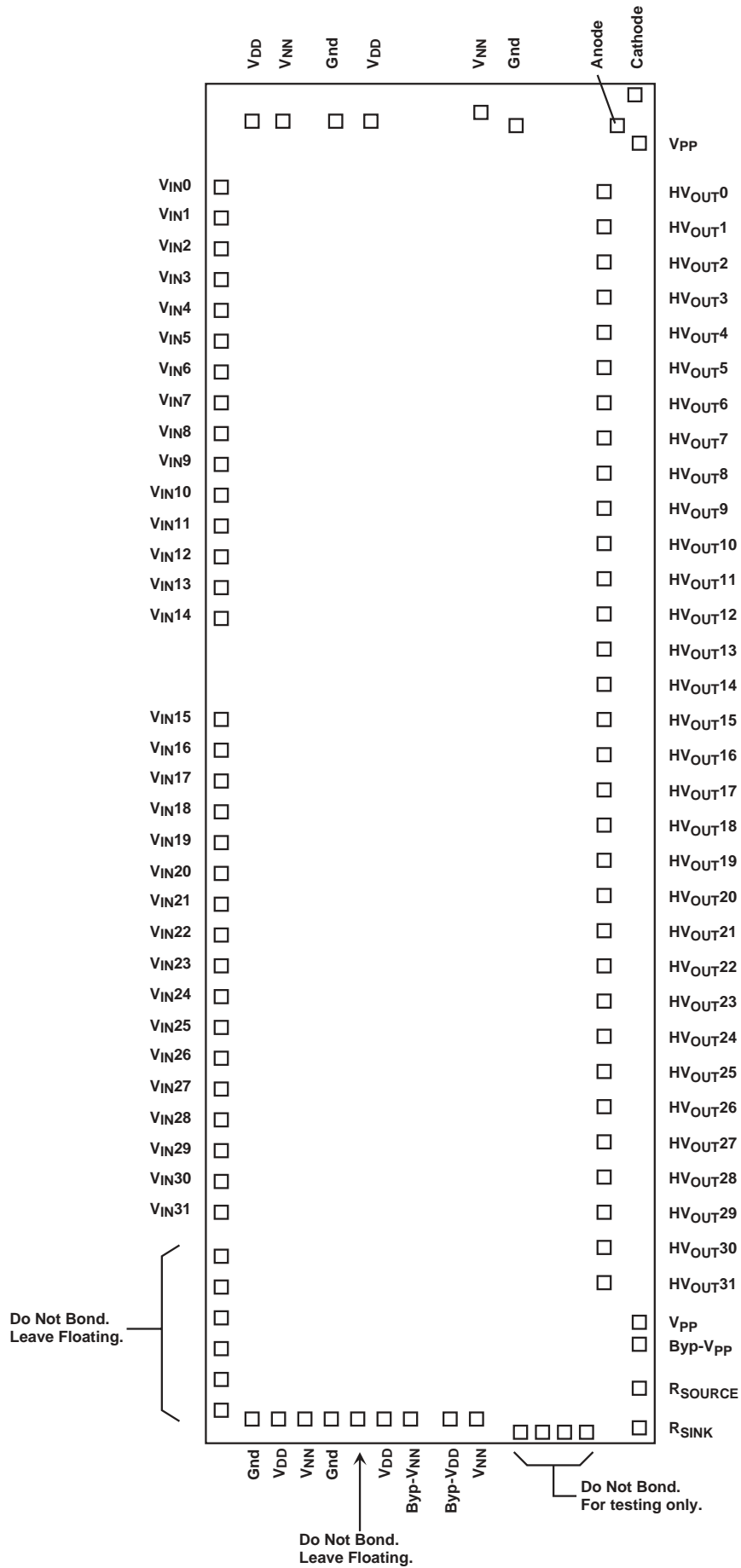

Pad Coordinates

Chip Size: 17004 μ m x 5480 μ m
Center of die is (0,0)

Pad Name	X (μ m)	Y (μ m)
V _{IN} 0	-7532.5	-2514.5
V _{IN} 1	-7127.5	-2514.5
V _{IN} 2	-6722.5	-2514.5
V _{IN} 3	-6317.5	-2514.5
V _{IN} 4	-5912.5	-2514.5
V _{IN} 5	-5507.5	-2514.5
V _{IN} 6	-5102.5	-2514.5
V _{IN} 7	-4697.5	-2514.5
V _{IN} 8	-4292.5	-2514.5
V _{IN} 9	-3887.5	-2514.5
V _{IN} 10	-3482.5	-2514.5
V _{IN} 11	-3077.5	-2514.5
V _{IN} 12	-2672.5	-2514.5
V _{IN} 13	-2267.5	-2514.5
V _{IN} 14	-1862.5	-2514.5
V _{IN} 15	-886.5	-2514.5
V _{IN} 16	-481.5	-2514.5
V _{IN} 17	-76.5	-2514.5
V _{IN} 18	328.5	-2514.5
V _{IN} 19	733.5	-2514.5
V _{IN} 20	1138.5	-2514.5
V _{IN} 21	1543.5	-2514.5
V _{IN} 22	1948.5	-2514.5
V _{IN} 23	2353.5	-2514.5
V _{IN} 24	2758.5	-2514.5
V _{IN} 25	3163.5	-2514.5
V _{IN} 26	3568.5	-2514.5
V _{IN} 27	3973.5	-2514.5
V _{IN} 28	4378.5	-2514.5

Pad Name	X (μ m)	Y (μ m)
V _{IN} 29	4783.5	-2514.5
V _{IN} 30	5188.5	-2514.5
V _{IN} 31	5593.5	-2514.5
Gnd	8320	-2150
V _{DD}	8320	-1785.5
V _{NN}	8320	-1485
Gnd	8300	-1185.5
V _{DD}	8300	-519.5
Byp-V _{NN}	8300	-219.5
Byp-V _{DD}	8300	295.5
V _{NN}	8300	595.5
R _{SINK}	8340	2538
R _{SOURCE}	7860	2538
Byp-V _{PP}	7313	2538
V _{PP}	7013	2538
HV _{OUT} 31	6512.0	2129.5
HV _{OUT} 30	6065.0	2129.5
HV _{OUT} 29	5618.0	2129.5
HV _{OUT} 28	5171.0	2129.5
HV _{OUT} 27	4724.0	2129.5
HV _{OUT} 26	4277.0	2129.5
HV _{OUT} 25	3830.0	2129.5
HV _{OUT} 24	3383.0	2129.5
HV _{OUT} 23	2936.0	2129.5
HV _{OUT} 22	2489.0	2129.5
HV _{OUT} 21	2042.0	2129.5
HV _{OUT} 20	1595.0	2129.5
HV _{OUT} 19	1148.0	2129.5
HV _{OUT} 18	701.0	2129.5

Pad Name	X (μ m)	Y (μ m)
HV _{OUT} 17	254.0	2129.5
HV _{OUT} 16	-193.0	2129.5
HV _{OUT} 15	-640.0	2129.5
HV _{OUT} 14	-1087.0	2129.5
HV _{OUT} 13	-1534.0	2129.5
HV _{OUT} 12	-1981.0	2129.5
HV _{OUT} 11	-2428.0	2129.5
HV _{OUT} 10	-2875.0	2129.5
HV _{OUT} 9	-3322.0	2129.5
HV _{OUT} 8	-3769.0	2129.5
HV _{OUT} 7	-4216.0	2129.5
HV _{OUT} 6	-4663.0	2129.5
HV _{OUT} 5	-5110.0	2129.5
HV _{OUT} 4	-5557.0	2129.5
HV _{OUT} 3	-6004.0	2129.5
HV _{OUT} 2	-6451.0	2129.5
HV _{OUT} 1	-6898.0	2129.5
HV _{OUT} 0	-7345.5	2129.5
V _{PP}	-7693.5	2536.5
Cathode	-8072.5	2488.5
Anode	-7803	2236.5
Gnd	-7825.5	725.5
V _{NN}	-7921.5	425.5
V _{DD}	-7837	-972.5
Gnd	-7817	-1390.5
V _{NN}	-7823	-1779
V _{DD}	-7823	-2080.5