

**OVER CURRENT SENSING IC**

**Features**

- Floating channel up to +600V
- Monolithic integration
- Overcurrent sensing through shunt resistor
- Low IQBS allows the boot strap power supply
- Independent fast 1  $\mu$ sec overcurrent trip signal
- High common mode noise immunity
- Input overvoltage protection for IGBT short circuit condition
- Open Drain outputs

**Description**

IR2170(S) is the monolithic over current sensing IC designed for motor drive applications. It senses the motor phase current through an external shunt resistor, detects overcurrent condition, and transfers the signal to the low side. IR's proprietary high voltage isolation technology is implemented to enable the high bandwidth signal processing. The dedicated overcurrent trip ( $\overline{OC}$ ) signal facilitates IGBT short circuit protection. The  $\overline{OC}$  output pulse width can be programmed by the external resistor and capacitor. The open-drain outputs make easy for any interface from 3.3V to 15V.

**Product Summary**

$V_{OFFSET}$	600Vmax
$I_{QBS}$	1mA
Overcurrent trip signal delay	1.5usec (typ)
Overcurrent trip level	+/-260mV (typ.)

**Packages**

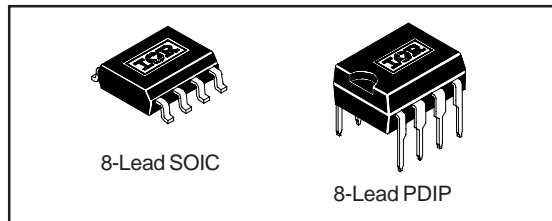

**Typical Application**

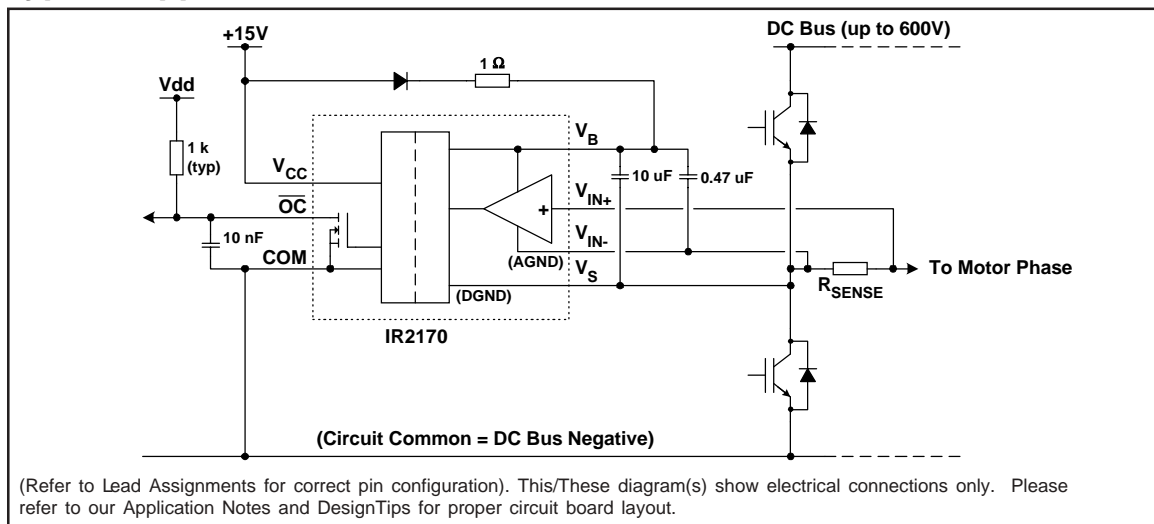

## Absolute Maximum Ratings

Absolute maximum ratings indicate sustained limits beyond which damage to the device may occur. All voltage parameters are absolute voltages referenced to COM, all currents are defined positive into any lead. The thermal resistance and power dissipation ratings are measured under board mounted and still air conditions.

Symbol	Definition	Min.	Max.	Units	
V <sub>S</sub>	High side offset voltage	-0.3	600	V	
V <sub>BS</sub>	High side floating supply voltage	-0.3	25		
V <sub>CC</sub>	Low side and logic fixed supply voltage	-0.3	25		
V <sub>IN</sub>	Maximum input voltage between V <sub>IN+</sub> and V <sub>IN-</sub>	-5	5		
V <sub>OC</sub>	Overcurrent output voltage	COM -0.3	V <sub>CC</sub> +0.3		
V <sub>IN-</sub>	V <sub>IN-</sub> input voltage (note 1)	V <sub>S</sub> -5	V <sub>B+</sub> 0.3		
dV/dt	Allowable offset voltage slew rate	—	50	V/ns	
P <sub>D</sub>	Package power dissipation @ T <sub>A</sub> ≤ +25°C	8 lead SOIC	—	.625	W
		8 lead PDIP	—	1.0	
R <sub>thJA</sub>	Thermal resistance, junction to ambient	8 lead SOIC	—	200	°C/W
		8 lead PDIP	—	125	
T <sub>J</sub>	Junction temperature	—	150	°C	
T <sub>S</sub>	Storage temperature	-55	150		
T <sub>L</sub>	Lead temperature (soldering, 10 seconds)	—	300		

Note 1: Capacitors are required between V<sub>B</sub> and V<sub>in-</sub>, and between V<sub>B</sub> and V<sub>s</sub> pins when bootstrap power is used. The external power supply, when used, is required between V<sub>s</sub> and V<sub>in-</sub>, and between V<sub>B</sub> and V<sub>s</sub> pins.

## Recommended Operating Conditions

The output logic timing diagram is shown in figure 1. For proper operation the device should be used within the recommended conditions.

Symbol	Definition	Min.	Max.	Units
V <sub>B</sub>	High side floating supply voltage	V <sub>S</sub> +13.0	V <sub>S</sub> +20	V
V <sub>S</sub>	High side floating supply offset voltage	note 2	600	
V <sub>OC</sub>	Overcurrent output voltage	COM	V <sub>CC</sub>	
V <sub>CC</sub>	Low side and logic fixed supply voltage	9.5	20	
V <sub>IN</sub>	Input voltage between V <sub>IN+</sub> and V <sub>IN-</sub>	-260	+260	mV
T <sub>A</sub>	Ambient temperature	-40	125	°C

Note 2: Logic operation for V<sub>s</sub> of -5 to +600V. Logic state held for V<sub>s</sub> of -5V to -V<sub>BS</sub>. (Please refer to the Design Tip DT97-3 for more details).

**DC Electrical Characteristics**

$V_{CC} = V_{BS} = 15V$ , and  $T_A = 25^\circ C$  unless otherwise specified.

Symbol	Definition	Min.	Typ.	Max.	Units	Test Conditions
$V_{OC+}$	Overcurrent trip positive input voltage	—	260	—	mV	
$V_{OC-}$	Overcurrent trip negative input voltage	—	-260	—		
$I_{LK}$	Offset supply leakage current	—	—	50	$\mu A$	$V_B = V_S = 600V$
$I_{QBS}$	Quiescent $V_{BS}$ supply current	—	1	2	mA	$V_S = 0V$
$I_{QCC}$	Quiescent $V_{CC}$ supply current	—	—	0.5		$V_O = 1V$
$I_{OCC}$	OC output sink current	10	—	—		$V_O = 0.1V$
		1	—	—		

**AC Electrical Characteristics**

$V_{CC} = V_{BS} = 15V$ , and  $T_A = 25^\circ C$  unless otherwise specified.

Symbol	Definition	Min.	Typ.	Max.	Units	Test Conditions
<b>Proagation delay characteristics</b>						
$t_{doc}$	Propagation delay time of OC	1	1.5	—	$\mu sec$	
$t_{woc}$	Low true pulse width of OC	—	1	—		

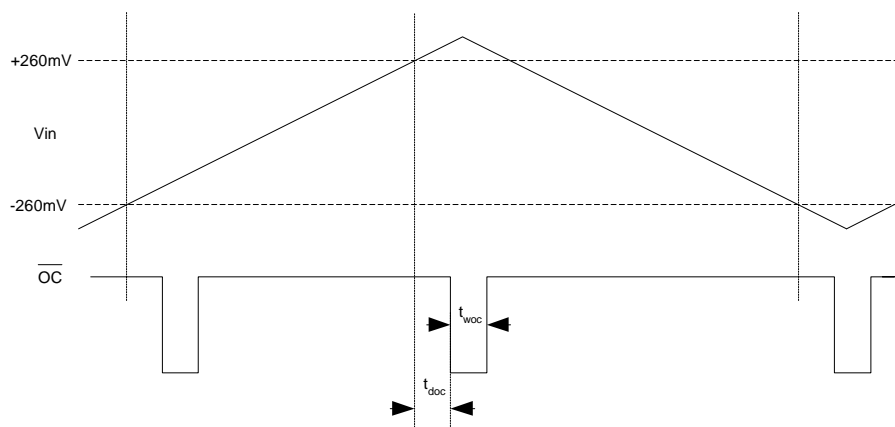

Figure 1. OC Waveform

# IR2170(S)

## Lead Definitions

Symbol	Description
V <sub>CC</sub>	Low side and logic supply voltage
COM	Low side logic ground
V <sub>IN+</sub>	Positive sense input
V <sub>IN-</sub>	Negative sense input
V <sub>B</sub>	High side supply
V <sub>S</sub>	High side return
$\overline{OC}$	Overcurrent output (negative logic)
N.C.	No connection

## Lead Assignments

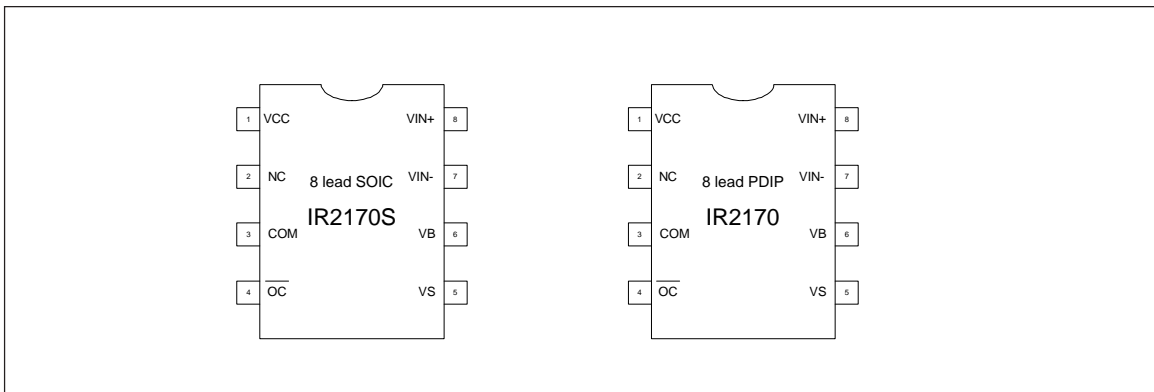

Case outlines

