

DUAL ELECTRONIC VOLUME CONTROL

The KA2250 is a CMOS designed for electronization of dual volumes. It is suitable for M/C, car stereos.

FEATURES

- Wide supply voltage range: $V_{DD} = 6V \sim 12V$ (Backup is possible up to 4V)
- Attenuation can be controlled from 0dB to -66dB by 2dB/step.
- Controlling attenuation by means of the built in osc and the up/down terminals.
- Single power supply operation as well as split power supply operation.

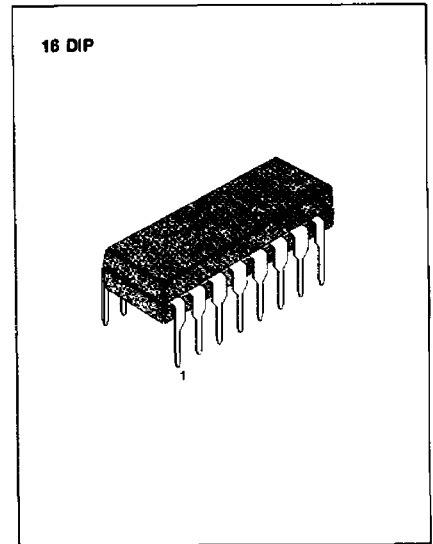

ORDERING INFORMATION

Device	Package	Operating Temperature
KA2250	16DIP	-20°C ~ +70°C

BLOCK DIAGRAM

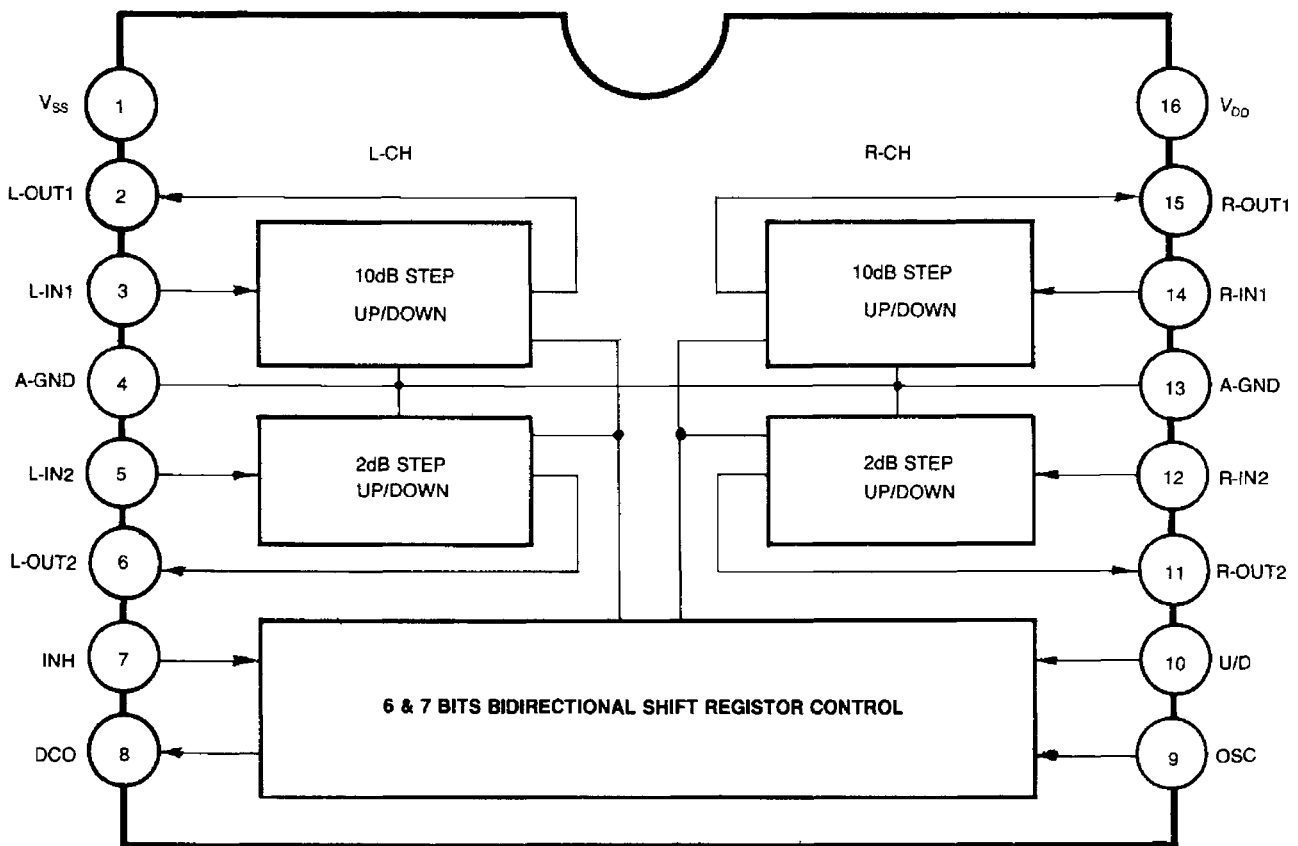

Fig. 1

PIN CONFIGURATION

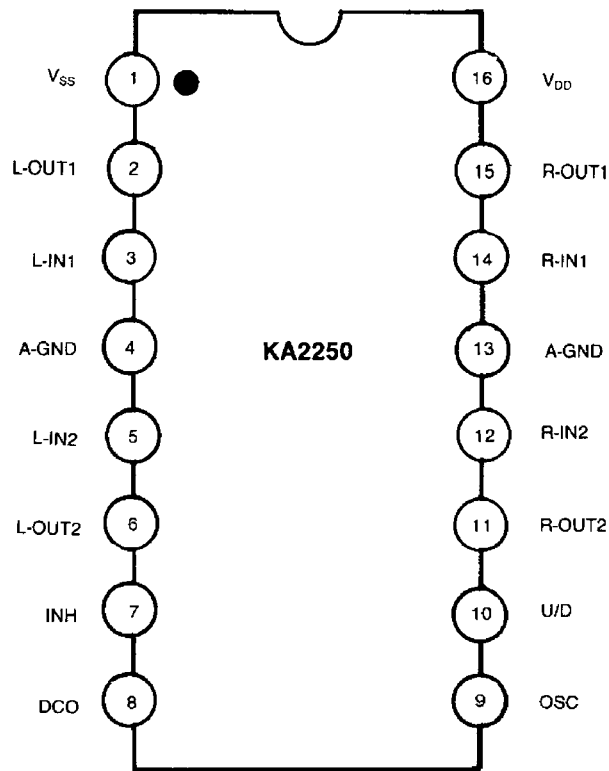

Fig. 2

PIN DESCRIPTION

Pin No.	Symbol	Description
1	V _{SS}	(-) power supply (GND)
2 15	L-OUT1 R-OUT1	10dB/step attenuator output. A signal applied to IN is attenuated in 7 steps from 0dB to 60dB at 10dB
3 14	L-IN1 R-IN1	10dB/step attenuator inputs.
4 13	A-GND	ANALOG GROUND
5 12	L-IN2 R-IN2	2dB/step attenuator inputs
6 11	L-OUT2 R-OUT2	2dB/step attenuator output. A signal applied to IN is attenuated in 5 steps from 0dB to 60dB at 2dB
16	V _{DD}	(+) power supply (V _{DD})
7	INH	When at "H" level, the operates normally.
8	DCO	DC current output for displaying attenuation.
9	OSC	R,C connecting pin for the oscillator.
10	U/D	Attenuation up/down control input.

ABSOLUTE MAXIMUM RATINGS ($T_a = 25^\circ\text{C}$)

Characteristic	Symbol	Value	Unit
Supply Voltage	V_{DD}	13	V
Power Dissipation	P_D	150	mW
Operating Temperature	T_{OPR}	-20 ~ +75	$^\circ\text{C}$
Storage Temperature	T_{STG}	-55 ~ +125	$^\circ\text{C}$
Input Voltage	V_I	$V_{DD} + 0.3 \sim V_{SS} - 0.3$	V

ELECTRICAL CHARACTERISTICS($V_{DD} = 12\text{V}$, $f = 1\text{KHz}$, $T_a = 25^\circ\text{C}$, unless otherwise noted)

Characteristics	Symbol	Test Condition	Min	Typ	Max	Unit
Circuit Current	I_{DD1}	$V_{DD} = 13\text{V}$	0.1	1.0	2.5	mA
	I_{DD2}	$V_{DD} = 6\text{V}$	0.1	0.8	2.0	
Attenuator Resistor	R_{ATT1}	pin3-pin4 pin14-pin13	25	50	70	$\text{K}\Omega$
	R_{ATT2}	pin5-pin4 pin12-pin13	10	20	30	
Backup Current	I_{BACKUP}	$V_{DD} = 4\text{V}$, s/w1 = b			10	μA
Input High Voltage	V_{IH}	up (down) s/w on	9.6	11.8	12.3	V
Input Low Voltage	V_{IL}	s/w1 = a		0.5	1.2	
Total Harmonic Distortion	THD	$V_I = 1.0\text{Vpp}$, $A_{TT} = 10\text{dB}$, $f = 15\text{KHz}$		0.005	0.01	%
Attenuator error	$V_{ATT(ERR)}$	$V_o = 5\text{step}$	-2	0	2	dB
Max input Amplitude	$V_{I(MAX)}$	THD = 1%, $V_{OL} = \text{max}$	1.0	2.5	4.0	Vrms
DCO output current	$I_{O(DCO)}$	1 step	70	100	140	μA
Cross talk	CT	$A_{TT} = -10\text{dB}$	55	65		dB
Operating frequency	f_{OSC1}	up/sw on, s/w 3 = a	5	13	20	Hz
	f_{OSC2}	s/w 3 = d	9	11	13	KHz

TEST CIRCUIT

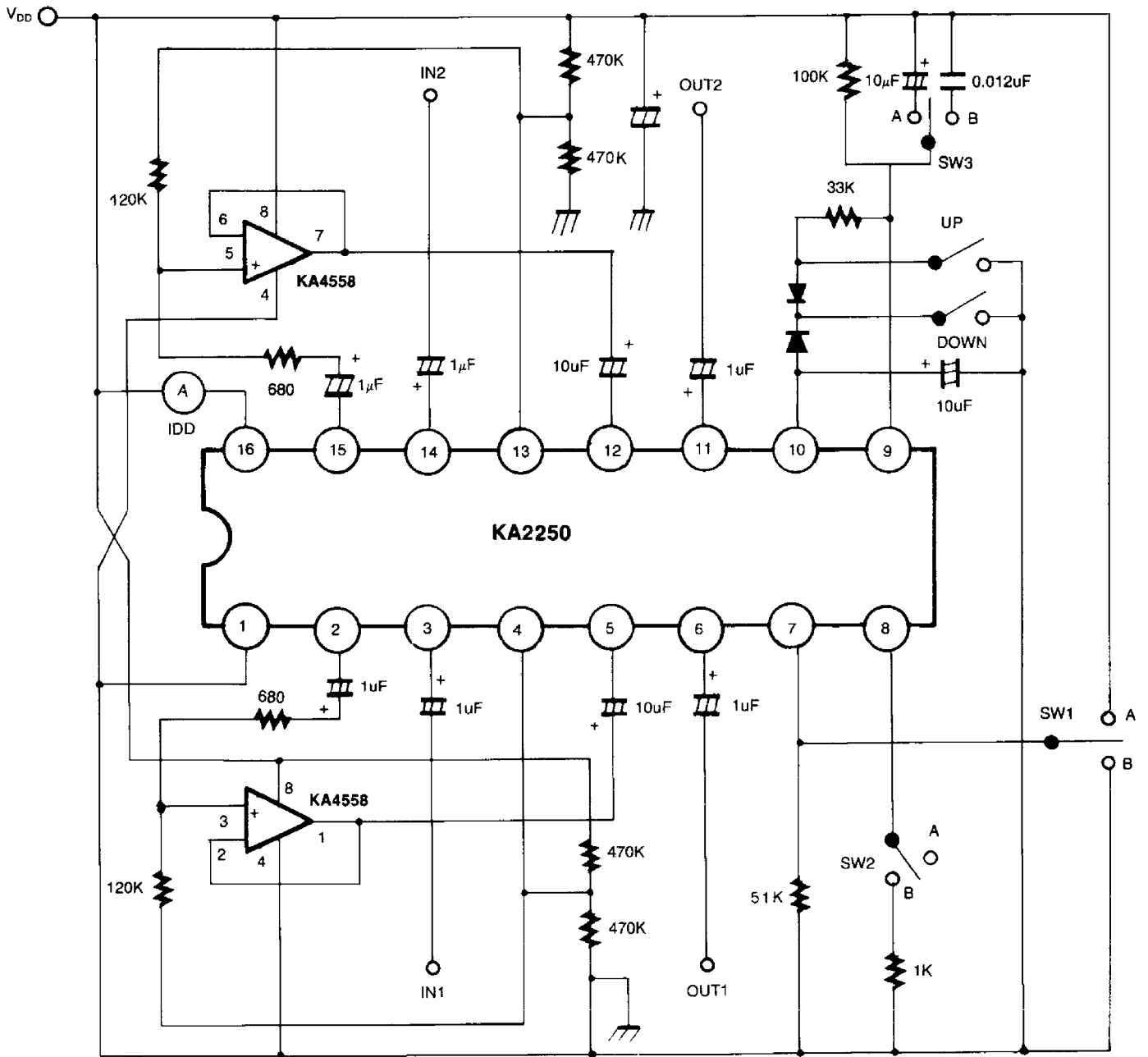

Fig. 3

2. Attenuation Display Output

The KA2250 is provided with the DC current output pin for displaying attenuation.

There are 13 steps attenuation with 0dB ~ -∞

The current of each step is increased or decreased approximately 100uA.

STEP	DCO	ATTENUATION
0	0	-64dB ~ -∞
1	$I = 100\mu\text{A} + 30\mu\text{A}$	-60dB ~ -62dB
2	$2 \cdot I$	-54dB ~ -58dB
3	$3 \cdot I$	-50dB ~ -52dB
4	$4 \cdot I$	-44dB ~ -48dB
5	$5 \cdot I$	-40dB ~ -42dB
6	$6 \cdot I$	-34dB ~ -38dB
7	$7 \cdot I$	-30dB ~ -32dB
8	$8 \cdot I$	-24dB ~ -28dB
9	$9 \cdot I$	-20dB ~ -22dB
10	$10 \cdot I$	-14dB ~ -18dB
11	$11 \cdot I$	-10dB ~ -12dB
12	$12 \cdot I$	-4dB ~ -8dB
13	$13 \cdot I$	0dB ~ -2dB

*Current value may fluctuate depending upon IC.

When high precision is required use a variable resistor as a load resistor.

3. BACKUP

On the KA2250, when power is off (S1 open) or the INH pin is set as "L" ($-V_{SS}$) level, all I/O pin are shut off and current consumption is reduced to the minimum.

The backup by means of a capacitor (C1) becomes possible in this condition. Fig 6. shows an example of application when a backup capacitor is used.

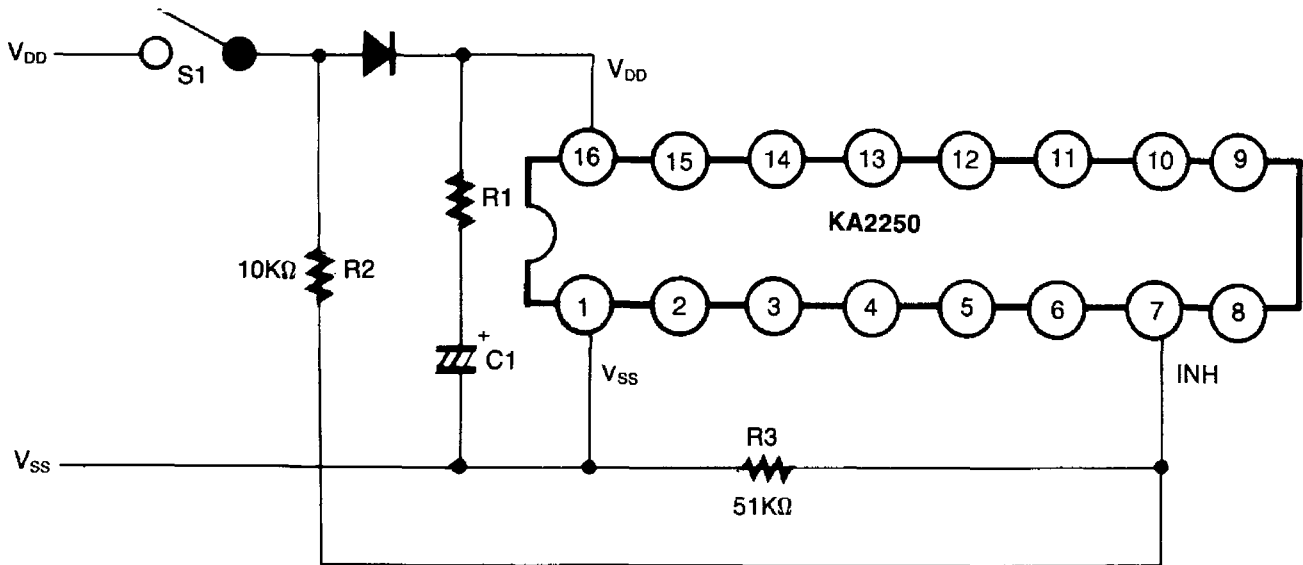

Fig. 6

*If $V_{DD}-V_{SS}$ become below 4.0V, the backup is impossible.

4. INITIALIZATION WHEN POWER ON

The KA2250 built-in auto-initializing function for initialization when power on. As the initializing system through detection of supply voltage level is adopted, if rise of power supply is too fast, the initialization may not be fully effected. (no external initialization is necessary.) In additions for effective initialization it is necessary that the INH pin is raised simultaneously with supply voltage. Further, the initializing level is -40dB . It is recommended to rise supply voltage and the INH pin as illustrated Fig. 7.

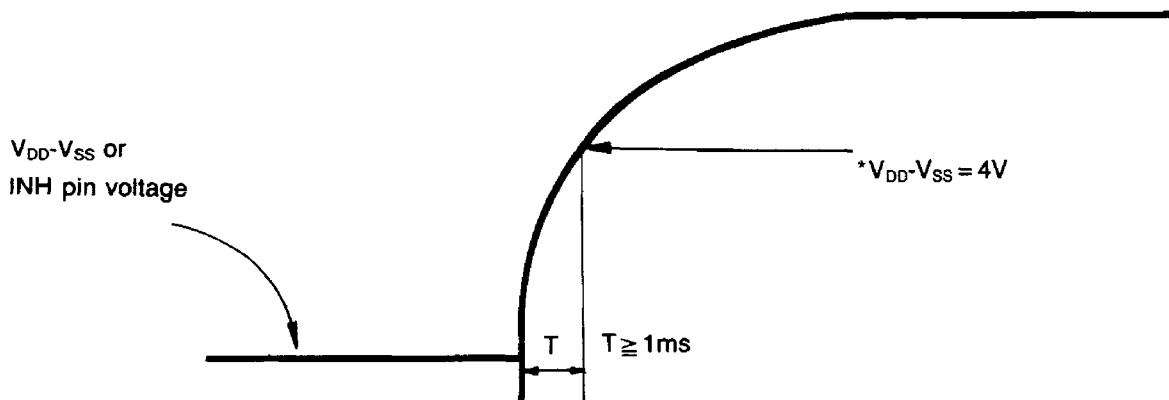

Fig. 7

If the voltage between V_{DD} and V_{SS} is below 4.0V, the auto-initializing function is actuated.

5. POWER SUPPLY

Single power supply operation as well as split power supply operation.

1) SPLIT POWER SUPPLY

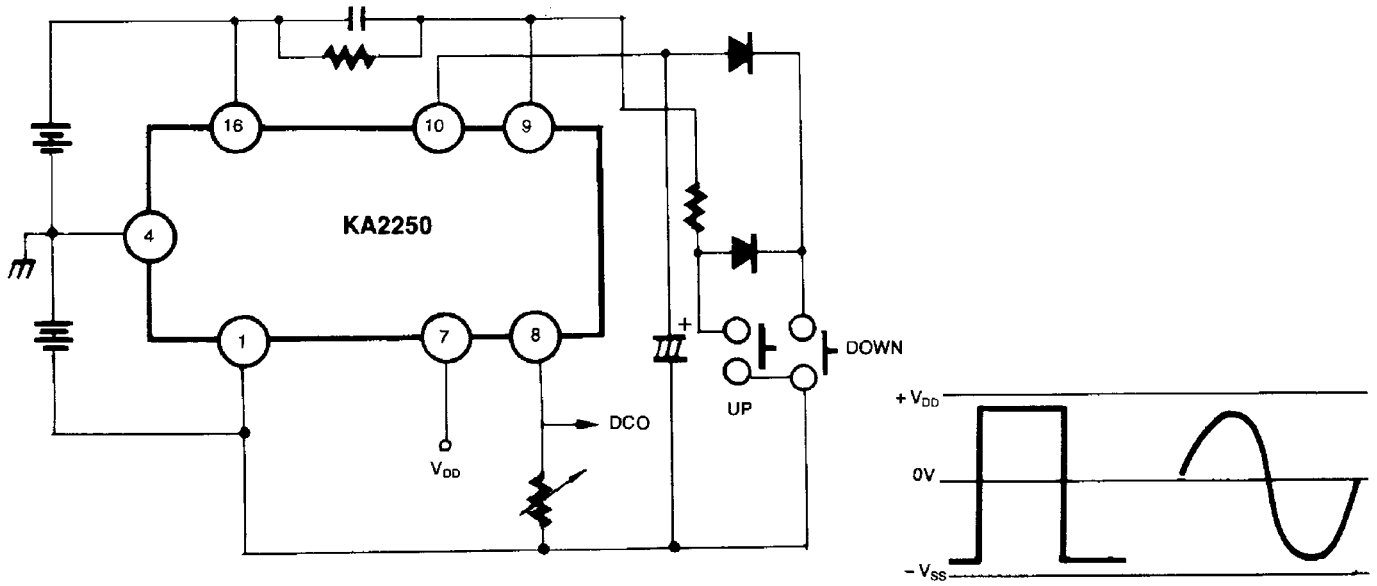

Fig. 8

2) SINGLE POWER SUPPLY

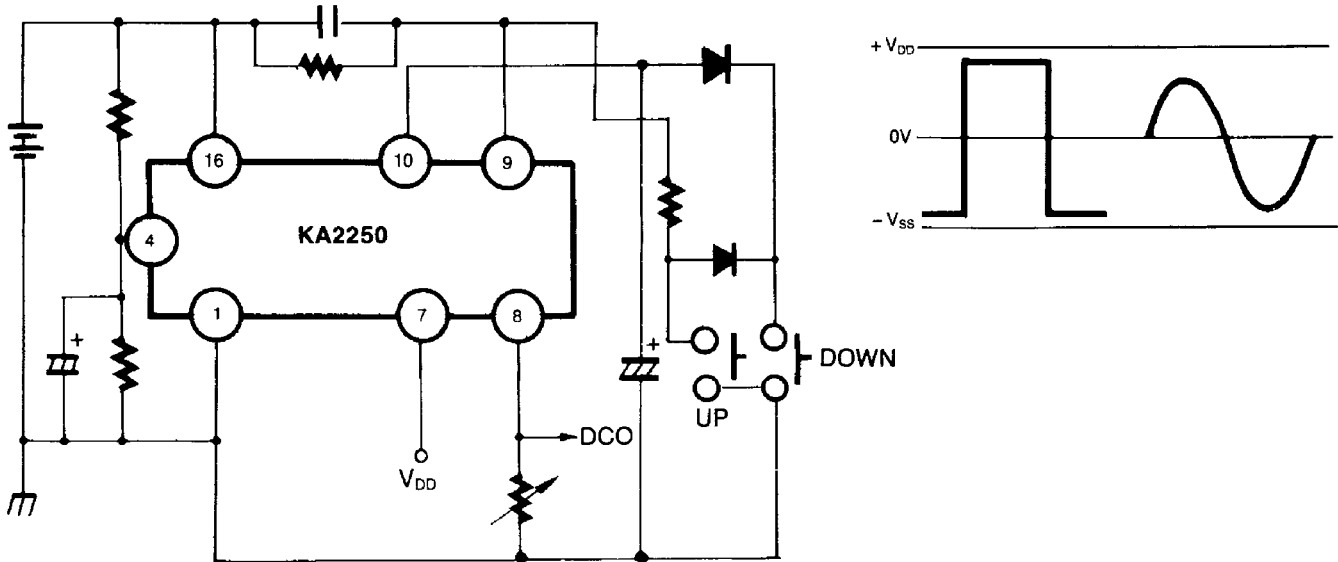

Fig. 9