

VIDEO IF PROCESSOR FOR B/W TVs

The KA2912 is a silicon monolithic integrated circuit designed for the VIF stage in B/W television receivers. This IC has all functions, including a video IF amplifier, video low-level detector, RF AGC, IF AGC and noise canceller. This IC is encapsulated a 14-pin dual in-line package with heat sink.

FEATURES

- High input sensitivity: Typ 30 dB μ .
- It can be used both of keyed type AGC and peak type AGC.
- It can be operated with the power supply voltage above 7V.
- Since the video detector has a wide bandwidth, it's suitable for the sound carrier frequency of 4.5, 5.5, 6.0, 6.5 MHz.
- As input is differential mode, it can be used with an SAW filter.
- All functions of the VIF stage are provided by this single chip IC. This will realize reduction of assembly costs as well as reduction of the number of external components.

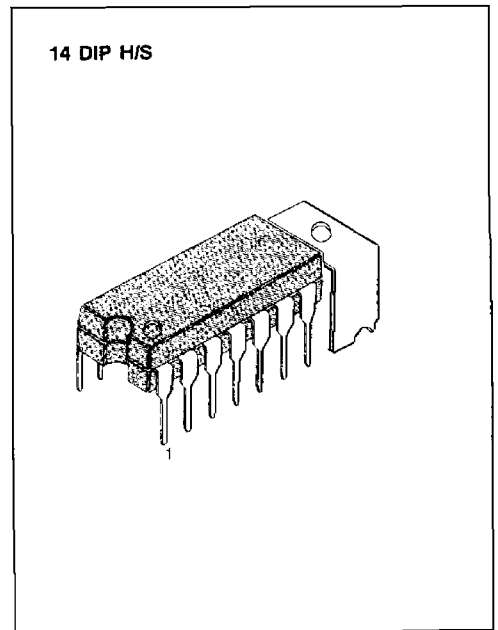

ORDERING INFORMATION

Device	Package	Operating Temperature
KA2912	14 DIP H/S	-20 ~ +75°C

BLOCK DIAGRAM

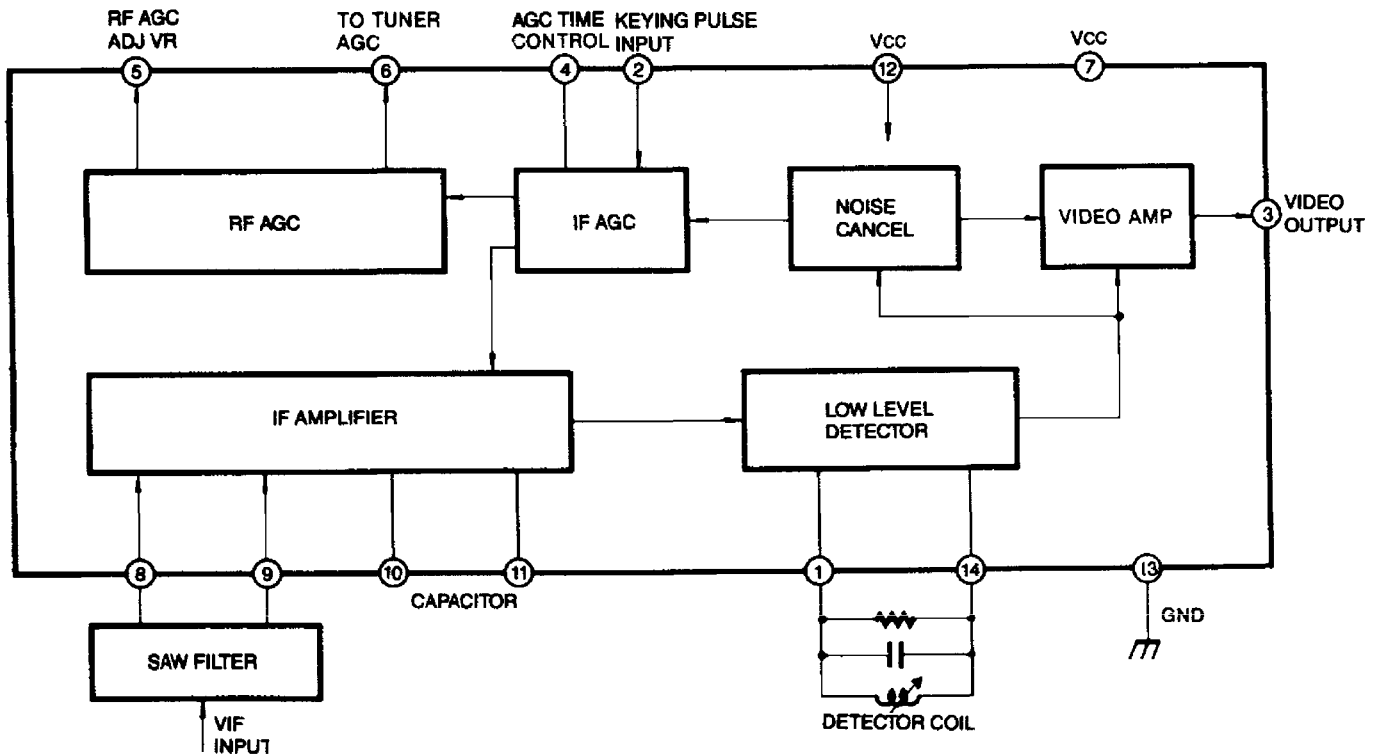

Fig. 1

ABSOLUTE MAXIMUM RATINGS (T_a = 25°C)

Characteristic	Symbol	Value	Unit
Supply Voltage	V _{CC} (Pin 7)	15	V
Input Singnal Voltage	V _B , V _G	3	V _{P-P}
Power Dissipation	P _D	875 (T _a = 75°C) free air	mW
Operating Temperature	T _{OPR}	- 20 ~ + 70	°C
Storage Temperature	T _{STG}	- 40 ~ + 125	°C

ELECTRICAL CHARACTERISTICS(T_a = 25°C, V_{CC} = 12V, f_p = 45.75MHz, f_m = 400Hz)

Characteristic	Symbol	Test Conditions	Min	Typ	Max	Unit
Total Supply Current	I _{CC}	I ₇ + I ₁₂ , R _A = 150Ω	40	50	60	mA
Input Sensitivity	S _{VI}	MOD = 80%, v _O = 1.4V _{P-P}	—	30	35	dBμ
Maximum Input Voltage	V _{I (MAX)}	MOD = 80%, -1dB Point	100	—	—	dBμ
Video Output Voltage	V _O	MOD = 80%, v _I = 3mVrms	1.0	1.4	1.7	V _{P-P}
Video Output DC Voltage	V _{O (DC)}	No Signal	3.3	3.8	4.3	V
Signal to Noise Ratio	S/N	MOD = 80% - 0% v _I = 3mVrms	40	50	—	dB
RF AGC Voltage (High)	V _{6H}	V ₅ = 0V	8	9	11	V
RF AGC Voltage (Low)	V _{6L}	V ₅ = 7V	—	0	0.5	V
Differential Gain	D.G.	Stair step F _M = 3.58MHz	—	—	10	%
Differential Phase	D.P.	Stair step F _M = 3.58MHz	—	—	10	deg
Video Detector Band Width	G _{V (F)}	-3dB Point	5.5	—	—	MHz
Input Resistance	R _{IN}		—	1.5	—	KΩ
Input Capacitance	C _{IN}		—	3.3	—	pF

INPUT SENSITIVITY

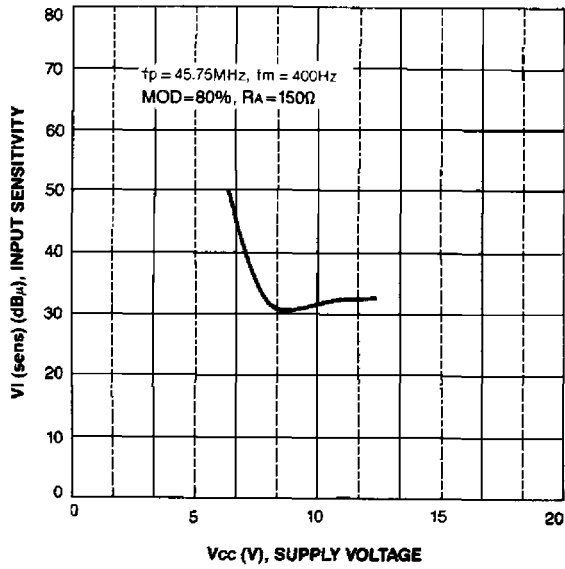

VIDEO DETECTOR OUTPUT VOLTAGE Vs SUPPLY VOLTAGE

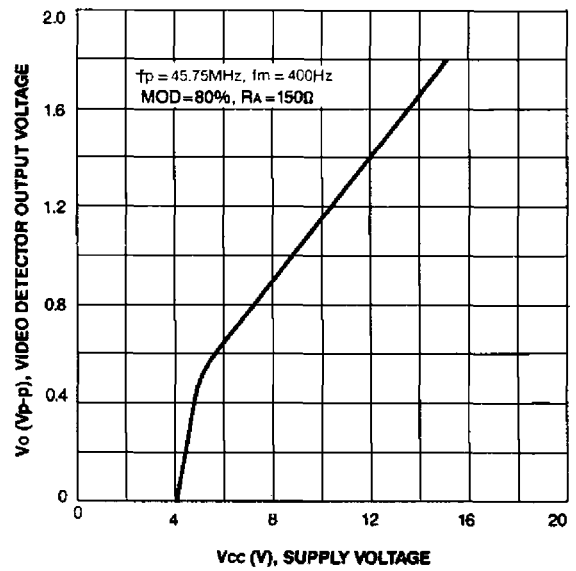

S/N Vs INPUT VOLTAGE

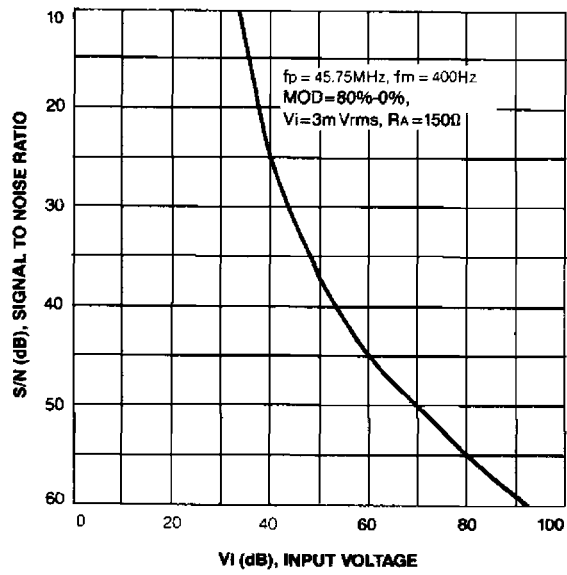

VIDEO DETECTOR OUTPUT VOLTAGE ATTENUATION Vs FREQUENCY

