

QUAD OPERATIONAL AMPLIFIER

The KA3303 series is a monolithic Quad operational amplifier consisting of four independent amplifiers. The device has high gain, internally frequency compensated operational amplifiers designed to operate from a single power supply or dual power supplies over a wide range of voltages. The common mode input range includes the negative supply, thereby eliminating the necessity for external biasing components in many applications.

FEATURES

- Output voltage can swing to GND or negative supply
- Wide power supply range;
 - Single supply of 3.0V to 36V
 - Dual supply of $\pm 1.5V$ to $\pm 18V$
- Electrical characteristics similar to the popular KA741
- CLASS AB output stage for minimal crossover distortion
- Short circuit protected output.

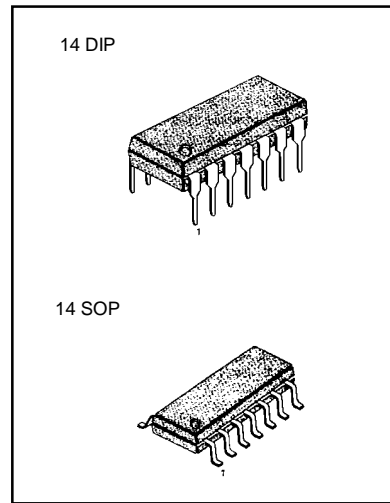

BLOCK DIAGRAM

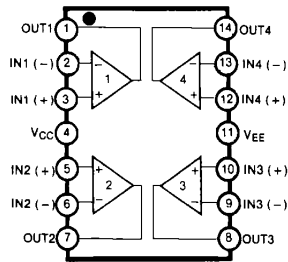

ORDERING INFORMATION

Device	Package	Operating Temperature
KA3403	14 DIP	0 ~ +70°C
KA3403D	14 SOP	
KA3303	14 DIP	-40 ~ +85°C
KA3303D	14 SOP	

SCHEMATIC DIAGRAM

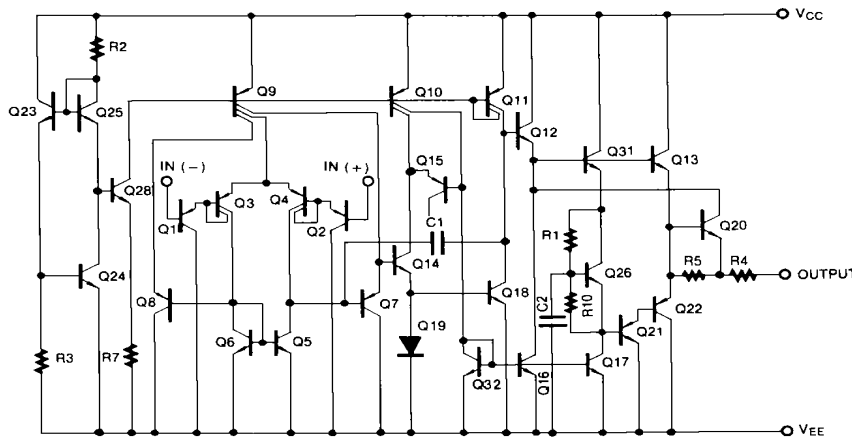

ABSOLUTE MAXIMUM RATINGS

Characteristic	Symbol	Value	Unit
Supply Voltage	V_{CC}	± 18 or $+36$	V
Differential Input Voltage	$V_{I(DIFF)}$	± 36	V
Input Voltage	V_I	± 18	V
Output Short Circuit Duration		Continuous	
Power Dissipation	P_D	670	mW
Operating Temperature KA3303	T_{OPR}	$-40 \sim +85$	$^{\circ}C$
KA3403		$0 \sim +70$	$^{\circ}C$
Storage Temperature	T_{STG}	$-65 \sim +150$	$^{\circ}C$

ELECTRICAL CHARACTERISTICS

($V_{CC} = +15V$, $V_{EE} = -15V$ for KA3403, $V_{CC} = +14V$, $V_{EE} = GND$ for KA3303, $T_A = 25^{\circ}C$, unless otherwise specified)

Characteristic	Symbol	Test Conditions	KA3303			KA3403			Unit
			Min	Typ	Max	Min	Typ	Max	
Input Offset Voltage	V_{IO}			1.5	8.0		1.5	10	mV
		NOTE 1			10			12	
Input Offset Current	I_{IO}			5	75		5	50	nA
		NOTE 1			150			100	
Input Bias Current	I_{BIAS}			30	200		30	200	nA
		NOTE 1			500			400	
Large Signal Voltage Gain	G_V	$V_{O(P-P)} = \pm 10V$ $R_L = 2K\Omega$	20	200		20	200		V/mV
		NOTE 1	15			15			
Input Impedance	R_I		0.3	1.0		0.3	1.0	$M\Omega$	
Output Voltage Swing	$V_{O(P-P)}$	$R_L = 10K\Omega$	+12	+12.5		± 12	± 13.5		V
		$R_L = 2K\Omega$	+10	+12		± 10	± 13		
		$R_L = 2K\Omega$ NOTE 1	+10			± 10			
Input Common Mode Voltage Range	$V_{I(R)}$		12V - V_{EE}	12.5V - V_{EE}		13V - V_{EE}	13.5V - V_{EE}	V	
Common Mode Rejection Ratio	CMRR	$R_S \geq 10K\Omega$	70	90		70	90	dB	
Power Supply Current	I_{CC}	$V_{O(P)} = 0$, $R_L = \infty$		2.8	7.0		2.3	7.0	mA
Output Short Circuit Current	I_{SC}	Each amplifier	± 10	± 30	± 45	± 10	± 20	± 45	mA
Positive Supply Rejection Ratio	PSRR(+)			30	150		30	150	$\mu V/V$
Negative Supply Rejection Ratio	PSRR(-)						30	150	$\mu V/V$
Average Temperature Coefficient of Input Offset Current	$\Delta I_{IO}/\Delta T$			50			50		pA/ $^{\circ}C$
Total Harmonic distortion	THD	$V_{CC} = 5V$, $V_{CE} = -5V$ $F = 1KHz$, Input level = 1.55Vp-p				-	0.1	0.4	%

ELECTRICAL CHARACTERISTICS (Continued)(V_{CC}= +15V, V_{EE}= -15V for KA3403. V_{CC}= +14V, V_{EE}=GND for KA3303, T_A=25°C, unless otherwise specified)

Characteristic	Symbol	Test Conditions	KA3303			KA3403			Unit
			Min	Typ	Max	Min	Typ	Max	
Input Offset Voltage Drift	$\Delta V_{IO}/\Delta T$			10			10	$\mu V/^\circ C$	
Gain Bandwidth	GBW	G _V =1, R _L =2K Ω , V _{O(P-P)} =20V _{P-P} , THD=5%		9.0			9.0	KHz	
Small Signal Bandwidth	BW	G _V =1, R _L =10K Ω , V _{O(P-P)} =50mV		1.0			1.0	MHz	
Slew Rate	SR	G _V =1, V _I = -10V to +10V		0.4			0.4	V/ μ s	
Rise Time	t _{RES}	G _V =1, R _L =10K Ω , V _{O(P-P)} =50mV		0.35			0.35	μ s	
Fall Time	t _F	G _V =1, R _L =10K Ω , V _{O(P-P)} =50mV		0.35			0.35	μ s	
Over Shoot	OS	G _V =1, R _L =10K Ω , V _{O(P-P)} =50mV		20			20	%	
Phase Margin	MPH	G _V =1, R _L =2K Ω , C _L =200pF		60			60	Degress	
Crossover Distortion	CD	V _I =30mV _{P-P} , V _{O(P-P)} =2.0V _{P-P} , f=10KHz		1.0			1.0	5%	

NOTE 1

KA3403: 0 \leq T_A \leq +70°CKA3303: -40 \geq T_A \geq +85°C**ELECTRICAL CHARACTERISTICS**(V_{CC}= 5.0V, V_{EE}= GND, T_A=25°C unless otherwise specified)

Characteristic	Symbol	Test Conditions	KA3303			KA3403			Unit
			Min	Typ	Max	Min	Typ	Max	
Input Offset Voltage	V _{IO}				10		2.0	10	mV
Input Offset Current	I _{IO}				75		30	50	nA
Input Bias Current	I _{BIAS}				500		200	500	nA
Large Signal Open Loop Voltage Gain	G _V	R _L = 2.0K Ω	10	200		10	200		V/mV
Power Supply Rejection Ratio	PSRR				150			150	μ V/V
Output Voltage Range	V _{O(P-P)}	R _L = 10K Ω , V _{CC} = 5.0V R _L = 10K Ω , 5.0V \geq V _{CC} \geq 3.0V	3.3 V _{CC} -2.0	3.5 V _{CC} -1.7		3.3 V _{CC} -2.0	3.5 V _{CC} -1.7		V
Supply Current	I _{CC}			2.5	7.0		2.5	7.0	mA
Channel Separation	CS	f = 1KHz to 20KHz		120			120		dB

TYPICAL PERFORMANCE CHARACTERISTICS

Fig. 1 OPEN LOOP FREQUENCY RESPONSE

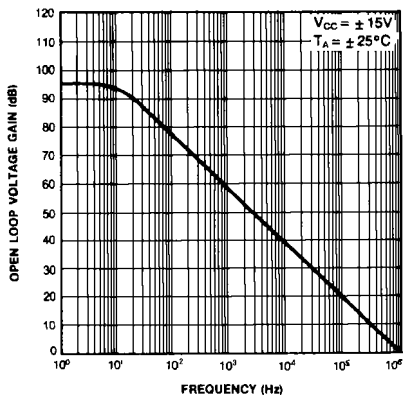

Fig. 2 Wave Response

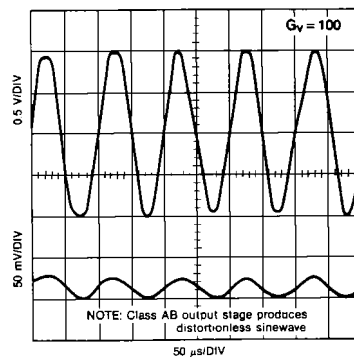

Fig. 3 OUTPUT SWING

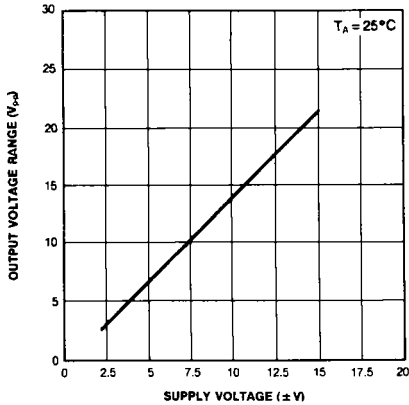

Fig. 4 OUTPUT VOLTAGE vs FREQUENCY

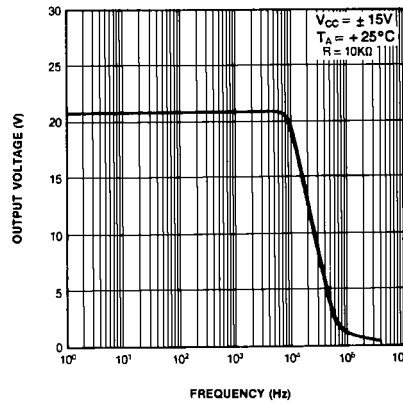

Fig. 5 INPUT BIAS CURRENT vs TEMPERATURE

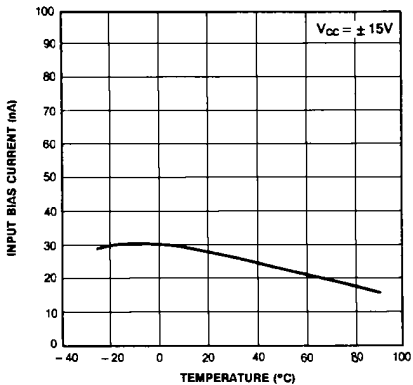
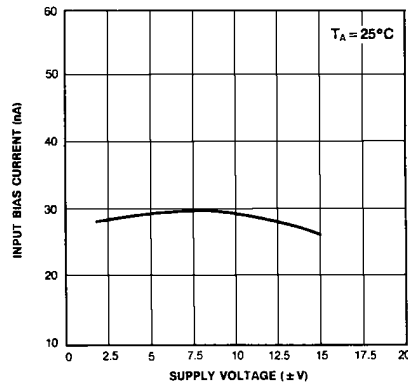
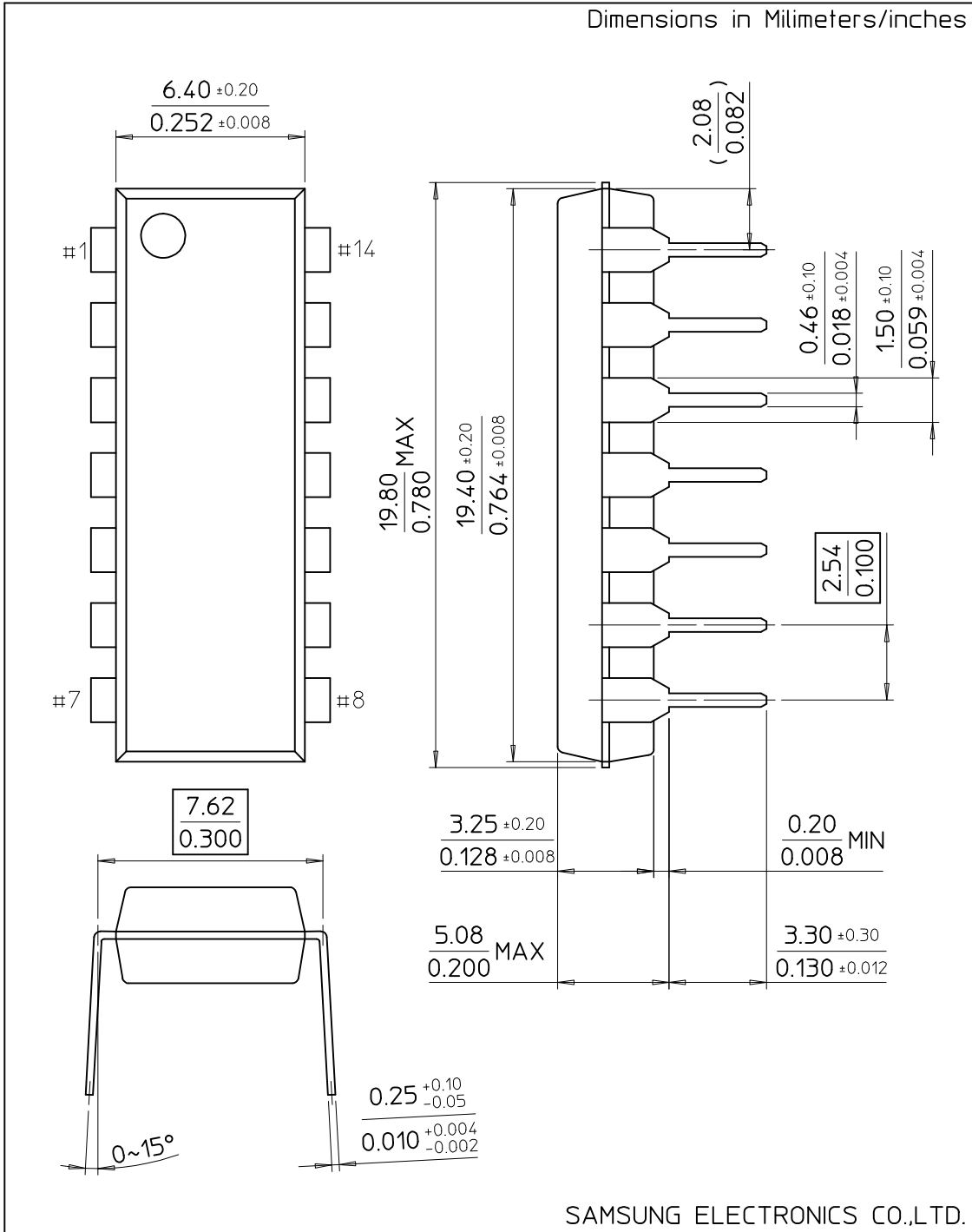

Fig. 6 INPUT BIAS CURRENT vs SUPPLY VOLTAGE



14-DIP-300

Dimensions in Millimeters/inches



14-SOP-225B

Dimensions in Millimeters/inches

