

LOW DROPOUT VOLTAGE REGULATOR

The KA78R33 is a low-dropout voltage regulator suitable for various electronic equipments. It provide constant voltage power source with TO-220 4 lead full mold package. Dropout voltage of KA78R33 is below 0.5v in full rated current(1A). This regulator has various function such as peak current protection, thermal shut down, overvoltage protection and output disable function.

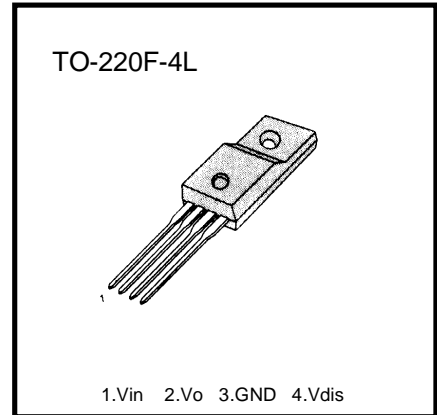

FEATURES

- 1A / 3.3V Output low dropout voltage regulator
- TO220 Full-Mold package (4PIN)
- Overcurrent protection, Thermal shutdown
- Overvoltage protection, Shortcircuit protection
- With output disable function

ORDERING INFORMATION

Device	Package	Operating Temperature
KA78R33	TO-220F-4L	-20°C ~ +80°C

BLOCK DIAGRAM

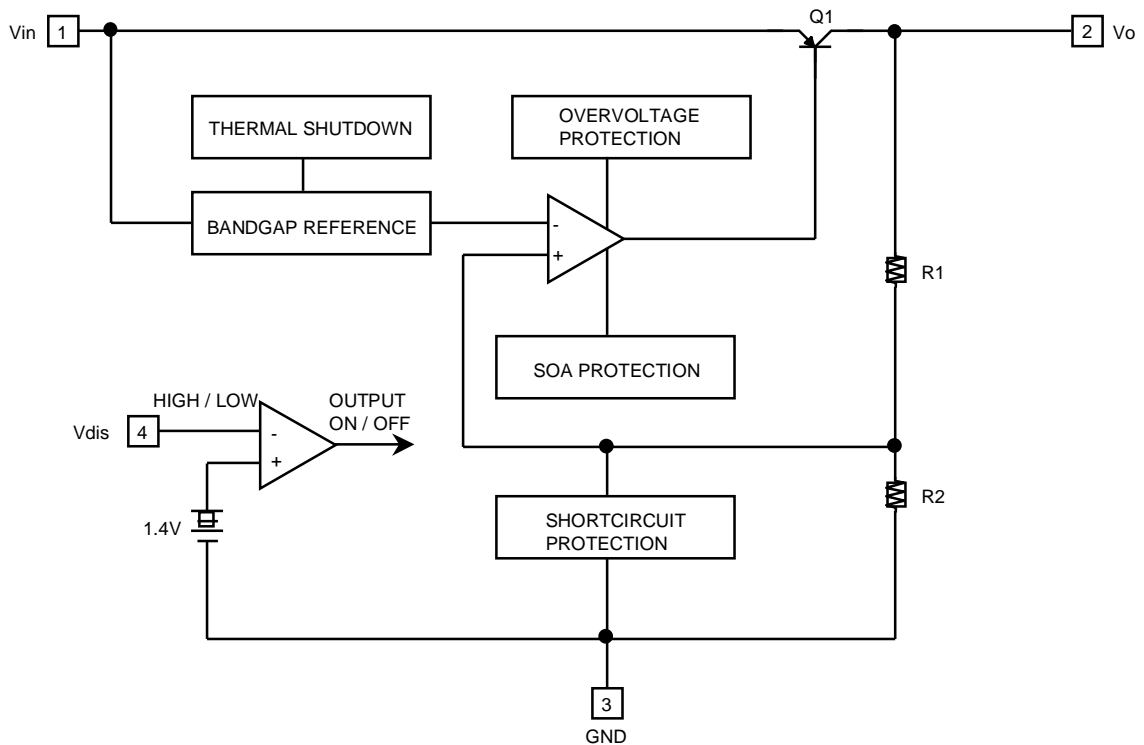

ABSOLUTE MAXIMUM RATINGS

Characteristic	Symbol	Value	Unit	Remark
Input Voltage	V _{in}	35	V	-
Disable Voltage	V _{dis}	35	V	-
Output Current	I _o	1.0	A	-
Power Dissipation 1	P _{d1}	1.5	W	No Heatsink
Power Dissipation 2	P _{d2}	15	W	With Heatsink
Junction Temperature	T _j	150	°C	-
Operating Temperature	T _{opr}	-20 ~ 80	°C	-

ELECTRICAL CHARACTERISTICS(V_{in}=5V, I_o=0.5A, T_a=25°C, unless otherwise specified)

Characteristic	Symbol	Test Condition	Min	Typ	Max	Unit
Output Voltage	V _o	-	3.22	3.3	3.38	V
Load Regulation	R _{load}	5mA < I _o < 1A	-	0.1	2.0	%
Line Regulation	R _{line}	4V < V _{in} < 10V	-	0.5	2.5	%
Ripple Rejection Ratio	RR	note1	45	55	-	dB
Dropout Voltage	V _{drop}	I _o = 1A	-	-	0.5	V
Disable Voltage High	V _{disH}	Output Active	2.0	-	-	V
Disable Voltage Low	V _{disL}	Output Disabled	-	-	0.8	V
Disable Bias Current High	I _{disH}	V _{dis} = 2.7V	-	-	20	μA
Disable Bias Current Low	I _{disL}	V _{dis} = 0.4V	-	-	-0.4	mA
Quiescent Current	I _q	I _o = 0A	-	-	10	mA

*note1 : These parameters, although guaranteed, are not 100% tested in production.

FIG.1 Output Voltage vs. Input Voltage

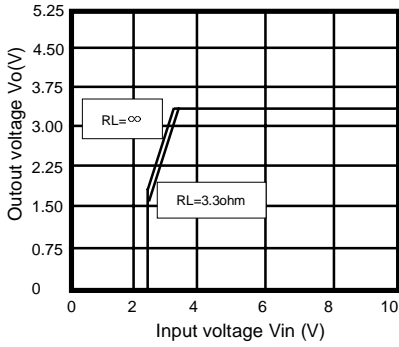

FIG.2 Quiescent Current vs. Input Voltage

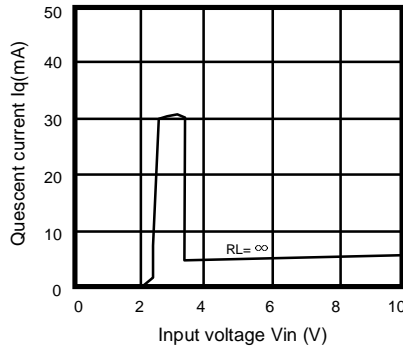

FIG.3 Output Voltage vs. Disable Voltage

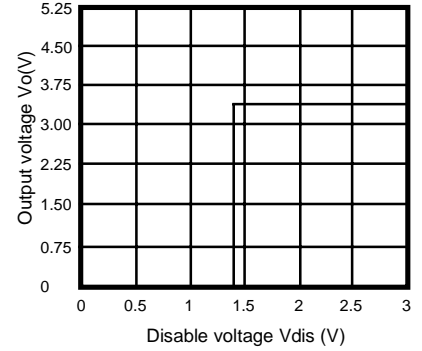

FIG.4 Output Voltage vs. Temperature(Tj)

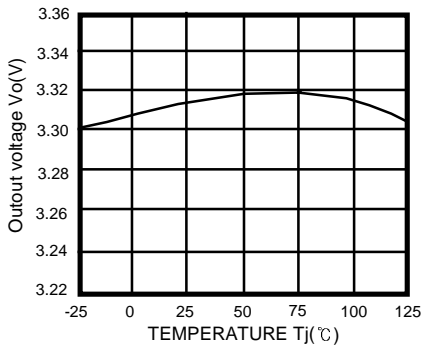

FIG.5 Quiescent Current vs. Temperature(Tj)

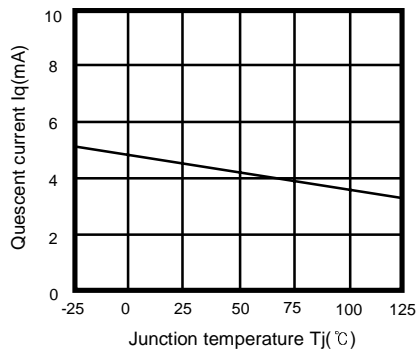

FIG.6 Drop Voltage vs. Disable Voltage

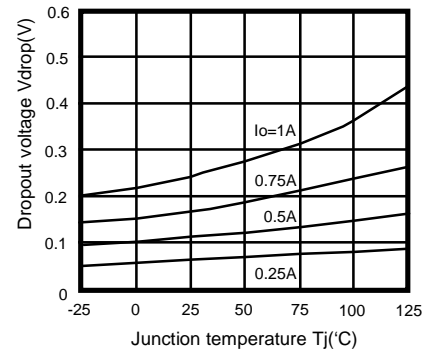
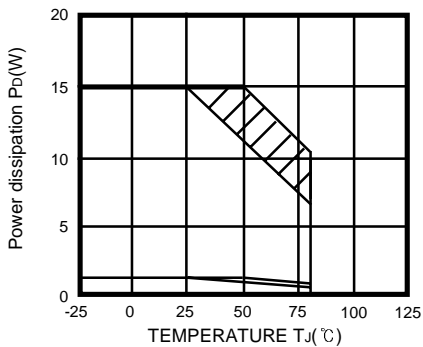
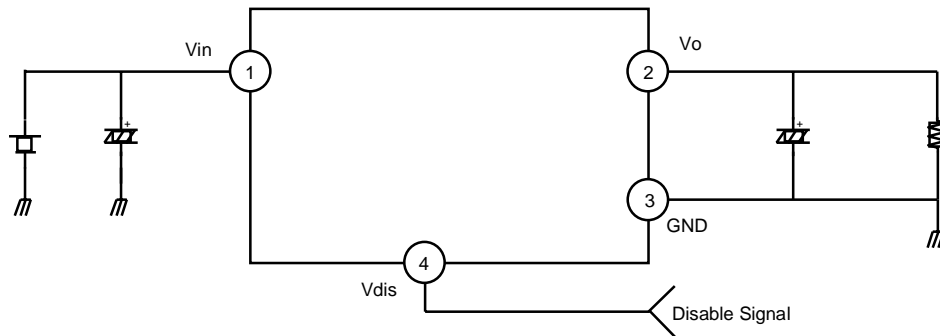

FIG.7 Power Dissipation vs. Temperature(Ta)



TYPICAL APPLICATION

FIG.1 APPLICATION CIRCUIT



- * C_i is required if regulator is located an appreciable distance from power supply filter.
- * C_o improves stability and transient response. ($C_o > 47\mu\text{F}$)

< TO220F-4L >

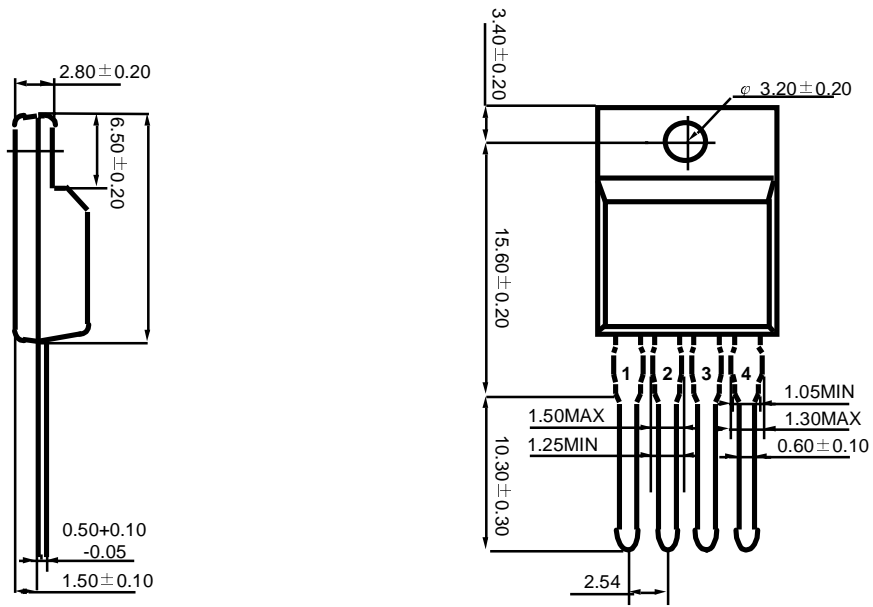

* DIMENSIONS IN MILIMETER