

LOADING MOTOR DRIVER

The KA8330 is a monolithic integrated circuit designed to perform bi-directional DC motor driving, braking and speed control for VCRs, CDPs, and Toys.

The speed control can be achieved by adjusting the external voltage of the motor speed control pin. And it has two pins of logic inputs for controlling the direction such as forward/reverse and braking.

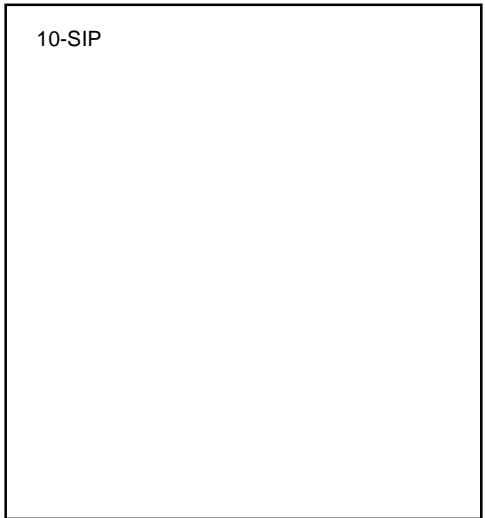

FEATURES

- Stable braking characteristics by built-in braking function
- Built-in element to absorb dash current derived from changing motor direction and braking motor driving
- Built-in external motor speed control pin
- Stable driving direction change
- CMOS logic level compatible input level

TYPICAL APPLICATIONS

- VCR
- CDP
- TOY

ORDERING INFORMATION

Device	Package	Operating Temperature
KA8330	10-SIP	-25°C ~ +75°C

BLOCK DIAGRAM

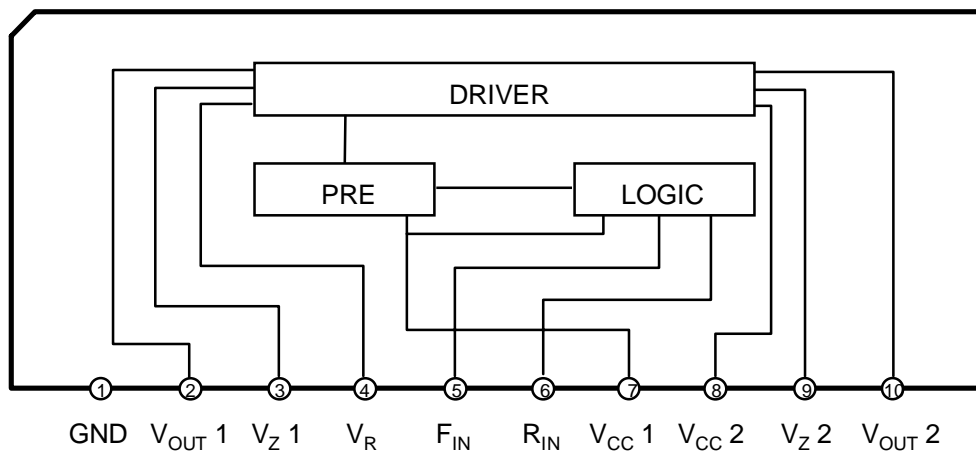

PIN DESCRIPTION

Pin No.	Symbol	I/O	Description
1	GND		Ground
2	V _{OUT 1}	O	Motor drive output 1
3	V _{Z 1}	I	Capacitor connection
4	V _R	I	Motor speed control pin. Zener diode connection.
5	F _{IN}	I	Motor turning direction selection pin. CMOS logic input.
6	R _{IN}	I	Motor turning direction selection pin. CMOS logic input.
7	V _{CC 1}		Power supply pin for IC
8	V _{CC 2}		Power supply pin for driver circuit
9	V _{Z 2}	I	Capacitor connection
10	V _{OUT 2}	O	Motor drive output 2

ABSOLUTE MAXIMUM RATINGS (Note 1 & 2)

Characteristics	Symbol	Value	Unit
Supply Voltage	V_{CC}	18	V
Input Voltage	V_{IN}	-0.3 to V_{CC}	V
Output Current	I_{OUT}	1.6 (Note3)	A
Operating Temperature Range	T_{OPR}	-25 to + 75	°C
Storage Temperature Range	T_{STG}	- 55 to + 125	°C
Power Dissipation	P_D	2.2	W
ESD Susceptibility (Note 4)	V_{ESD}	± 1,500	V

Note 1 : ABSOLUTE MAXIMUM RATINGS are those values beyond which the device may be damaged permanently. Normal operation is not guaranteed at or above these extremes.

Note 2 : All voltages are measured with respect to the GND voltage level unless otherwise specified.

Note 3 : Duty 1/100, pulse width 500 μ s

Note 4 : 100pF discharged through a 1.5k Ω resistor (Human body model).

RECOMMENDED OPERATING CONDITIONS ($T_a = 25\text{ }^\circ\text{C}$)

Characteristics	Symbol	Min	Typ	Max	Unit
Supply Voltage	V_{CC}	8	12	16	V

ELECTRICAL CHARACTERISTICS

(IC Specifications : $V_{CC} = 12\text{V}$, $\text{GND} = 0\text{V}$, $T_a = 25\text{ }^\circ\text{C}$, unless otherwise specified.)

Characteristics	Symbol	Test Conditions	Min	Typ	Max	Unit
Quiescent Current	I_{CCQ}	Pin 5, 6=GND, $R_L = \infty$	3	5.5	10	mA
Minimum Input On Current 1	I_{IN1}	Pin5= I_{IN1} , Pin6=L, $R_L = \infty$		10	50	μ A
Minimum Input On Current 2	I_{IN2}	Pin5=L, Pin6= I_{IN2} , $R_L = \infty$		10	50	μ A
Input Threshold Voltage 1	V_{INTH1}	Pin5= V_{INTH1} , Pin6=L, $R_L = \infty$	0.7	1.3	2.0	V
Input Threshold Voltage 2	V_{INTH2}	Pin5=L, Pin6= V_{INTH2} , $R_L = \infty$	0.7	1.3	2.0	V
Output Leakage Current 1	I_{OL1}	Pin5, 6=GND, $R_L = \infty$			1	mA
Output Leakage Current 2	I_{OL2}	Pin5, 6=GND, $R_L = \infty$			1	mA
Zener Current 1	I_{Z1}	Pin5=H, Pin 6=L, $R_L = \infty$		0.85	1.5	mA
Zener Current 2	I_{Z2}	Pin5=L, Pin 6=H, $R_L = \infty$		0.85	1.5	mA
Output Voltage 1	V_{O1}	Pin5=H, Pin 6=L, $R_L = 60\Omega$	6.6	7.2		V
Output Voltage 2	V_{O2}	Pin5=L, Pin 6=H, $R_L = 60\Omega$	6.6	7.1		V
Saturation Voltage Pin 10-1	V_{CE10-1}	$I_{SINK} = 100\text{mA}$ Pin5=H, Pin 6=L, $R_L, R_C = \infty$		0.83	1.5	V
Saturation Voltage Pin 2-1	V_{CE2-1}	$I_{SINK} = 100\text{mA}$ Pin5=L, Pin 6=H, $R_L, R_C = \infty$		0.83	1.5	V
Saturation Voltage Pin 8-2	V_{CE8-2}	$I_{SOURCE} = 100\text{mA}$ Pin5=H, Pin 6=L, $R_L, R_C = \infty$		0.83	1.5	V
Saturation Voltage Pin 8-10	V_{CE8-10}	$I_{SOURCE} = 100\text{mA}$ Pin5=L, Pin 6=H, $R_L, R_C = \infty$		0.83	1.5	V

Note 5 : Specifications are subject to change without notice.

FUNCTIONAL DESCRIPTION

- Forward & Reverse Control Logic

If F_{IN} (pin 5) = $\overline{0}$? & R_{IN} (pin 6) = 0 ? load current (I_L) flows from V_{OUT1} (pin 2) to V_{OUT2} (pin 10),
 if $F_{IN} = 0$? & $R_{IN} = \overline{0}$? load current (I_L) flows from V_{OUT2} to V_{OUT1} .

- Forced Stop Logic

If F_{IN} & $R_{IN} = \overline{0}$? or 0 ? the device stops supplying power to motor while absorbing inverse electromotive force from the motor as a brake.

- Rush Current Absorbing Circuit

If a high voltage generated during reversing operating is applied across V_{OUT1} & V_{OUT2} , an internal comparator activates the rush-current-absorbing-circuit.

- Driving Stage

In the forward mode, the driving stage supplies a load current to the motor from pin 2 to pin 10. In the reverse mode, it supplies the current from pin 10 to pin 2.

The output voltage V_{OUT} applied to the motor is given by the following method :

$$V_{OUT(V)} = V_{ZD} - V_{CE(SAT)}$$

V_{ZD} : Zener Voltage applied to pin 4.

If pin 4 is left open, the output voltage is given by the following method :

$$V_{OUT(V)} = V_{CC1} - V_{CE(SAT PNP)} - 2V_{BE} - V_{CE(SAT)}$$

TEST CIRCUIT

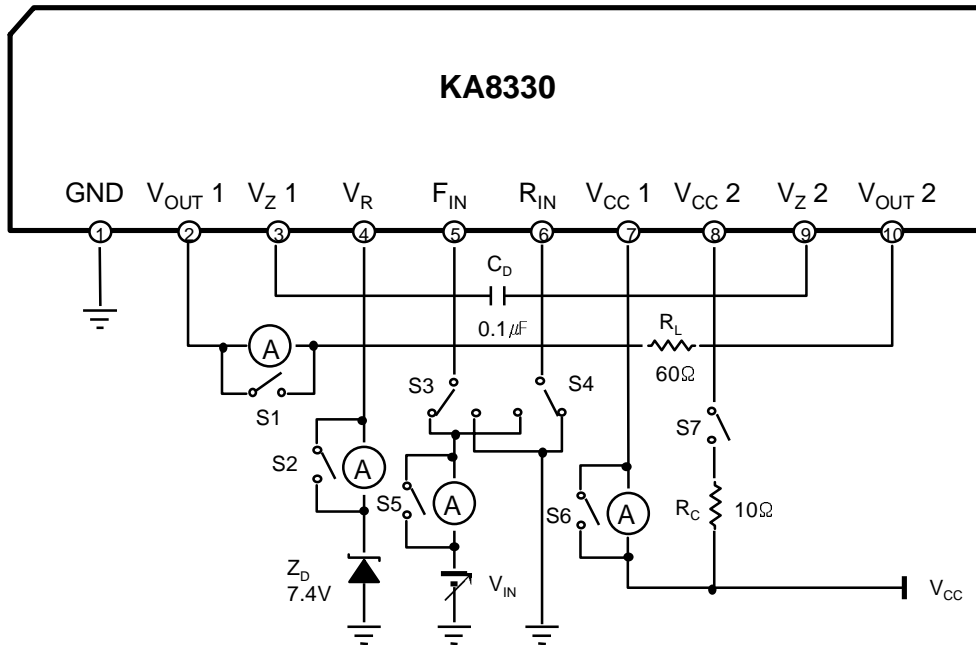

Table 1. Logic Truth Table

F _{IN} (Pin 5)	R _{IN} (Pin 6)	V _{OUT} 1(Pin 2)	V _{OUT} 2 (Pin 10)	Note
L (Note 6)	L	L	L	Braking
L	H	L	H	Reverse
H	L	H	L	Forward
H	H	L	L	Braking

Note 6 : Input Level $\text{믹?} > 2.0V$
 Input Level $\text{땡?} < 0.7V$

Note 7 : Under any condition, to prevent malfunction, note that V_{CC} 2 (pin 8) should not be open(off) later than V_{CC} 1(pin 7) after turning on V_{CC} 1 and V_{CC} 2 . Anytime V_{CC} 1 and V_{CC} 2 are always on/off together.

The following is a case of the fatal damage to KA8330:

SW1	SW2	SW3	SW4	SW5	SW6	SW7
ON/OFF	OFF	H	L	ON	ON	ON→OFF ON→OFF→ON

TYPICAL APPLICATION (6V Motor Connection)

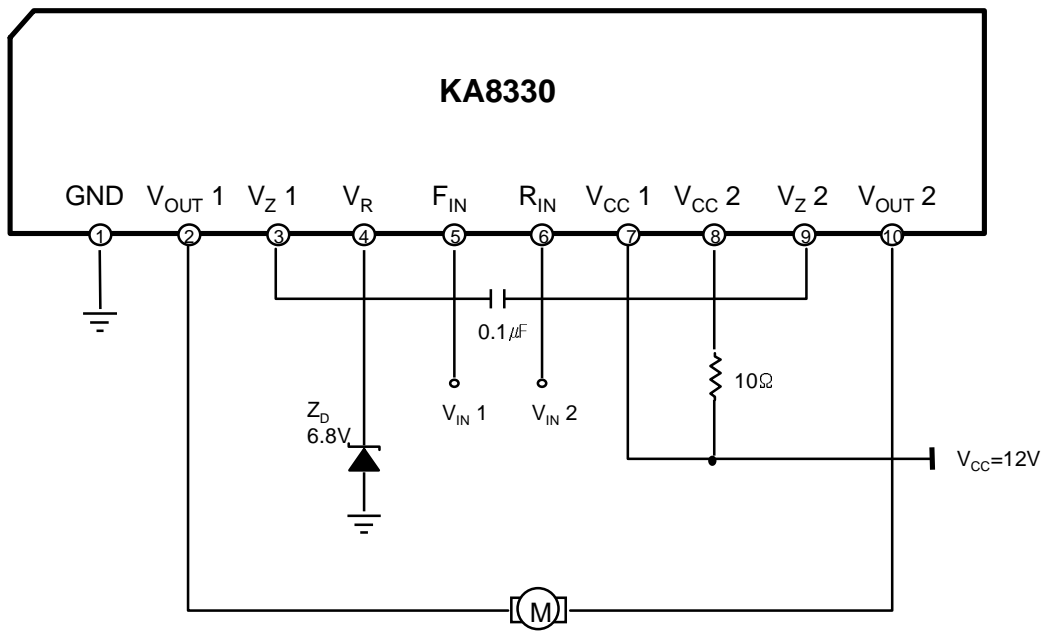

10-SIP

Dimensions in Millimeters/Inches

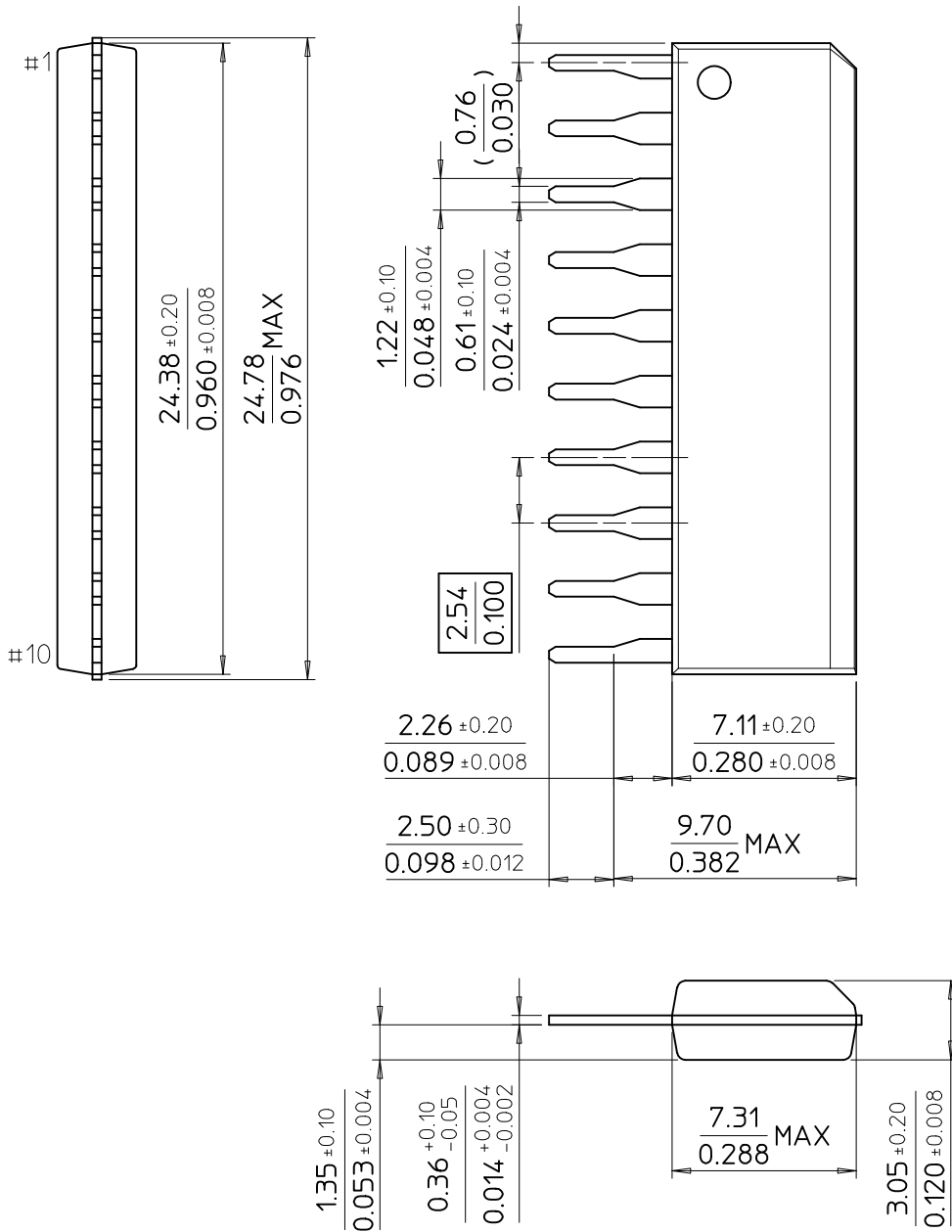

SAMSUNG ELECTRONICS CO.,LTD.