

5-CH MOTOR DRIVER

The KA9260D is a monolithic integrated circuit, and suitable for 5-ch motor driver which drives focus actuator, tracking actuator, sled motor, spindle motor and loading motor of CD system.

FEATURES

- 1 phase, full-wave, linear DC motor driver
- Built-in TSD (Thermal shutdown) circuit
- Built-in 5V regulator (With an external PNP TR)
- Built-in mute circuit
- Built-in loading motor speed control circuit
- Wide operating supply voltage range: 6V~13.2V

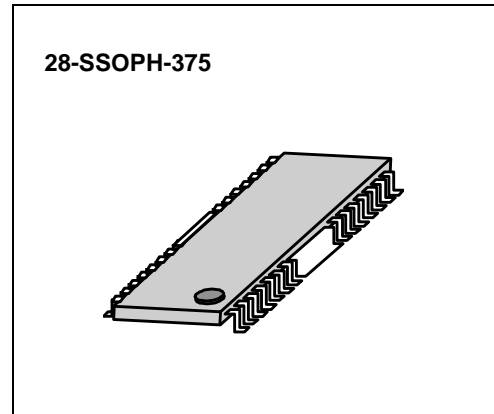

ORDERING INFORMATION

Device	Package	Operating Temperature
KA9260D	28-SSOPH-375	-25°C ~ +75°C

TARGET APPLICATION

- CD-PLAYER
- VIDEO-CD
- CAR-CDBLOCK DIAGRAM

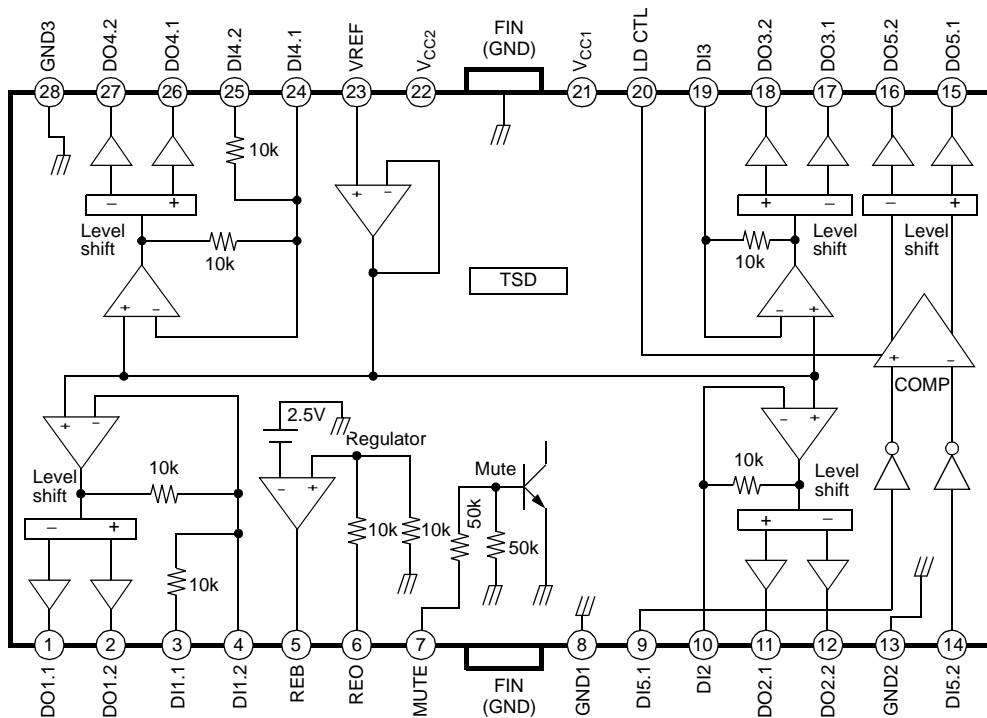

PIN CONFIGURATION

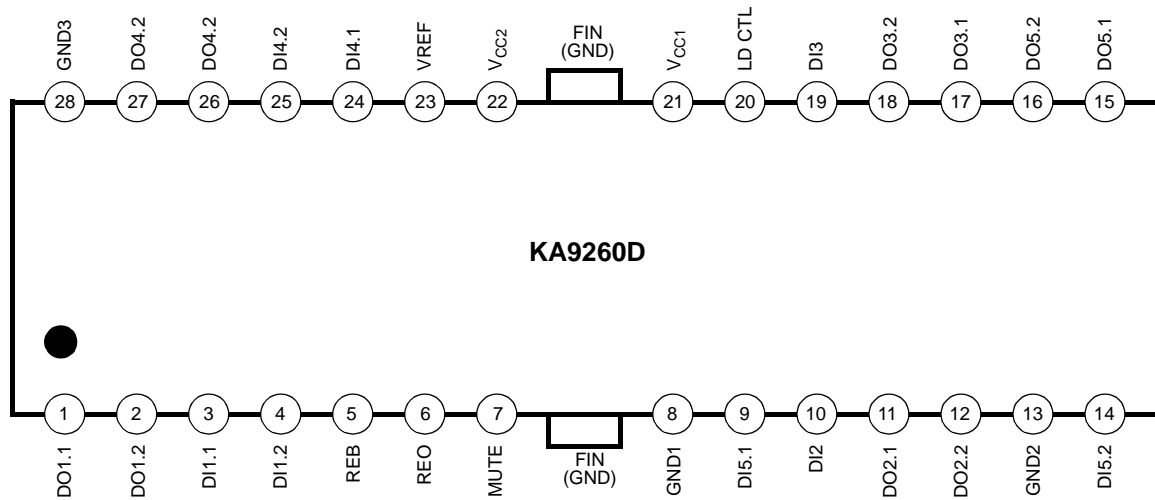

PIN DESCRIPTION

Pin No.	Symbol	I/O	Description	Pin No.	Symbol	I/O	Description
1	DO1.1	O	Focus output 1 (-)	15	DO5.1	O	Loading output (+)
2	DO1.2	O	Focus output 2 (+)	16	DO5.2	O	Loading output (-)
3	DI1.1	I	Focus input 1	17	DO3.1	O	Sled output (-)
4	DI1.2	I	Focus input 2 (Adjustable)	18	DO3.2	O	Sled output (+)
5	REB	O	Regulator base	19	DI3	I	Sled input
6	REO	O	Regulator output, 5V	20	LD CTL	I	Loading motor speed control
7	MUTE	I	Mute	21	V _{CC1}	-	Supply voltage 1
8	GND1	-	Ground 1	22	V _{CC2}	-	Supply voltage 2
9	DI5.1	I	Loading input 1	23	VREF	I	2.5V bias
10	DI2	I	Spindle input 2	24	DI4.1	I	Tracking input 1 (Adjustable)
11	DO2.1	O	Spindle output (+)	25	DI4.2	I	Tracking input 2
12	DO2.2	O	Spindle output (-)	26	DO4.1	O	Tracking output 1 (+)
13	GND2	-	Ground 2	27	DO4.2	O	Tracking output 2 (-)
14	DI5.2	I	Loading input 2	28	GND3	-	Ground 3

EQUIVALENT CIRCUITS

Driver input (Except for loading motor driver)	Driver output
Loading motor driver input	Loading motor speed control input
Mute input	Bias input
Drive input	

ABSOLUTE MAXIMUM RATING (Ta=25°C)

Characteristics	Symbol	Value	Unit
Maximum supply voltage	$V_{CC\ MAX}$	18	V
Power dissipation	P_D	@1.7	W
Operating temperature	T_{OPR}	-25 ~ +75	°C
Storage temperature	T_{STG}	-55 ~ +150	°C
Maximum current output	I_{OMAX}	1	A

NOTE: @

1. When mounted on 76mm × 114mm × 1.57mm PCB (Phenolic resin material).
2. Power dissipation reduces 13.6mW / °C for using above Ta=25°C.
3. Do not exceed Pd and SOA.

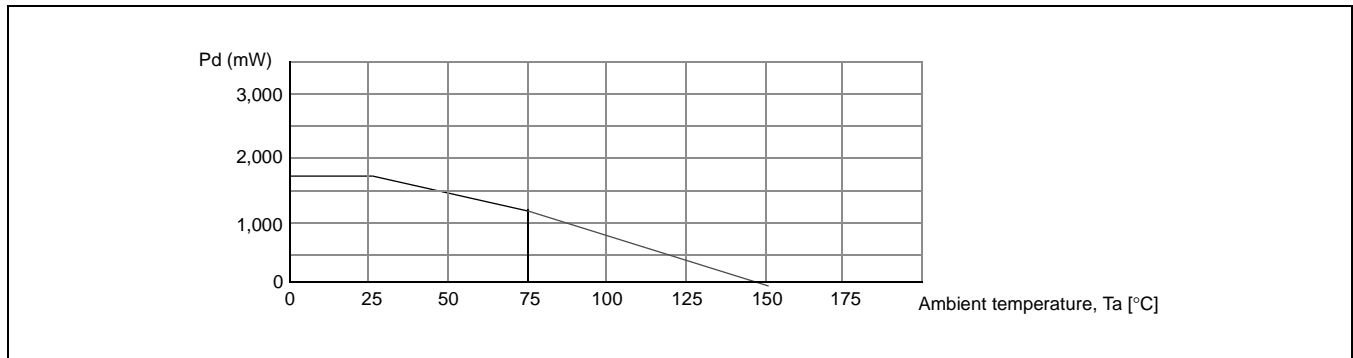
**RECOMMENDED OPERATING CONDITION (TA=25°C)**

Characteristics	Symbol	Value	Unit
Operating supply voltage	V_{CC}	6 ~ 13.2	V

ELECTRICAL CHARACTERISTICS

(Ta=25°C, V_{CC}=8V, R_L=8Ω, f=1kHz, unless otherwise specified)

Characteristic	Symbol	Test conditions	Min.	Typ.	Max.	Unit
Quiescent circuit current	I _{CCQ}	Under no-load	7	10	13	mA
Mute-on current	I _{MUTE}	Pin 7=GND	–	4	7	mA
Mute-on voltage	V _{MON}	–	0	–	0.5	V
Mute-off voltage	V _{MOFF}	–	2	–	–	V
REGULATOR PART						
Output voltage	V _{REG}	I _L =100mA	4.7	5.0	5.3	V
Load regulation	ΔV _{RL3}	I _L =0→200mA	–50	0	50	mV
Line regulation	ΔV _{CC}	V _{CC} =6→13V, I _L =100mA	–20	0	80	mV
DRIVER PART (Except for loading motor driver)						
Input offset voltage	V _{IO}	–	–15	–	15	mV
Output offset voltage 1	V _{OO1}	–	–40	–	40	mV
Maximum source current 1	I _{SOURCE1}	R _L =8Ω→V _{CC}	0.25	0.4	–	A
Maximum sink current 1	I _{SINK1}	R _L =8Ω→GND	0.25	0.4	–	A
Maximum output voltage 1	V _{OM1}	V _{IN} =0.7V	2.5	3.3	–	V
Maximum output voltage 2	V _{OM2}	V _{IN} =7V	–	–4.5	–3.7	V
Closed-loop voltage gain 1	A _{VF1}	V _{IN} =0.1V _{RMS}	5	6.5	8	dB
Closed-loop voltage gain 2	A _{VF2}	V _{IN} =1V _{RMS} , R _{IN} =10kΩ	5	6.5	8	dB
Ripple rejection ratio	RR	V _{IN} =0.1V _{RMS} , f=120Hz	40	60	–	dB
Slew rate	SR	120Hz, V _{IN} =1V _{RMS} , Square wave	1	2	–	V / μs
LOADING MOTOR DRIVER PART (Unless otherwise specified, V_{CTL}=opened)						
Output voltage 1	V _{O1}	V _{PIN9} =5V, V _{PIN14} =0V, R _L =45Ω	2.5	3.1	3.8	V
Output voltage 2	V _{O2}	V _{PIN9} =0V, V _{PIN14} =5V, R _L =45Ω	2.5	3.1	3.8	V
Output voltage regulation 1 (CTL)	V _{OCTL1}	V _{CTL} =3.5→4.5V, V _{PIN9} =5V V _{PIN14} =0V, R _L =45Ω	0.5	1.0	1.5	V
Output voltage regulation 2 (CTL)	V _{OCTL2}	V _{CTL} =3.5→4.5V, V _{PIN9} =0V V _{PIN14} =5V, R _L =45Ω	0.5	1.0	1.5	V
Load regulation 1	ΔV _{RL1}	I _L =100→400mA, V _{PIN9} =5V, V _{PIN14} =0V	–	300	700	mV
Load regulation 2	ΔV _{RL2}	I _L =100→400mA, V _{PIN9} =0V, V _{PIN14} =5V	–	300	700	mV
Output offset voltage 2	V _{OO2}	V _{PIN9} =5V, V _{PIN14} =5V	–40	–	40	mV
Output offset voltage 3	V _{OO3}	V _{PIN9} =0V, V _{PIN14} =0V	–40	–	40	mV

APPLICATION INFORMATION

1. MUTE

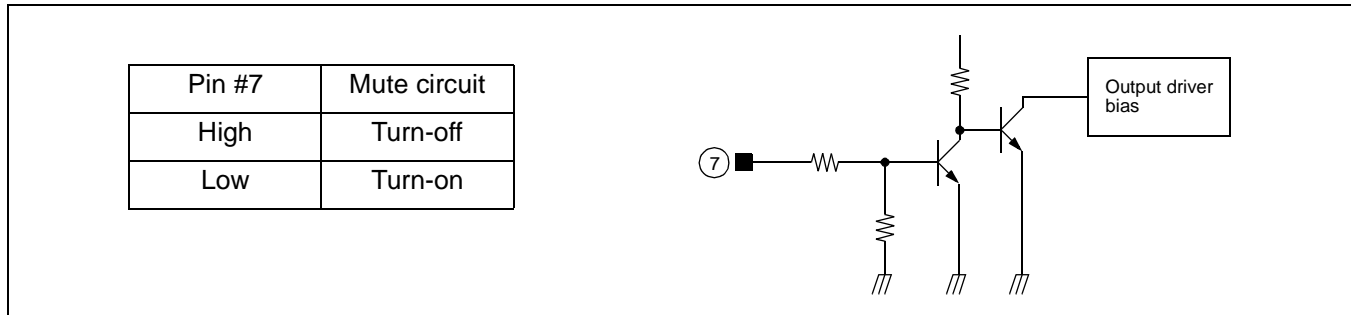

- When the mute pin #7 is open or the voltage of the mute pin #7 is below 0.5V, the mute circuit is activated so that the output circuit will be muted.
- When the voltage of the mute pin is above 2V, the mute circuit is stopped and the output circuit is operated normally.
- If the chip temperature rises above 175°C, then the TSD (Thermal Shutdown) circuit is activated and the output circuit is muted.

2. TSD (THERMAL SHUTDOWN)

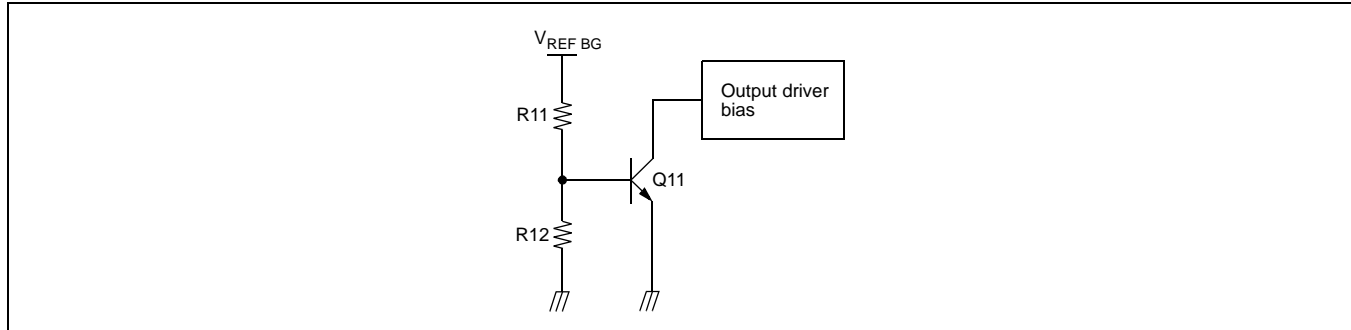

- The $V_{REF\ BG}$ is the output voltage of the band-gap-referenced biasing circuit and acts as the input voltage of the TSD circuit.
- The base-emitter voltage of the TR, Q11 is designed to turn-on at below voltage.

$$V_{BE} = V_{REF\ BG} \times R12 / (R11 + R12) = 400mV$$
- When the chip temperature rises up to 175°C, then the turn-on voltage of the Q11 would drop down to 400mV. Hence, the Q11 would turn on so the output circuit will be muted.

3. REGULATOR

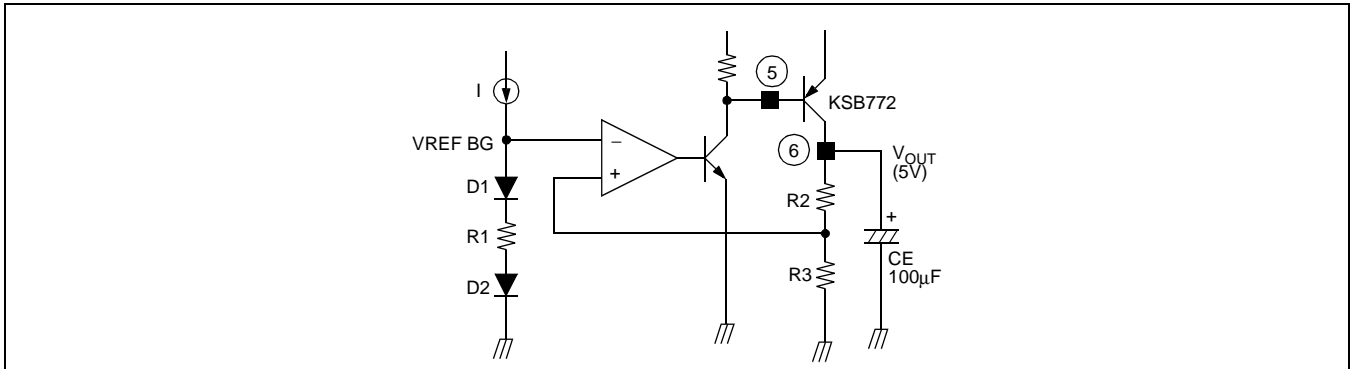

- The $V_{REF\ BG}$ is the output voltage of the band-gap-referenced biasing circuit and is the reference voltage of the regulator.
- The external circuit is composed of the transistor, KSB772 and a capacitor, 100µF, and the capacitor is used as a ripple eliminator and should have a good temperature characteristics.
- The output voltage, V_{OUT} is decided as follows.

$$V_{OUT} = V_{REF\ BG} \times 2 = 2.5 \times 2 = 5V \text{ (R2 = R3)}$$
 where, the $V_{REF\ BG} = V_{D1} + V_{D2} + (I \times R1)$
 $R2=R3$

4. LOADING MOTOR DRIVER

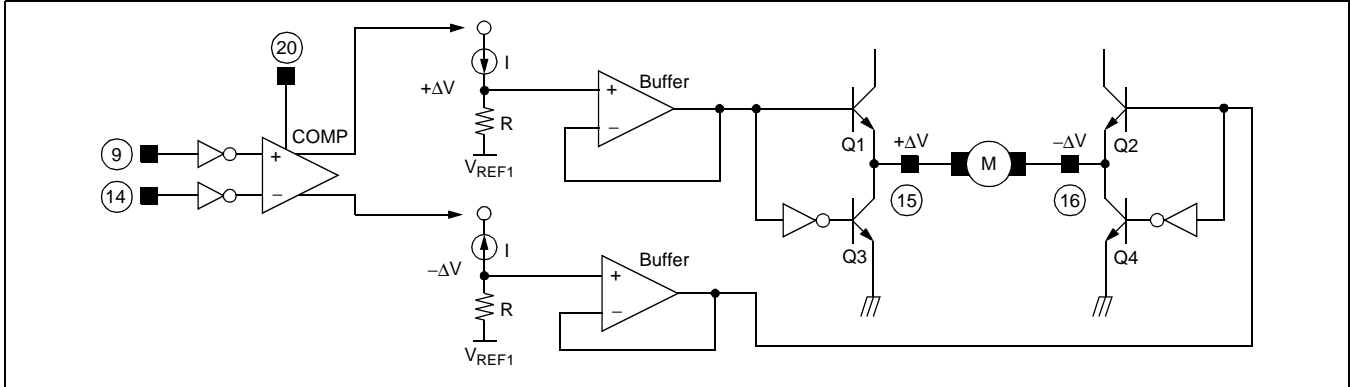

- The input voltages of (5V and 0V) or (0V and 5V) pairs are applied to the input pin #9 and #14 respectively.
- When the input voltages are applied to the input pin #9 and #14, then the output of the comparator is decided depends on the input voltage status.
- As shown in the above diagram, the difference ΔV , $[V_{REF1} + (I \times R)] - [V_{REF1} - (I \times R)]$, is applied to the both terminals of the motor. The direction of the motor is decided by the voltage difference, $+\Delta V$ and $-\Delta V$.
- The output characteristics is as follows,
 - If pin # 9=5V and #14=0V, then pin # 15= $+\Delta V$ and #16= $-\Delta V$, hence the motor turn in forward direction.
 - If pin # 9=0V and #14=5V, then pin # 15= $-\Delta V$ and #16= $+\Delta V$, hence the motor turn in reverse direction.
 - If pin # 9=5V and #14=5V, then $\Delta V=0V$, hence the motor stop.
 - If pin # 9=0V and #14=0V, then $\Delta V=0V$, hence the motor stop.
- When the rotation speed control of the loading motor is desired, refer to the follows.

5. LOADING MOTOR SPEED CONTROL

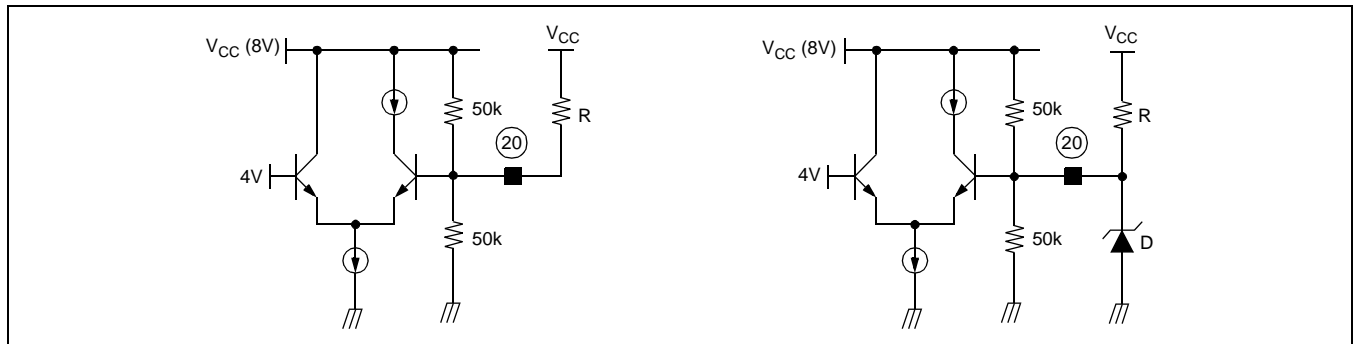

- If the torque of the loading motor is too low when it is used with the pin #20 OPEN, then it should be used as the above diagram.
- The desired torque could be obtained by selecting the appropriate resistor R as shown in the left diagram.
- If it is necessary, the zener diode can be used as in the right diagram.
- The maximum torque is obtained when the applied voltage at pin #20 is about 6.8V (at $V_{CC}=8V$).

6. DRIVER (EXCEPT FOR LOADING MOTOR DRIVER)

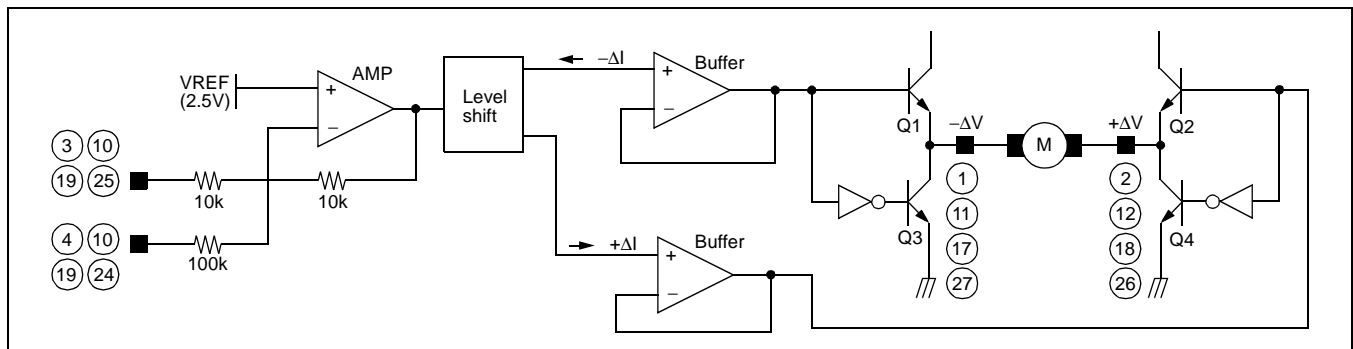

- The voltage, V_{REF} , is the reference voltage given by the bias voltage of the pin #23.
- The input signal through the pin #3 is amplified by 10k/10k times and then fed to the level shift.
- The level shift produces the current due to the difference between the input signal and the arbitrary reference signal. The current produced as $+\Delta I$ and $-\Delta I$ is fed into the driver buffer.
- Driver buffer operates the power TR of the output stage according to the state of the input signal.
- The output stage is the BTL driver and the motor is rotating in forward direction by operating TR Q1 and TR Q4. On the other hand, if TR Q2 and TR Q3 is operating, the motor is rotating in reverse direction.
- When the input voltage through the pin #3 is below the V_{REF} , then the direction of the motor is forward direction.
- When the input voltage through the pin #3 is above the V_{REF} , then the direction of the motor is reverse direction.

7. When the bias voltage of the pin #23 is below 1.4V, then the output circuit will be muted.
Hence for the normal operation, the bias voltage should be used in 1.6V~6.5V.
8. Connect a by-pass capacitor, 0.1 μ F between the supply voltage source.

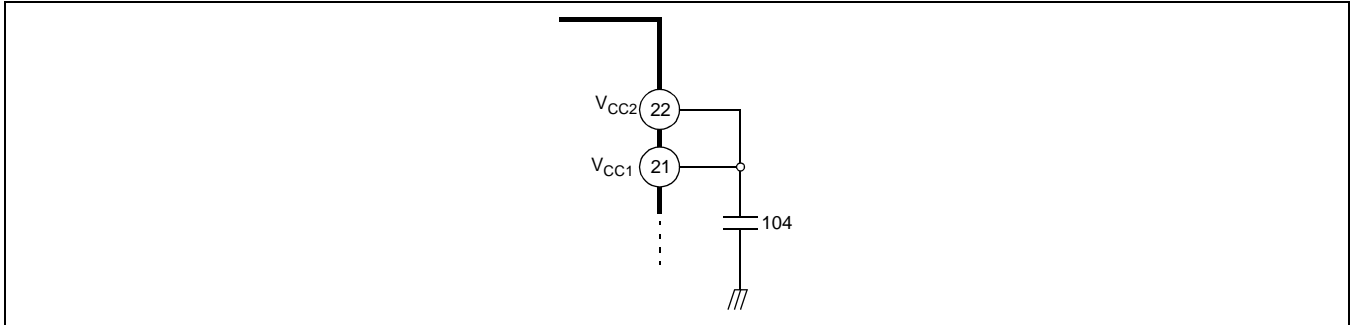

9. Radiation fin is connecting to the internal GND of the package.
Connect the fin to the external GND.

ELECTRICAL CHARACTERISTICS CURVES

Vcc vs. Icc

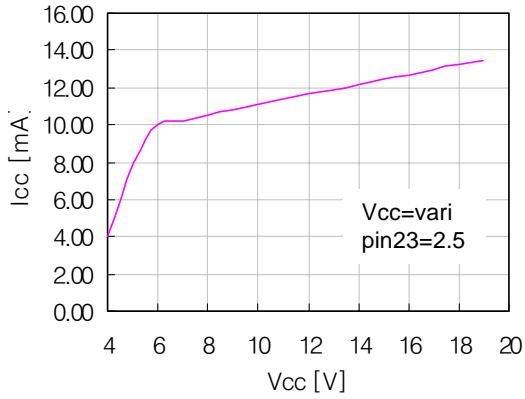

Vcc vs. Imute

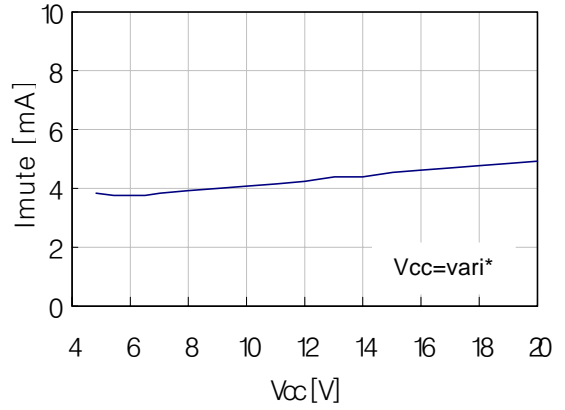

Vcc vs. Isou

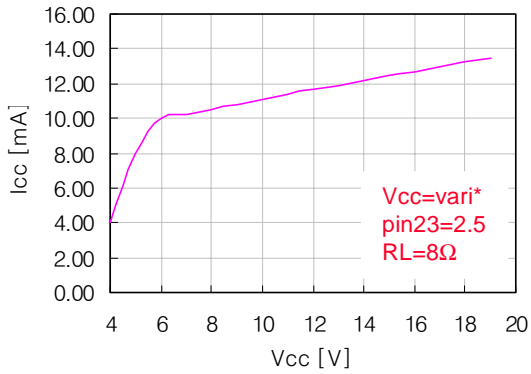

Vcc vs. Isink

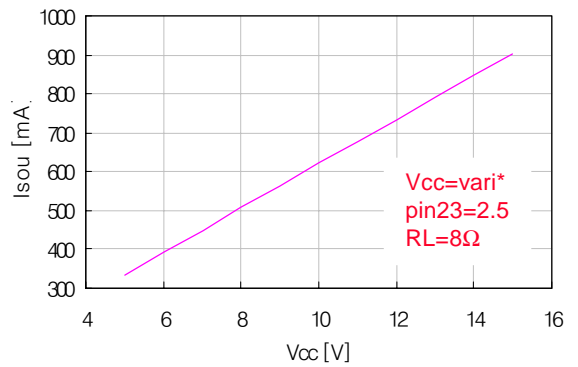

Vcc vs. Avf1

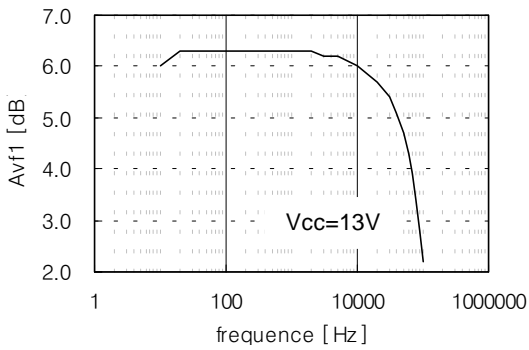

frequency vs. Avf1

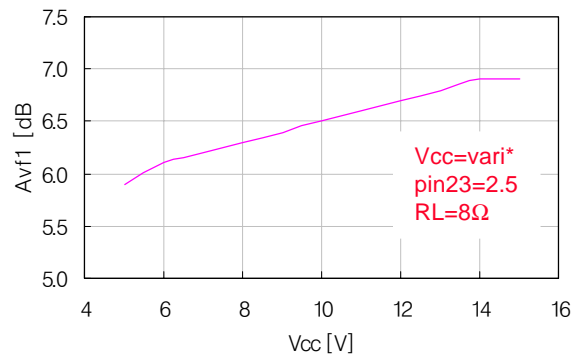

ELECTRICAL CHARACTERISTICS CURVES(CONTINUED)

Vcc vs. Vreg

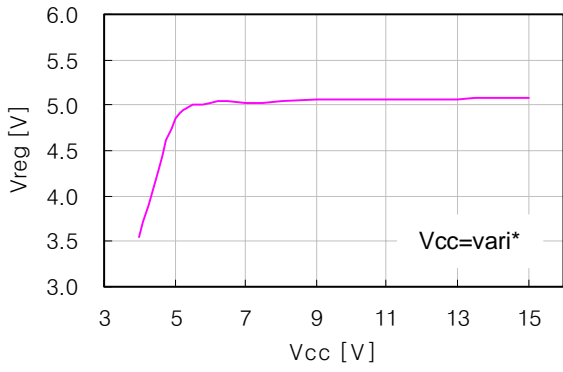

Vcc vs. Vom1

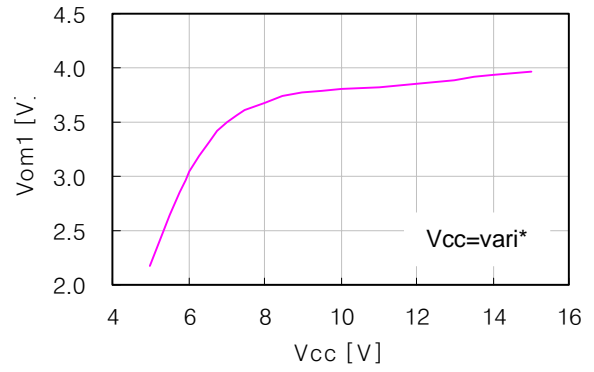

TEST CIRCUIT

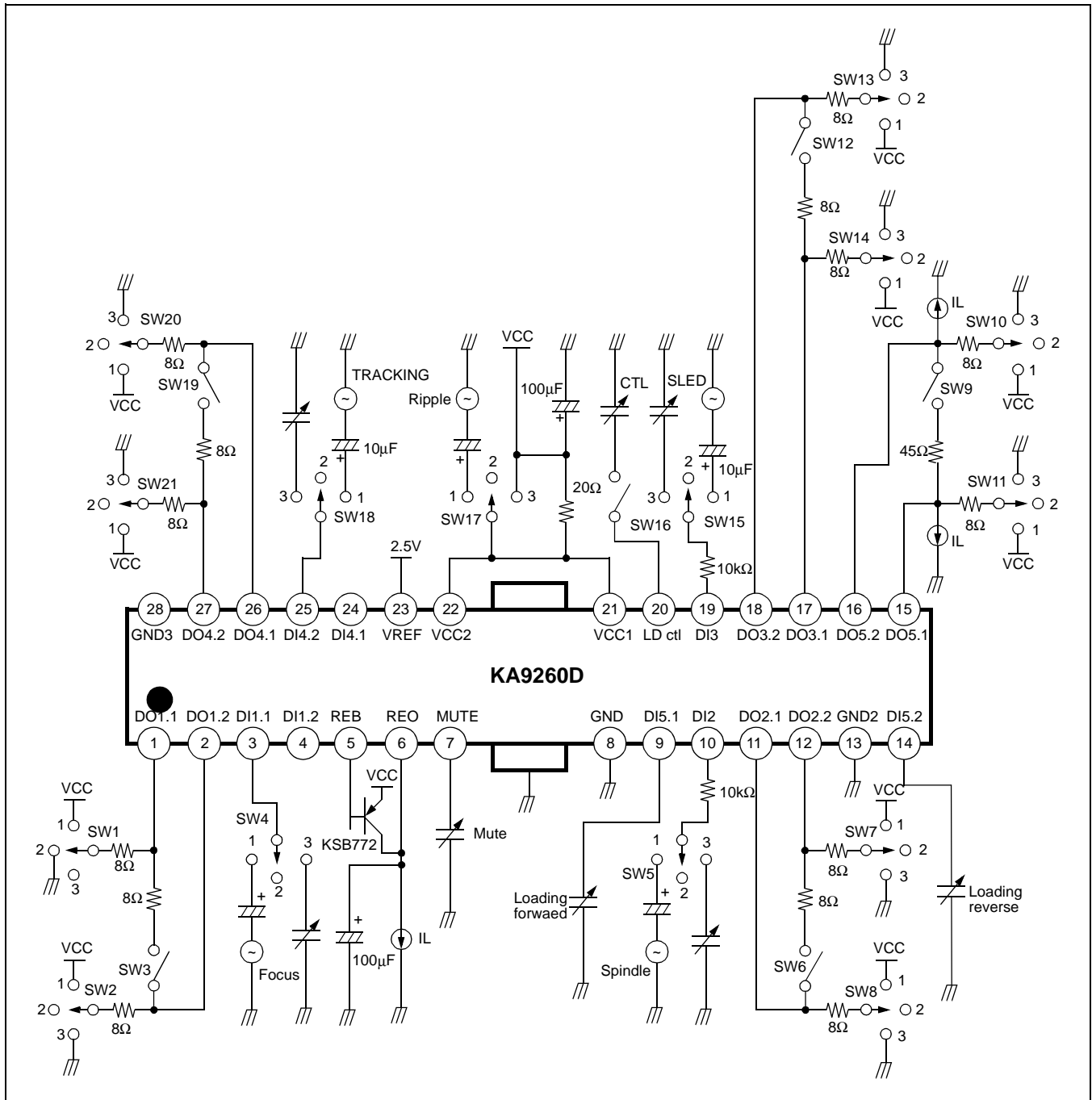

APPLICATION CIRCUIT

