

**INTRODUCTION**

The KC73125-M is an interline transfer CCD area image sensor developed for EIA 1/3inch video cameras. it can be used for door phone, surveillance camera, object detection and pattern recognition.

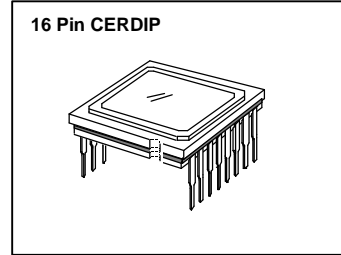

**FEATURES**

- High Sensitivity
- Optical Size 1/3inch Format
- Variable Speed Electronic Shutter
- Low Dark Current
- High antiblooming
- Low Smear
- Horizontal Register 5V Drive
- 16pin Ceramic DIP Package
- Field Integration Read Out System

**ORDERING INFORMATION**

Device	Package	Operating Temperature
KC73125-M	16pin CERDIP	-10°C ~ + 50°C

**STRUCTURE**

- Number of total pixels : 537 (H) × 505 (V)
- Number of effective pixels : 510 (H) × 492 (V)
- Chip size : 5.90mm(H) × 5.10mm(V)
- Unit pixel size : 9.60µm(H) × 7.50µm(V)
- Optical blacks & dummies : Refer from below figure

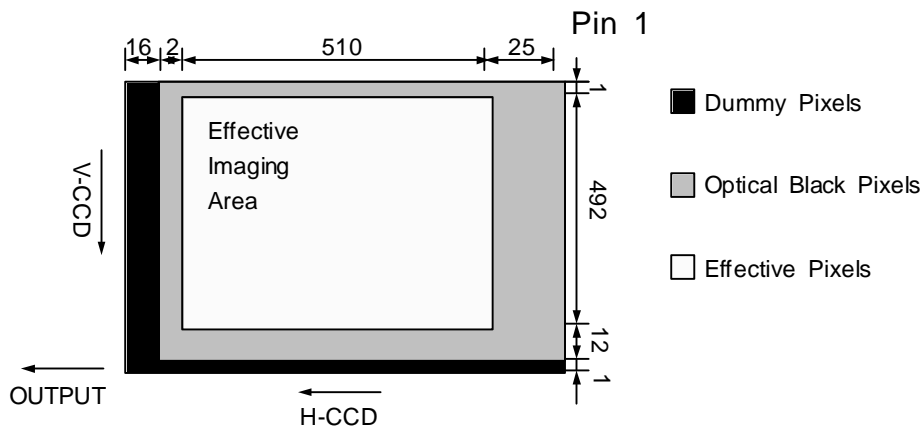

BLOCK DIAGRAM

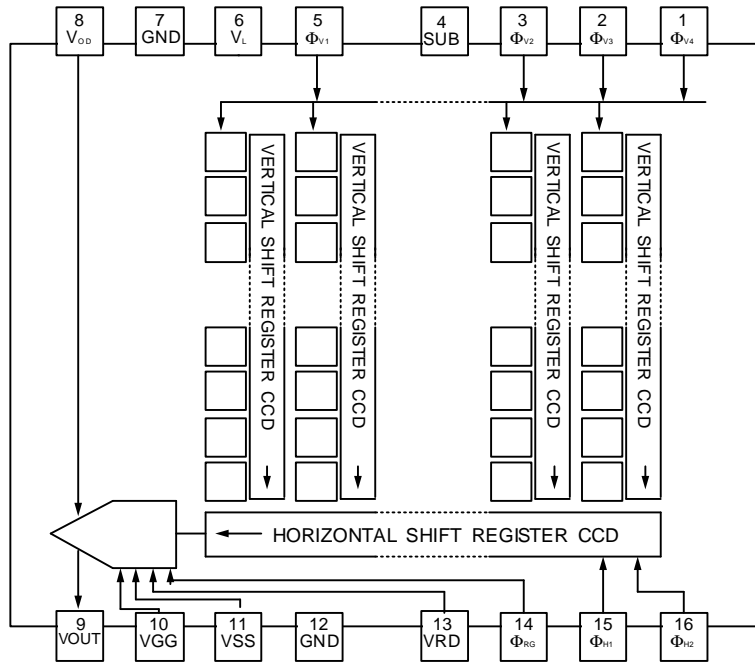

PIN DESCRIPTION

Pin	Symbol	Description	Pin	Symbol	Description
1	$\Phi_{V4}$	Vertical CCD Transfer Clock 4	9	VOUT	Signal Output
2	$\Phi_{V3}$	Vertical CCD Transfer Clock 3	10	VGG	Output AMP Gate Voltage
3	$\Phi_{V2}$	Vertical CCD Transfer Clock 2	11	VSS	Output AMP Source Voltage
4	SUB	Substrate Voltage	12	GND	Ground
5	$\Phi_{V1}$	Vertical CCD Transfer Clock 1	13	VRD	Reset Drain Voltage
6	$V_L$	Protective Bias Voltage	14	$\Phi_{RG}$	Charge Reset Clock
7	GND	Ground	15	$\Phi_{H1}$	Horizontal CCD Transfer Clock 1
8	VOD	Output AMP drain Voltage	16	$\Phi_{H2}$	Horizontal CCD Transfer Clock 2



**ABSOLUTE MAXIMUM RATINGS** <sup>\*(1)</sup>

Characteristics	Symbols	Min.	Max.	Unit
Substrate Voltage	SUB-GND	-0.3	55	V
Supply Voltage	V <sub>DD</sub> , V <sub>OUT</sub> , V <sub>SS</sub> -GND	-0.3	17	V
Vertical Clock Input Voltage	Φ <sub>V1</sub> , Φ <sub>V2</sub> , Φ <sub>V3</sub> , Φ <sub>V4</sub> -GND	-10	20	V
	Φ <sub>V1</sub> , Φ <sub>V2</sub> , Φ <sub>V3</sub> , Φ <sub>V4</sub> -V <sub>L</sub>	-0.3	30	V
Horizontal Clock Input Voltage	Φ <sub>H1</sub> , Φ <sub>H2</sub> - GND	-0.3	17	V
Voltage Difference between Vertical and Horizontal Clock Input Pins	Φ <sub>V1</sub> , Φ <sub>V2</sub> , Φ <sub>V3</sub> , Φ <sub>V4</sub>	-20	20	V
	Φ <sub>H1</sub> , Φ <sub>H2</sub>	-17	17	V
	Φ <sub>H1</sub> , Φ <sub>H2</sub> - Φ <sub>V4</sub>	-17	17	V
Output Clock	Φ <sub>RG</sub> , V <sub>GG</sub> - GND	-0.3	17	V
Protection Circuit Bias Voltage	V <sub>L</sub> - SUB	-65	0.3	V
Operating Temperature	T <sub>OPR</sub>	-10	50	°C
Storage Temperature	T <sub>STG</sub>	-30	80	°C

\* (1) The device can be destroyed, if the applied voltage or temperature is higher than the absolute maximum rating voltage or temperature.

**DC CONDITIONS**

Item	Symbol	Min.	Typ.	Max.	Unit	Remark
Output Stage Drain Bias	V <sub>DD</sub>	14.55	15.0	15.45	V	
Output Stage Gate Voltage	V <sub>GG</sub>	1.75	2.0	2.25	V	
Output Stage Source Voltage	V <sub>SS</sub>	Ground through 680Ω			V	±5%
Substrate Voltage Adjustment Range	V <sub>SUB</sub>	8.0		19.0	V	
Fluctuation Voltage Range after Substrate Voltage Adjusted	ΔV <sub>SUB</sub>	-3		3	%	
Reset Gate Voltage Adjustment Range	V <sub>RGL</sub>	1.0	2.0	4.0	V	
Fluctuation Voltage Range after Reset Gate Voltage Adjusted	ΔV <sub>RGL</sub>	-3		3	%	
Protection Circuit Bias Voltage	V <sub>L</sub>	V <sub>L</sub> voltage of the vertical clock waveform				
Output Stage Drain Current	I <sub>DD</sub>		2.5		mA	

**CLOCK VOLTAGE CONDITIONS**

Item	Symbol	Min.	Typ.	Max.	Unit	Remark
Read-out Clock Voltage	V <sub>VT</sub>	14.55	15.0	15.45	V	High level
Vertical Transfer Clock Voltage	V <sub>VH1</sub> ~V <sub>VH4</sub>	-0.05	0.0	0.05	V	V <sub>VH</sub> =(V <sub>VH1</sub> +V <sub>VH2</sub> )/2
	V <sub>VL1</sub> ~V <sub>VL4</sub>	-9.0	-8.5	-8.0	V	V <sub>VL</sub> =(V <sub>VL3</sub> +V <sub>VL4</sub> )/2
Horizontal Transfer Clock Voltage	V <sub>oH</sub>	4.75	5.0	5.25	V	High
	V <sub>oHL</sub>	-0.05	0.0	0.05	V	Low
Charge Reset Clock Voltage	V <sub>oRG</sub>	4.75	5.0	5.25	V	High
	V <sub>RGLH</sub> ~V <sub>RGLL</sub>			0.8	V	Low
Substrate Clock Voltage	V <sub>oSUB</sub>	20.0	23.5	25.0	V	Shutter



DRIVE CLOCK WAVEFORM CONDITIONS

(1) Read out clock waveform

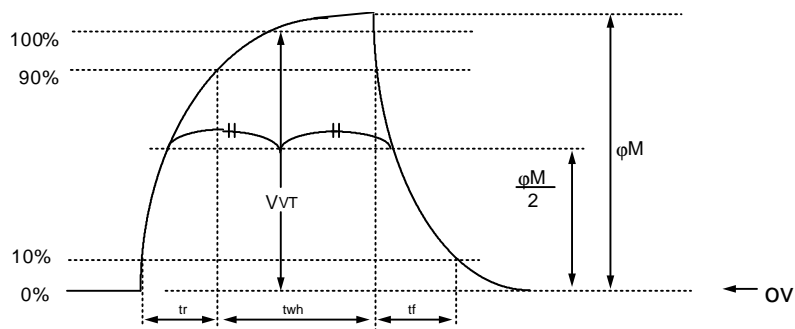

(2) Vertical transfer clock waveform

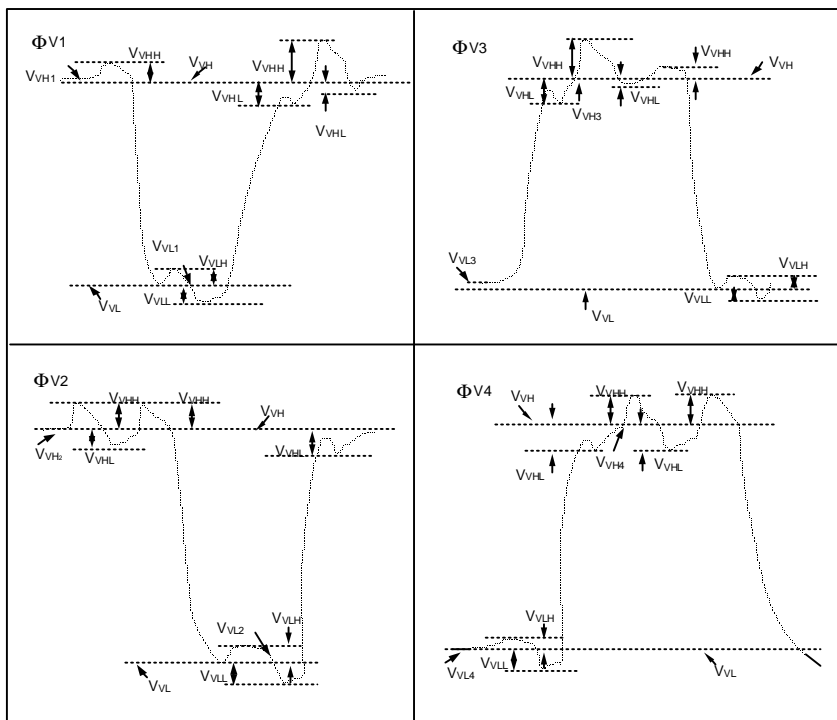

(3) Horizontal transfer clock waveform diagram

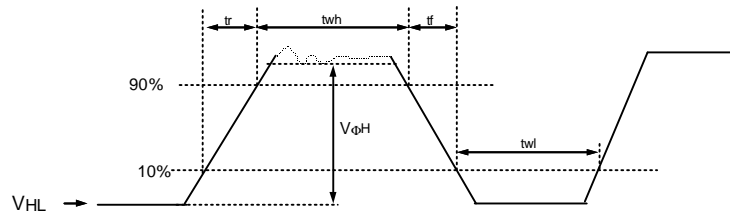

(4) Reset gate clock waveform diagram

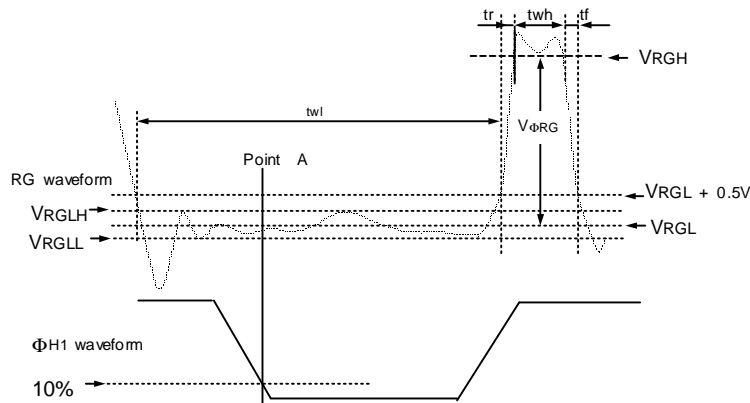

$V_{RGLH}$  is the maximum value and  $V_{RGL}$  the minimum value of the coupling waveform in the period from Point A in the diagram about to RG rise

$$V_{RGL} = (V_{RGLH} + V_{RGLL}) / 2, \quad V_{\phi RG} = V_{RGLH} - V_{RGL}$$

(5) Substrate clock waveform

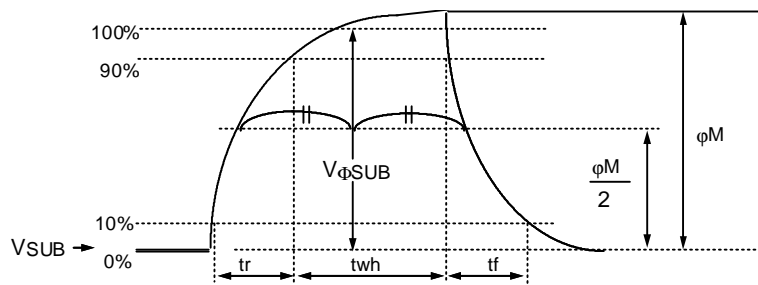

CLOCK EQUIVALENT CIRCUIT CONSTANT

Item	Symbol	Typ.	Unit	Remark
Capacitance between Vertical Transfer Clock and GND	$C_{\phi V1}, C_{\phi V3}$	1,300	pF	
	$C_{\phi V2}, C_{\phi V4}$	1,300	pF	
Capacitance between Vertical Transfer Clocks	$C_{\phi V12}, C_{\phi V34}$	600	pF	
	$C_{\phi V23}, C_{\phi V41}$	230	pF	
	$C_{\phi V13}$	120	pF	
	$C_{\phi V24}$	90	pF	
Capacitance between Horizontal Transfer Clock and GND	$C_{\phi H1}, C_{\phi H2}$	38	pF	
Capacitance between Horizontal Transfer Clocks	$C_{\phi H12}$	38	pF	
Capacitance between Reset Gate Clock and GND	$C_{\phi RG}$	10	pF	
Capacitance between Substrate Clock and GND	$C_{\phi SUB}$	1120	pF	
Vertical Transfer Clock Serial Resistor	$R_{\phi V1} \sim R_{\phi V4}$	40	$\Omega$	
Vertical Transfer Clock Ground Resistor	$R_{GND}$	15	$\Omega$	
Horizontal Transfer Clock Serial Resistor	$R_{\phi H1}, R_{\phi H2}$	10	$\Omega$	
Reset Gate Clock Serial Resistor	$R_{\phi RG}$	100	$\Omega$	

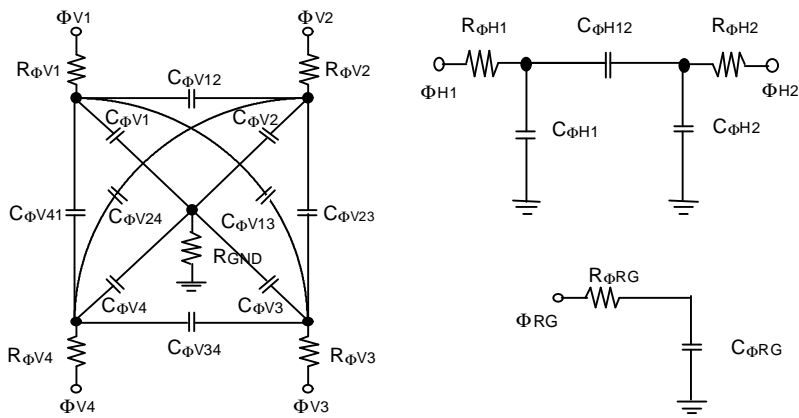

**IMAGE SENSOR CHARACTERISTICS**

(Ta = 25°C)

Item	Symbol	Min.	Typ.	Max.	Unit	Test method	Remark
Sensitivity	S	40	45		mV/lux	1	
Saturation Signal	$Y_{SAT}$		600		mV	2	
Smear	SM			0.015	%	3	
Blooming Margin	BM	1,000			times	4	
Uniformity	U			20	%	5	
Dark Signal	D			2	mV	6	Ta=50°C
Flicker Y	$F_Y$			2	%	7	

**SPECTRAL RESPONSE CHARACTERISTICS**

(Excluding light source characteristics)

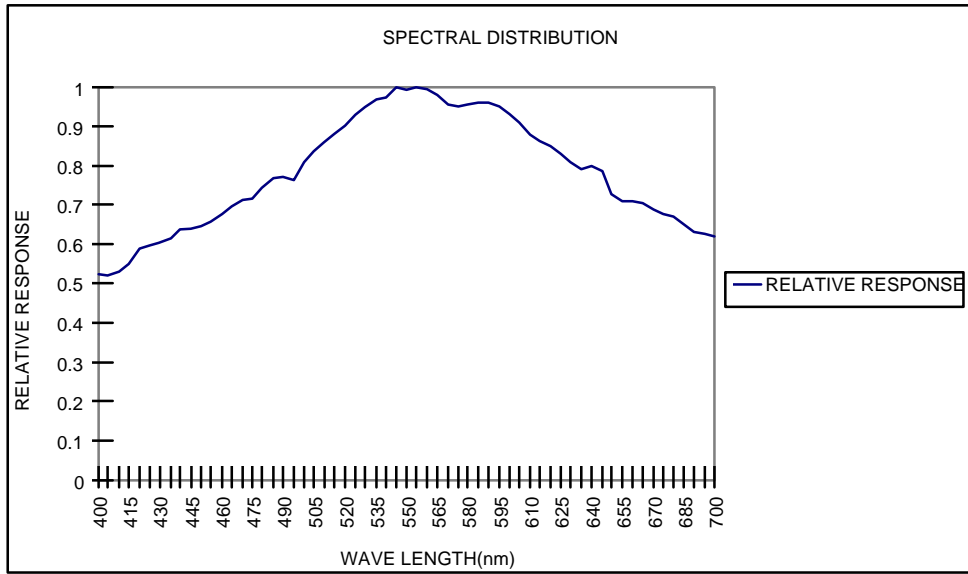

**TEST CONDITION**

- 1) Use a light source with color temperature of 3,200K The light source is adjusted in accordance with the average value of Y signals indicated in each item.
- 2) Through the following tests the substrate voltage and reset gate clock are set to the value of bias condition while the device condition are at the typical value of the bias and clock conditions.
- 3) Through the following tests, defects are excluded and unless otherwise specified the optical black level (hence forth referred as OB) is set for the reference of the output signal which is taken as the Y signal output.

**TEST METHODS**

1. Measure the light intensities (L) when the averaged illuminance output value (Y) is the standard illuminance output value, 150mV ( $Y_A$ ) and when half of 150mV ( $1/2 Y_A$ ).

$$S = \frac{Y_A - \frac{1}{2} Y_A}{L_{Y_A} - L_{\frac{1}{2} Y_A}}$$

2. Adjust the light intensity to 10 times that of Y signal output average value ( $Y_A = 150\text{mV}$ ), then test Y signal minimum value ( $Y=Y_{\text{SAT}}$ ).
3. Adjust the light intensity to 500 times that of Y signal output average value ( $Y_A=150\text{mV}$ ), then remove the read-out clock and drain the signal in photosensors by the electronic shutter operation in all the respective horizontal blanking times with the other clocks unchanged. Measure the maximum illuminance output value ( $Y_{\text{SM}}$ ).

$$SM = \frac{Y_{\text{SM}}}{Y_A} \times \frac{1}{500} \times \frac{1}{10} \times 100(\%)$$

4. Adjust the light intensity to 1000 times that of Y signal output average value ( $Y_A = 150\text{mV}$ ), then confirm that Blooming dose not appear.
5. Measure the maximum and minimum illuminance output value ( $Y_{\text{MAX}}, Y_{\text{MIN}}$ ) when the light Intensity is adjusted to make Y to be  $Y_A$ .

$$U = \frac{Y_{\text{MAX}} - Y_{\text{MIN}}}{Y_A} \times 100(\%)$$

6. Measure Y signal output average value  $Y_D$  [mV] with the horizontal idling time transfer level as reference, when the device ambient temperature is 50°C and all of the light sources are shielded.
7. Adjust the light intensity to make  $Y=Y_A$ . Measure the difference value ( $\Delta Y_F$ ) between the averaged illuminance signal values of the even and odd fields.

$$F_Y = \frac{\Delta Y_F}{Y_A}$$



APPLICATION CIRCUITS

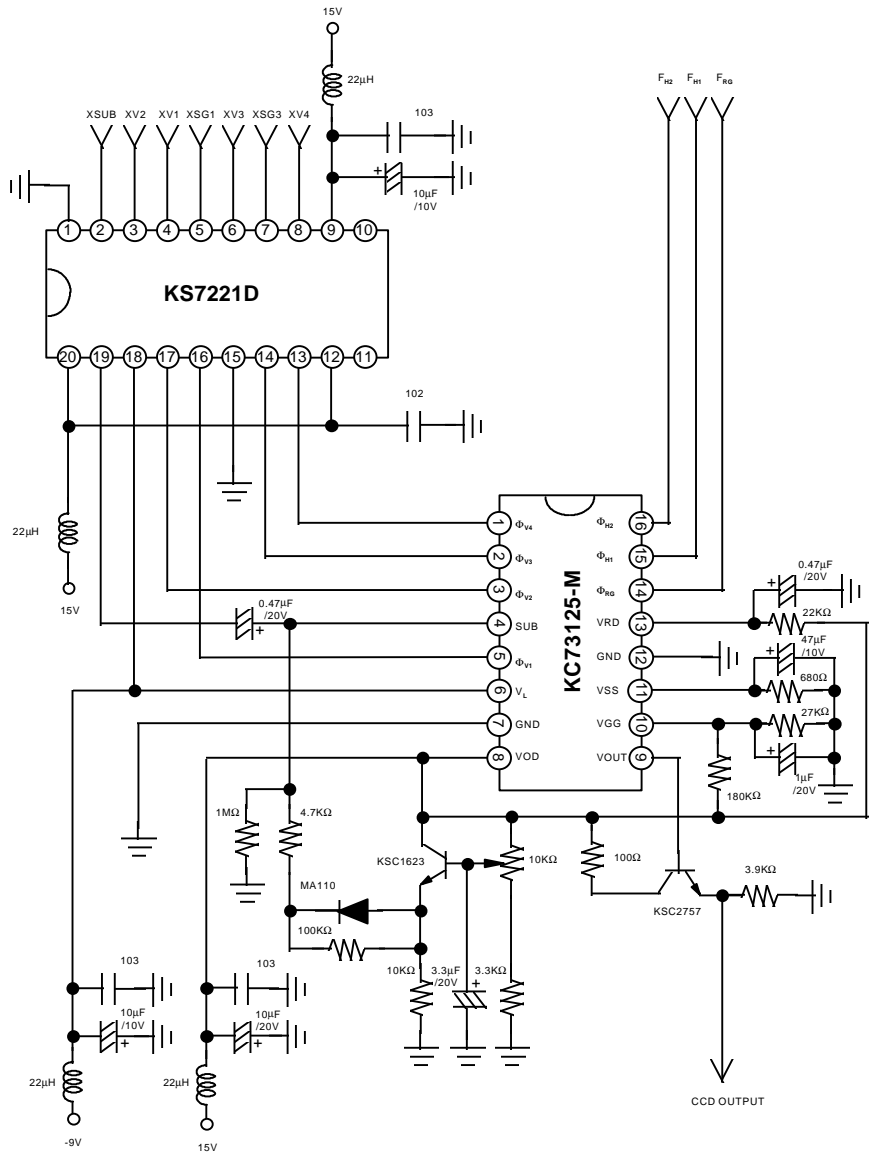

READ-OUT CLOCK TIMING CHART

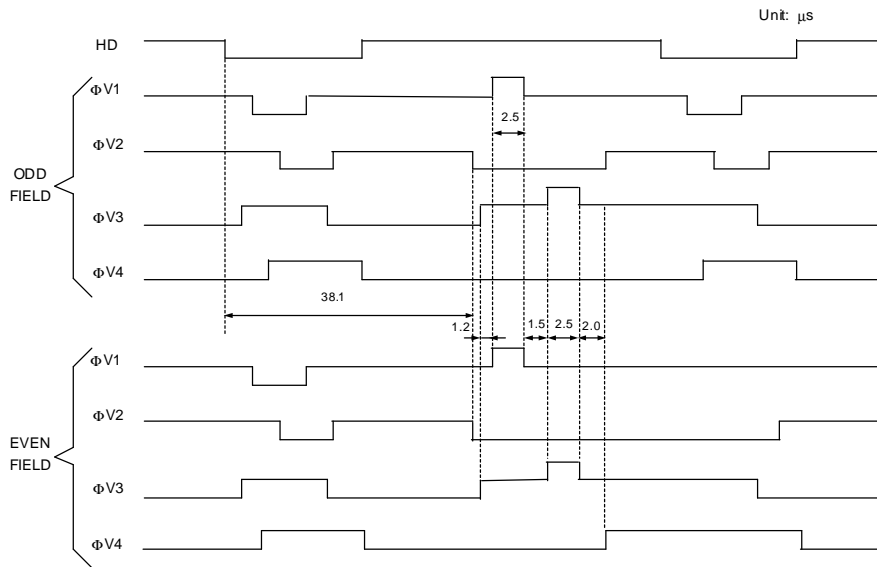

**CLOCK TIMING CHART (VERTICAL SYNC.)**

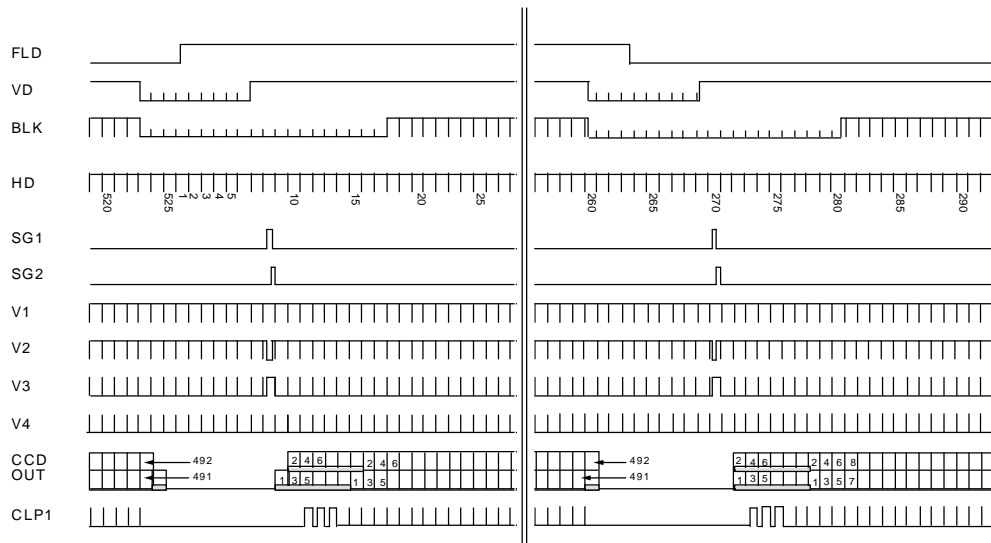

**CLOCK TIMING CHART (HORIZONTAL SYNC.)**

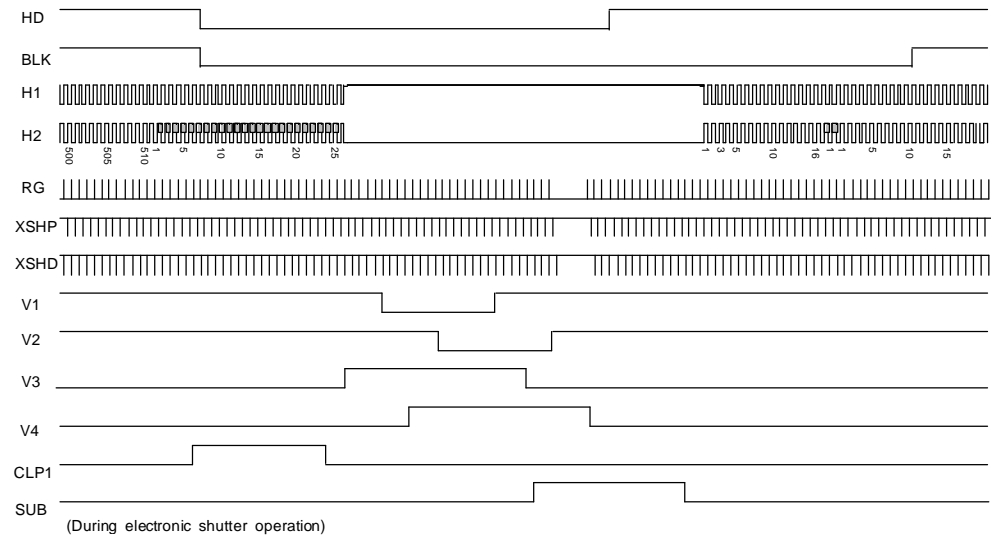

PACKAGE DIMENSIONS

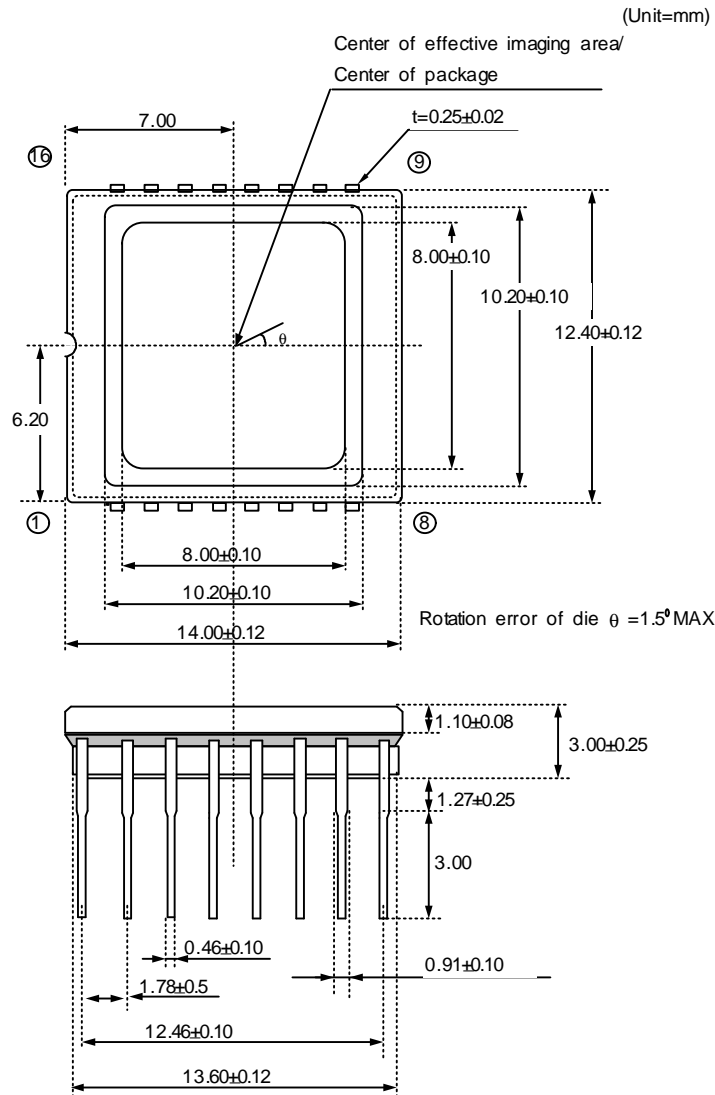

1. Optical center deviation from mechanical center =  $\pm 0.15\text{mm}$  for X and Y direction.
2. Optical surface height from glass lid surface =  $1.1 \pm 0.15\text{mm}$
3. Optical surface height from package backside bottom =  $1.7 \pm 0.10\text{mm}$

**HANDLING INSTRUCTIONS****1. Static charge prevention**

CCD image sensors can be easily damaged by static discharge. Before handling be sure to take the following protective measures.

- 1) Use non chargeable gloves, clothes or material. Also use conductive shoes.
- 2) When handling directly, use an earth band.
- 3) Install a conductive mat on the floor or working table to prevent generation of static electricity.
- 4) Ionized air is recommended for discharging when handling CCD image sensor.
- 5) For the shipment of mounted substrates, use boxes treated for the prevention of static charges.

**2. Soldering**

- 1) Make sure the package temperature does not exceed 80°C
- 2) Solder dipping in a mounting furnace causes damage to the glass and other defects. Use a grounded 30W soldering iron and solder each pin in less than 2 seconds. For repairs and remount, cool sufficiently.
- 3) To dismount an imaging device, do not use a solder suction equipment. When using an electronic desoldering tool, use a thermal controller of the zero cross On/Off type and connect to ground

**3. Dust and Dirt protection**

- 1) Operate in the clean environments (around class 1000 will be appropriate).
- 2) Do not either touch glass plates by hand or have object come in contact with glass surface.  
Should dirt stick to a glass surface blow it off with an air blow (for dirt stuck through static electricity ionized air is recommended).
- 3) Clean with a cotton bud and ethyl alcohol if the glass surface is grease stained. Be careful not to scratch the glass.
- 4) Keep in case to protect from dust and dirt. To prevent dew condensation, preheat or precool when moving to a room with great temperature differences.
- 5) When a protective tape is applied before shipping, just before use remove the tape applied electrostatic protection. Do not reuse the tape.

**4. Do not expose to strong light (sun rays) for long period, color filter are discolored**

**5. Exposure to high temperatures or humidity will affect the characteristics. Accordingly avoid storage or usage in such conditions.**

**6. CCD image sensors are precise optical equipment that should not be subject to mechanical shocks.**