

BCD TO-7 SEGMENT LATCH/DECODER/DRIVER

- **HIGH SPEED**
 $t_{PD} = 15 \text{ ns (Typ)}$ at $V_{CC} = 5V$
- **LOW POWER DISSIPATION**
 $I_{CC} = 4 \mu A \text{ (MAX.)}$ at $T_A = 25^\circ C$
- **HIGH NOISE IMMUNITY**
 $V_{NIH} = V_{NIL} = 28\% V_{CC} \text{ (MIN.)}$
- **OUTPUT DRIVE CAPABILITY**
 10 LSTTL LOADS
- **SYMMETRICAL OUTPUT IMPEDANCE**
 $|I_{OH}| = I_{OL} = 20 \text{ mA (MIN.)}$
- **BALANCED PROPAGATION DELAYS**
 $t_{PLH} = t_{PHL}$
- **WIDE OPERATING VOLTAGE RANGE**
 $V_{CC} \text{ (OPR)} = 2V \text{ to } 6V$
- **PIN AND FUNCTION COMPATIBLE**
 WITH 4511B

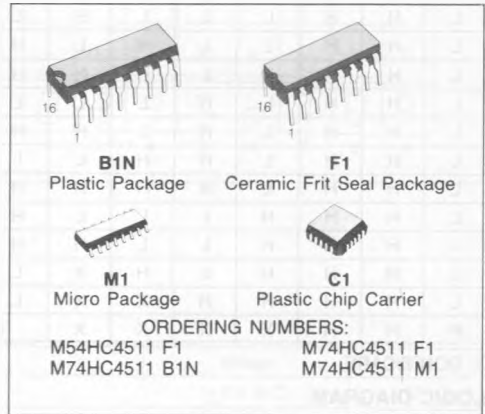

DESCRIPTION

The M54/74HC4511 is a high speed CMOS BCD-TO-7 SEGMENT LATCH/DECODER/DRIVER fabricated with silicon gate C²MOS technology. It enables high speed latch and decode operation with identical pin connection and function to standard CMOS 4511B.

The segment output driver, which is CMOS fabricated in silicon gate C²MOS technology, has large I_{OH} capability which enables common cathode Leds to be directly driven.

When lamp test (\overline{LT}) is taken "L", all segment outputs will go to "H", and when blanking (\overline{BI}) is taken "L" and \overline{LT} is taken "H" all segment outputs will go to "L".

These functions operate regardless of other inputs and are used to test the display.

Input BI is used to pulse-modulate the brightness of the display.

When an error input code (over 10) is applied to the BCD input, all segment outputs will go "L" (turn off).

All inputs are equipped with protection circuits against static discharge and transient excess voltage.

PIN CONNECTION (top view)

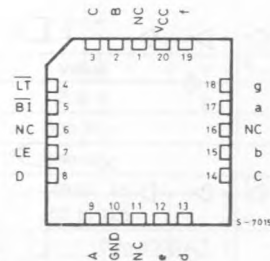
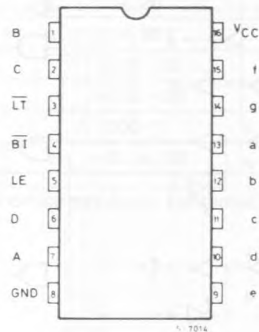

NC =
No Internal
Connection

TRUTH TABLE

INPUTS							OUTPUTS							DISPLAY MODE
LE	\overline{BI}	\overline{LT}	D	C	B	A	a	b	c	d	e	f	g	
X	X	L	X	X	X	X	H	H	H	H	H	H	H	8
X	L	H	X	X	X	X	L	L	L	L	L	L	L	BLANK
L	H	H	L	L	L	L	H	H	H	H	H	H	L	0
L	H	H	L	L	L	H	L	H	H	L	L	L	L	1
L	H	H	L	L	H	L	H	H	L	H	H	L	H	2
L	H	H	L	L	H	H	H	H	L	H	L	L	H	3
L	H	H	L	H	L	L	L	H	H	L	L	H	H	4
L	H	H	L	H	L	H	H	L	H	H	L	H	H	5
L	H	H	L	H	H	L	L	L	H	H	H	H	H	6
L	H	H	L	H	H	H	H	H	H	L	L	L	L	7
L	H	H	H	L	L	L	H	H	H	H	H	H	H	8
L	H	H	H	L	L	H	H	H	L	L	H	H	H	9
L	H	H	H	L	H	X	L	L	L	L	L	L	L	BLANK
L	H	H	H	H	X	X	L	L	L	L	L	L	L	BLANK
H	H	H	X	X	X	X	Hold the stage at the leading edge of LE							

X: DON'T CARE

LOGIC DIAGRAM

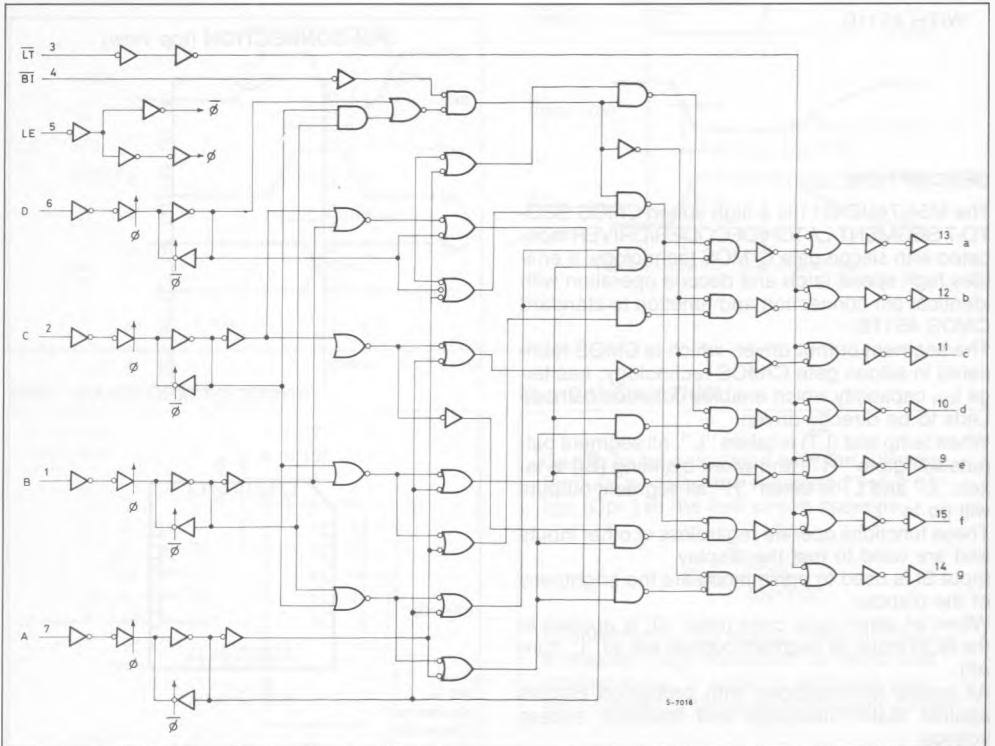

DISPLAY MODE

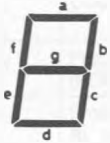

INPUT CODE	A	L	H	L	H	L	H	L	H	L	H
	B	L	L	H	H	L	L	H	H	L	L
	C	L	L	L	L	H	H	H	H	L	L
	D	L	L	L	L	L	L	L	L	H	H
DISPLAY	0	1	2	3	4	5	6	7	8	9	

ABSOLUTE MAXIMUM RATINGS

Symbol	Parameter	Value	Unit
V_{CC}	Supply Voltage	-0.5 to 7	V
V_I	DC Input Voltage	-0.5 to $V_{CC} + 0.5$	V
V_O	DC Output Voltage	-0.5 to $V_{CC} + 0.5$	V
I_{IK}	DC Input Diode Current	± 20	mA
I_{OK}	DC Output Diode Current	± 20	mA
I_O	DC Output Source Sink Current Per Output Pin	+25/-35	mA
I_{CC} or I_{GND}	DC V_{CC} or Ground Current	+150/-50	mA
P_D	Power Dissipation	500 (*)	mW
T_{stg}	Storage Temperature	-65 to 150	$^{\circ}C$

Absolute Maximum Ratings are those values beyond which damage to the device may occur. Functional operation under these condition is not implied.

(*) 500 mW: $\cong 65^{\circ}C$ derate to 300 mW by 10 mW/ $^{\circ}C$: $65^{\circ}C$ to $85^{\circ}C$

RECOMMENDED OPERATING CONDITIONS

Symbol	Parameter	Value	Unit
V_{CC}	Supply Voltage	2 to 6	V
V_I	Input Voltage	0 to V_{CC}	V
V_O	Output Voltage	0 to V_{CC}	V
T_A	Operating Temperature	74HC Series 54HC Series	$^{\circ}C$
		-40 to 85 -55 to 125	
t_r, t_f	Input Rise and Fall Time	V_{CC} $\left\{ \begin{array}{l} 2 \text{ V} \\ 4.5 \text{ V} \\ 6 \text{ V} \end{array} \right.$	ns
		$\left\{ \begin{array}{l} 0 \text{ to } 1000 \\ 0 \text{ to } 500 \\ 0 \text{ to } 400 \end{array} \right.$	

BLOCK DIAGRAM

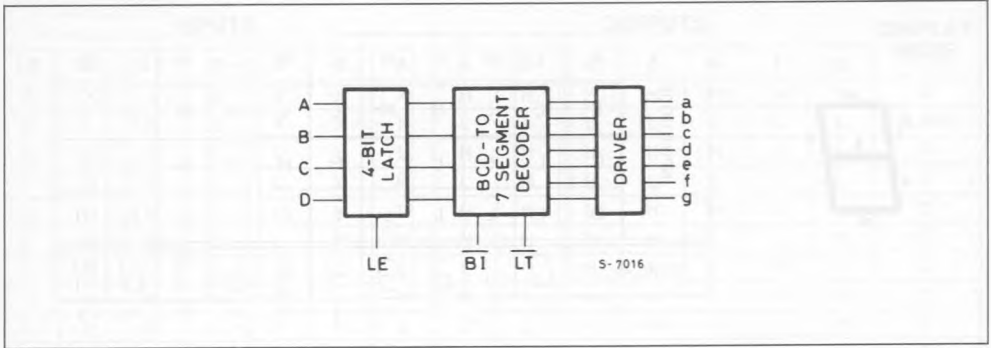

DC ELECTRICAL CHARACTERISTICS

Symbol	Parameter	V _{CC}	Test Condition		T _A = 25°C			-40 to 85°C		-55 to 125°C		Unit		
					54HC and 74HC			74HC		54HC				
					Min.	Typ.	Max.	Min.	Max.	Min.	Max.			
V _{IH}	High Level Input Voltage	2.0 4.5 6.0			1.5 3.15 4.2	— — —	— — —	1.5 3.15 4.2	— — —	1.5 3.15 4.2	— — —	V		
V _{IL}	Low Level Input Voltage	2.0 4.5 6.0			— — —	— — —	0.5 1.35 1.8	— — —	0.5 1.35 1.8	— — —	0.5 1.35 1.8	V		
V _{OH}	High Level Output Voltage	2.0 4.5 6.0 4.5 6.0	V _I	I _O	—	2.0	—	1.9	—	1.9	—	—		
													V _{IH}	-20 μA
			V _{IL}	-6.0 mA -20 mA -5.2 mA	4.18	4.31	—	4.13	—	4.10	—			
					3.20	3.80	—	2.90	—	—	—			
V _{OL}	Low Level Output Voltage	2.0 4.5 6.0 4.5 6.0	V _{IH}	20 μA	—	0.0	0.1	—	0.1	—	0.1	—	—	
														V _{IL}
			—	—	—	—	—	0.0	0.1	—	0.1	—	0.1	—
I _I	Input Leakage Current	6.0	V _I = V _{CC} or GND		—	—	±0.1	—	±1.0	—	±1.0	μA		
I _{CC}	Quiescent Supply Current	6.0	V _I = V _{CC} or GND		—	—	4	—	40	—	80	μA		

AC ELECTRICAL CHARACTERISTICS ($V_{CC} = 5V$, $T_A = 25^\circ C$, $C_L = 15pF$, Input $t_r = t_f = 6ns$)

Symbol	Parameter	54HC and 74HC			Unit
		Min.	Typ.	Max.	
t_{TLH} t_{THL}	Output Transition Time		4	8	ns
t_{PLH} t_{PHL}	Propagation Delay Time (BCD - Segment)		46	71	ns
t_{PHL} t_{PHL}	Propagation Delay Time \overline{BI} - Segment		28	44	ns
t_{PLH} t_{PHL}	Propagation Delay Time \overline{LT} - Segment		16	26	ns
t_{PHL} t_{PHL}	Propagation Delay Time LE - Segment		46	71	ns

SWITCHING CHARACTERISTICS TEST WAVEFORM

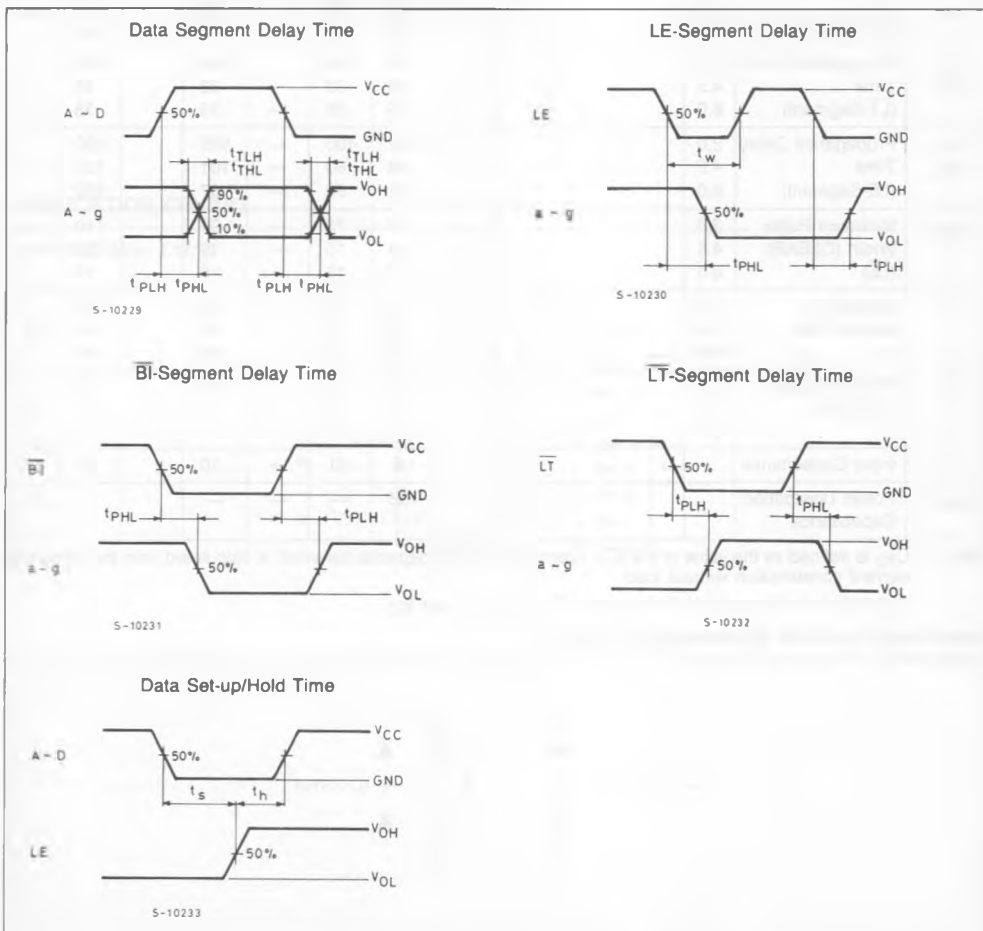

AC ELECTRICAL CHARACTERISTICS (C_L = 50pF, Input t_r = t_f = 6ns)

Symbol	Parameter	V _{CC}	Test Condition	T _A = 25°C 54HC and 74HC			- 40 to 85°C 74HC		- 55 to 125°C 54HC		Unit
				Min.	Typ.	Max.	Min.	Max.	Min.	Max.	
t _{TLH} t _{THL}	Output Transition Time Low to High	2.0		—	25	60	—	75		90	ns
		4.5		—	6	12	—	15		18	
		6.0		—	5	10	—	13		15	
t _{THL}	Output Transition Time High to Low	2.0		—	30	75	—	95	—	110	ns
		4.5		—	8	15	—	19	—	22	
		6.0		—	7	13	—	16	—	19	
t _{PLH} t _{PHL}	Propagation Delay Time (BCD-Segment)	2.0		—	192	400	—	505		600	ns
		4.5		—	48	80	—	101		120	
		6.0		—	41	68	—	87		102	
t _{PLH} t _{PHL}	Propagation Delay Time (BI-Segment)	2.0		—	116	250	—	315		375	ns
		4.5		—	29	50	—	63		75	
		6.0		—	25	43	—	54		64	
t _{PLH} t _{PHL}	Propagation Delay Time (LT-Segment)	2.0		—	72	150	—	190		225	ns
		4.5		—	18	30	—	38		45	
		6.0		—	15	26	—	33		38	
t _{PLH} t _{PHL}	Propagation Delay Time (LE-Segment)	2.0		—	192	400	—	505		600	ns
		4.5		—	48	80	—	101		120	
		6.0		—	41	68	—	87		102	
t _{W(L)}	Minimum Pulse Width (CLEAR) (LE)	2.0		—	30	75	—	95		110	ns
		4.5		—	8	15	—	19		22	
		6.0		—	7	13	—	16		19	
t _s	Minimum Set-up Time	2.0		—	35	75	—	95		110	ns
		4.5		—	9	15	—	19		22	
		6.0		—	8	13	—	16		19	
t _h	Minimum Data Hold Time	2.0		—	—	0	—	0	—	0	ns
		4.5		—	—	0	—	0	—	0	
		6.0		—	—	0	—	0	—	0	
C _{IN}	Input Capacitance			—	5	10	—	10		10	pF
C _{PD} (*)	Power Dissipation Capacitance			—	136	—	—	—			pF

Note (*) C_{PD} is defined as the value of the IC's internal equivalent capacitance which is calculated from the operating current consumption without load.

Average operating current is: I_{CC(opr)} = C_{PD} · V_{CC} · f_{IN} + I_{CC}

INPUT AND OUTPUT EQUIVALENT CIRCUIT

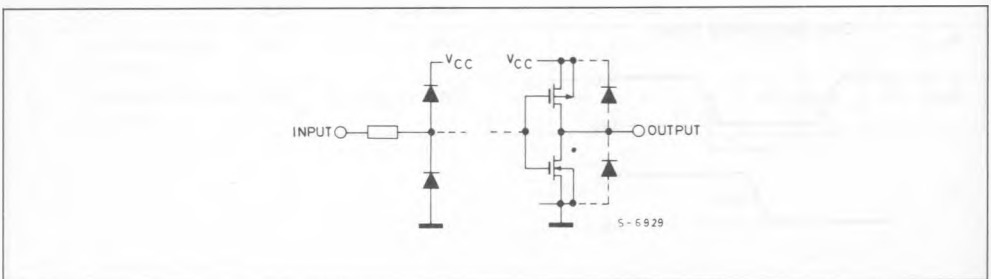

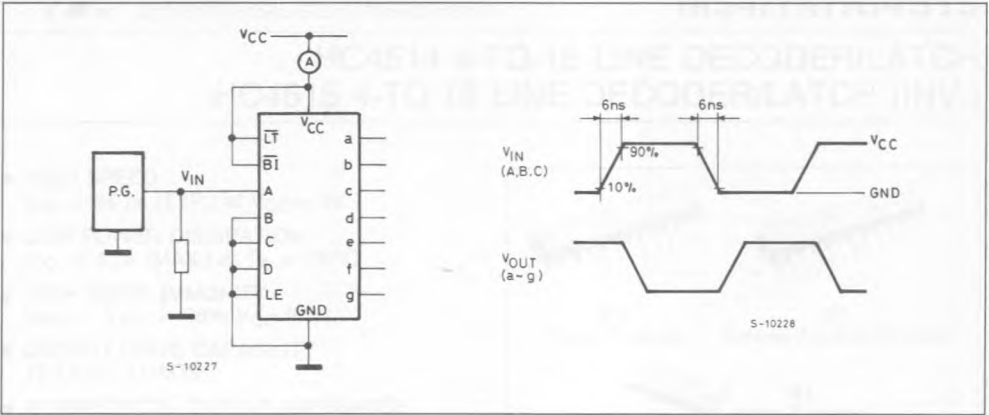
TEST CIRCUIT I_{CC} (Opr.)

APPLICATION CIRCUIT

Static Display Circuit

