

## SERIAL INPUT LCD DRIVER

- DRIVES UP TO 32 LCD SEGMENTS
- DATA TRANSFER: FIXED ENABLE MODE FOR DIP-40, ENABLE AND LATCH-MODE FOR 44PLCC
- INPUTS ARE CMOS, NMOS AND TTL COMPATIBLE
- CASCADABLE
- REQUIRES ONLY 3 CONTROL LINES
- ON CHIP OSCILLATOR
- CMOS TECHNOLOGY FOR WIDE SUPPLY VOLTAGE RANGE
- - 40 TO 85°C TEMPERATURE RANGE

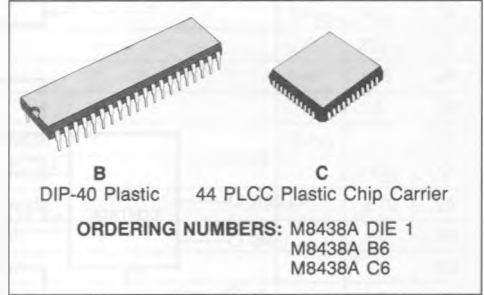

### DESCRIPTION

The M8438A is a CMOS integrated circuit that drives an LCD display, usually under microprocessor control. The part acts as a smart peripheral that drives up to 32 LCD segments. It needs only three control lines due to its serial input construction. It latches the data to be displayed and relieves the microprocessor from the task of generating the required waveforms.

The M8438A can drive any standard or custom parallel drive LCD whether it be field effect or dynamic scattering. Several drivers can be cascaded, if more than 32 segments are to be driven. The AC frequency of the LCD waveforms can be supplied by the user or can be generated by attaching a capacitor to the OSC input which determines the frequency of an internal oscillator.

The M8438A is available in DIE form and assembled in 40 pin dual-in line plastic or 44 PLCC packages.

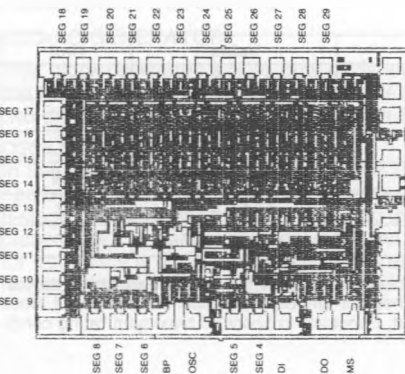

### PIN CONNECTIONS

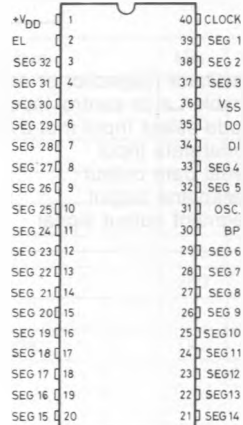

S-8309

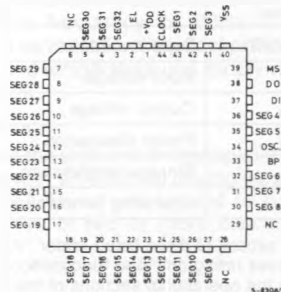

S-8304

**BLOCK DIAGRAM**

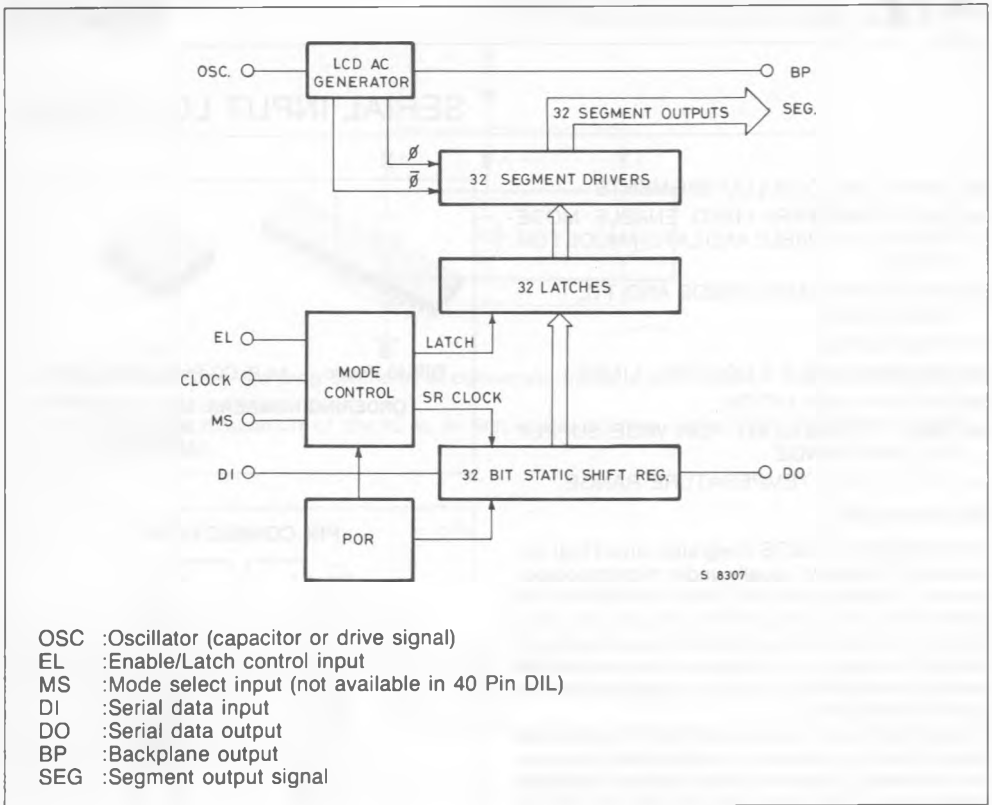

**ABSOLUTE MAXIMUM RATINGS**

| Symbol           | Parameter             | Value                  | Unit |
|------------------|-----------------------|------------------------|------|
| (VDD-VSS)        | Supply voltage        | - 0.3 to +12           | V    |
| V <sub>I</sub>   | Input voltage         | VSS - 0.3 to VDD + 0.3 | V    |
| V <sub>O</sub>   | Output voltage        | VSS - 0.3 to VDD + 0.3 | V    |
| P <sub>D</sub>   | Power dissipation     | 250                    | mW   |
| T <sub>stg</sub> | Storage temperature   | - 55 to +125           | °C   |
| T <sub>A</sub>   | Operating temperature | - 40 to +85            | °C   |

Stresses in excess of those listed under "Absolute Maximum Ratings" may cause permanent damage to the device. This is a stress rating only and functional operation of the device at these or any other conditions in excess of those indicated in the operational sections of this specification is not implied. Exposure to absolute maximum rating conditions for extended periods may affect device reliability.

**ELECTRICAL CHARACTERISTICS** ( $T_{amb} = 25^{\circ}\text{C}$  and  $V_{DD} = 5\text{V}$  unless otherwise noted)**STATIC ELECTRICAL CHARACTERISTICS**

| Symbol    | Parameter                  | Test Condition                                      | Min.       | Max.       | Unit             |
|-----------|----------------------------|---|------------|------------|------------------|
| $V_{DD}$  | Supply Voltage             |   | 3          | 10         | V                |
| $I_{DD}$  | Supply Current             | Oscillator $f < 15\text{kHz}$                       |            | 60         | $\mu\text{A}$    |
| $I_Q$     | Quiescent Current          | $V_{DD} = 10\text{V}$                               |            | 10         | $\mu\text{A}$    |
| $V_{IH}$  | Input High Level           |   | $.5V_{DD}$ | $V_{DD}$   | V                |
| $V_{IL}$  | Input Low Level            | CLOCK<br>DI<br>EL                                   | 0          | $.2V_{DD}$ | V                |
| $I_{IN}$  | Input Current              |   |            | $\pm 5$    | $\mu\text{A}$    |
| $C_I$     | Input Capacitance          |   |            | 5          | pF               |
| $V_{IH}$  | Input High Level           | OSC<br>Driven mode                                  | $.9V_{DD}$ |            | V                |
| $V_{IL}$  | Input Low Level            | Driven mode   |            | $.1V_{DD}$ | V                |
| $I_{IN}$  | Input Current              | Driven mode   |            | $\pm 10$   | $\mu\text{A}$    |
| $R_{ON}$  | Segment Output Impedance   | $I_{IL} = 10\mu\text{A}$                            |            | 40         | $\text{k}\Omega$ |
| $R_{ON}$  | Backplane Output Impedance | $I_L = 100\mu\text{A}$                              |            | 3          | $\text{k}\Omega$ |
| $V_{OFF}$ | Output Offset Voltage      | $C_L = 250\text{pF}$ between each SEG output and BP |            | $\pm 50$   | mV               |
| $R_{ON}$  | Data Output Impedance      | $I_L = 100\mu\text{A}$                              |            | 3          | $\text{k}\Omega$ |

**DYNAMIC ELECTRICAL CHARACTERISTICS**

| Symbol   | Parameter            | Test Condition                 | Min. | Max. | Unit |
|----------|----------------------|--------------------------------|------|------|------|
| $t_{TR}$ | Transition Time OSC  | Driven mode                    |      | 500  | ns   |
| $t_{SD}$ | Data Set-up Time     | Fig. 1 and 2                   | 150  |      | ns   |
| $t_{HD}$ | Data Hold Time       | Fig. 1 and 2                   | 50   |      | ns   |
| $t_{SE}$ | EL Set-up Time       | Fig. 1                         | 100  |      | ns   |
| $t_{HE}$ | EL Hold Time         | Fig. 1                         | 100  |      | ns   |
| $t_{WE}$ | EL Pulse Width       | Fig. 2                         | 175  |      | ns   |
| $t_{CE}$ | Clock to EL Time     | Fig. 2                         | 250  |      | ns   |
| $t_{pd}$ | DO Propagation Delay | Fig. 1, 2; $C_L = 55\text{pF}$ |      | 500  | ns   |
| $f$      | Clock Rate           | $V_{DD} = 10$ 50% duty cycle;  | DC   | 1.5  | MHz  |

**FUNCTIONAL DESCRIPTION****LCD-AC-GENERATOR**

This block generates a 50% duty cycle signal for the backplane output. The circuit can be used in two different modes: oscillator or driven.

**OSCILLATOR MODE:**

In this mode the backplane frequency is determined by the internal RC oscillator together with an 8-stage frequency divider. For generating the backplane output signal of 50% duty cycle the oscillator frequency is divided by 256. The RC oscillator requires an external capacitor to be connected bet-

ween input OSC and VSS. A value of 18pF gives a backplane frequency of  $80\text{Hz} \pm 30\%$  at  $V_{DD} = 5\text{V}$ . The variation of the backplane frequency over the entire temperature and supply voltage range is  $\pm 50\%$ .

**DRIVEN MODE:**

In this mode the signal at the backplane output BP is in phase with an external driving signal applied to input OSC. This mode is used to synchronize the LCD drive of two or more cascaded driver circuits.

## FUNCTIONAL DESCRIPTION (continued)

### DETECTION LOGIC

The circuit is able to distinguish between the conditions for oscillator or driven mode. If the circuit is to be in the oscillator mode, the OSC pin has a capacitor connected to it. The oscillator will start as soon as the supply voltage exceeds a certain minimum value. The signal at pin OSC swings within a range from  $0.3V_{DD}$  to  $0.7V_{DD}$ . If the circuit is to be in the driven mode, the OSC pin has to be forced to logic levels by an external source. The transition time between the logic levels must be short, so that the circuit does not react on the voltage level in between. In the driven mode the 8-stage frequency divider is by-passed.

### SEGMENT OUTPUTS

A logic 0 at the data input DI causes a segment output signal to be in phase with the backplane signal and turns the segment off. A logic 1 causes a segment output to be in opposite phase to the backplane signal and turns the segment on.

### MICROPROCESSOR INTERFACE

The circuit can operate in two different data transfer modes: Enable mode and latch mode. One of either mode can be chosen with the mode select input MS. An internal pull up device is provided between this input and VDD. Enable mode is selected if MS is left open or connected to VDD. Latch mode is selected if MS is connected to VSS. **The input MS is not available, if the device is assembled in the 40 pin package, and is internally fixed to operate in ENABLE MODE.**

### ENABLE MODE

Fig. 3 shows a timing diagram of the enable mode. Data is serially shifted in and out of the shift register on the negative transition of the clock. Serial entry into the shift register is permitted when the enable/latch control EL is high. When EL is low it causes the shift register clock to be inhibited and the content of the shift register to be loaded into the latches that control the segment drivers.

### LATCH MODE

Fig. 4 shows a timing diagram of the latch mode. Data is serially shifted in and out of the shift register on the negative transition of the clock. Serial entry into the shift register is permitted independently of the enable/latch control EL. When EL is high it causes a parallel load of the content in the shift register into the latches. It is accepta-

ble to tie the EL line high. Then the latches are transparent and only two lines, clock and data input, would then be needed for data transfer.

### POWER-ON LOGIC

A power on reset pulse is generated internally when the supply voltage is being turned on. The generation of the reset pulse is level dependent and will occur even on a slowly rising supply voltage. The power on reset pulse resets all shift register stages and the latches that control the segment drivers. Therefore all segment outputs are initially in phase with the backplane output. This causes the display to be blanked and no arbitrary data to show up. This condition is maintained until data is shifted into the register and loaded into the latches.

### CONDITIONS FOR POWER-ON RESET FUNCTION

The POR circuit triggers on the rising slope of the positive supply voltage  $V_{DD}$ . A reset pulse will be generated, if conditions a) through d) are given:

- Level  
Rising slope from  $V_1$  to  $V_2$   
 $V_1 \text{ max} = 0.5V$   
 $V_2 \text{ min} = 3.0V$
- Rise time  
 $t_r \text{ min} = 10 \mu\text{s}$   
 $t_r \text{ max} = 1 \text{ s}$
- Rise function  
The function of  $V_{DD}$  between  $t_1$  and  $t_2$  may be nonlinear, but should not show a maximum and should not exceed  $0.25 V/\mu\text{s}$ .
- Recovery time  
The minimum time between turn-off and turn-on of  $V_{DD}$  is 1s.

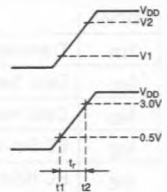

### CASCADE CONFIGURATION

Several LCD drivers can be cascaded if a liquid crystal display with more than 32 segments is to be connected.

The phase correlation between all segment outputs is achieved by using the second (and any other) device in the driven mode.

Two different cascade configurations can be chosen depending whether the LCD frequency is to be determined by the internal RC oscillator or by an external signal.

Figure 3 shows the connection scheme for a self oscillating configuration, figure 4 shows the connection of an externally controlled one.

Fig. 1 - Timing diagram of enable mode: set-up and hold time

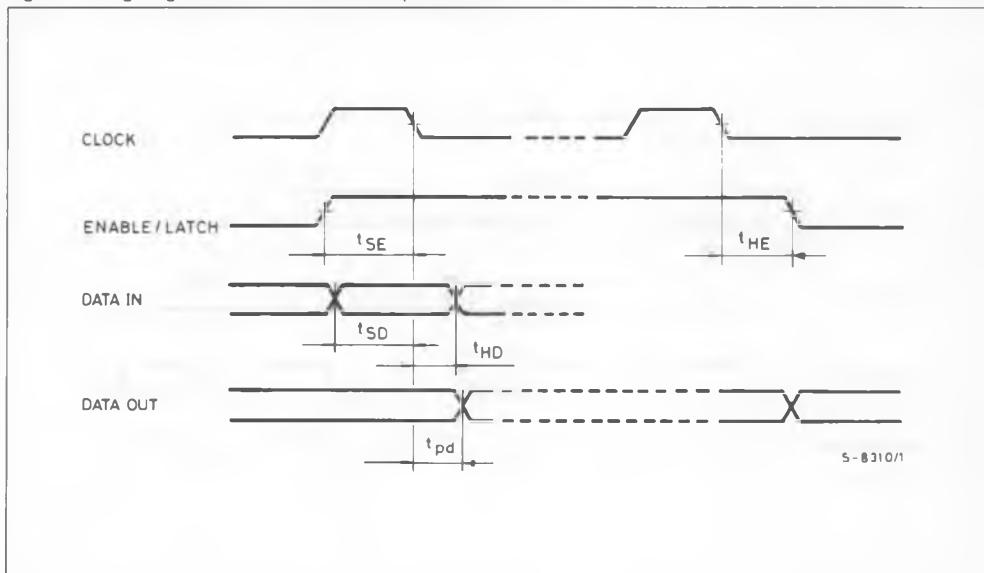

Fig. 2 - Timing diagram of latch mode: set-up and hold time

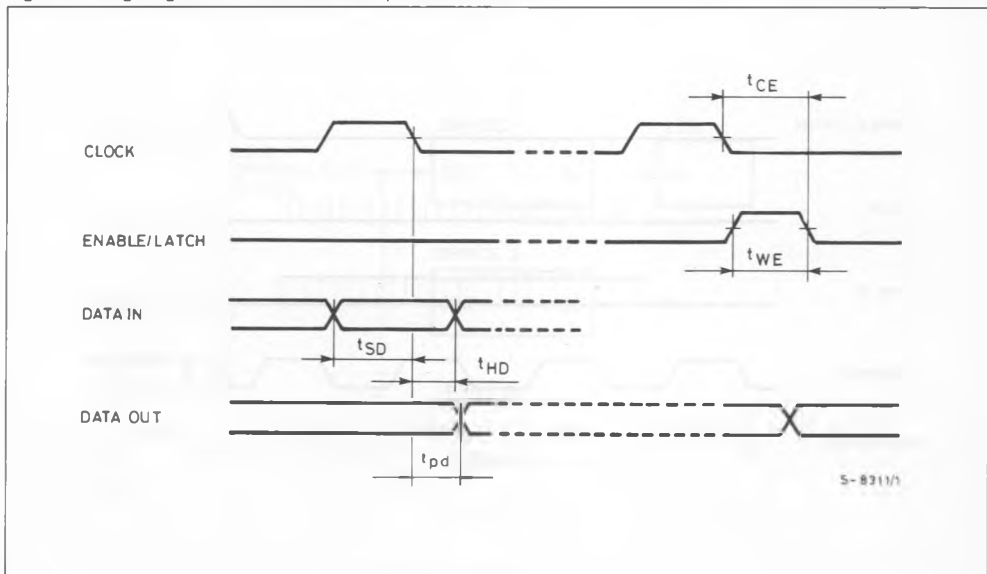

Fig. 3 - Timing diagram of enable mode: Serial load into SR and parallel transfer to LCD

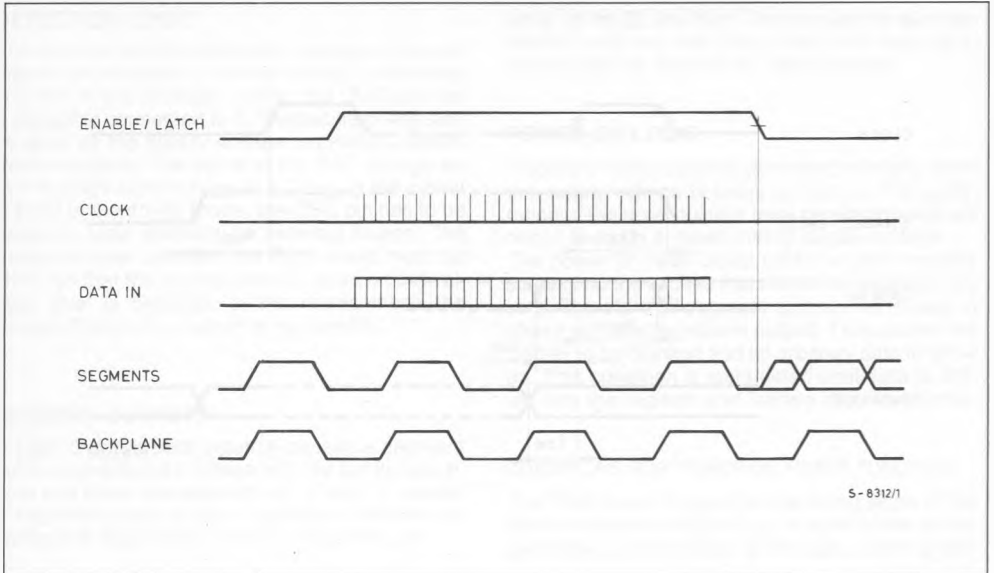

Fig. 4 - Timing diagram of latch mode: Serial load into SR and parallel transfer to LCD

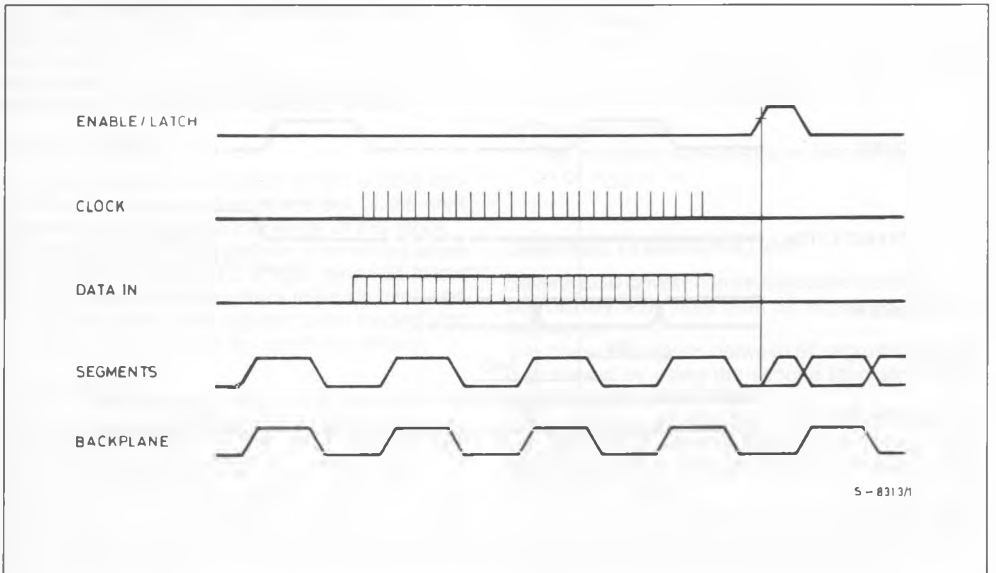

Fig. 5 - Cascade configuration, self oscillating

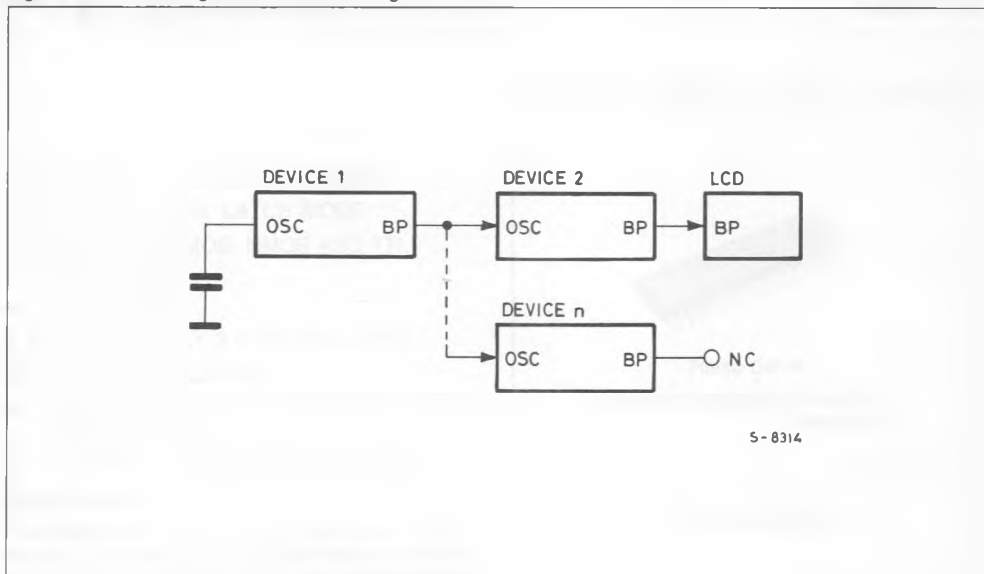

Fig. 6 - Cascade configuration, drive by external signal

