

# MAXIM

## 3 1/2 Digit A/D Converters with Bandgap Reference

MAX130/MAX131

### General Description

The MAX130 and MAX131 are 3 1/2 digit A/D converters with onboard LCD display drivers. The MAX130 and MAX131 use a bandgap reference to generate an analog Common voltage which has the excellent long term stability of a bandgap reference and a guaranteed maximum temperature coefficient of 100ppm/°C. For more demanding applications the "A suffix" parts, the MAX130A and MAX131A, have a 50ppm/°C maximum temperature coefficient.

The MAX130 uses the same circuit and component values as the ICL7106, but draws a maximum supply current of only 250µA maximum (100µA typical) from a 9V battery, much lower than the 1800µA maximum supply current of the ICL7106. The MAX131 uses the same circuit and component values as the ICL7136, with a maximum supply current of 100µA (65µA typical).

These devices are available with both 0°C to 70°C and -40°C to +85°C operating temperature ranges. The operating voltage range is from 4.5V to 14V.

### Applications

- Digital Multimeters
- Digital Panel Meters
- Temperature Meters
- pH Meters

### Features

- ◆ Pin Compatible Upgrade for ICL7106 and ICL7136
- ◆ High Stability Bandgap Reference
- ◆ 50ppm/°C Maximum Temperature Coefficient (MAX130A/MAX131A)
- ◆ 100µA Maximum Supply Current (MAX131)
- ◆ 4.5V to 14V Supply Voltage Range
- ◆ Onboard 3 1/2 Digit LCD Display Driver
- ◆ Available in Industrial Temperature Grades

### Ordering Information

PART	TEMP. RANGE	PACKAGE
MAX130CPL	0°C to +70°C	40 Lead Plastic DIP
MAX130CQH	0°C to +70°C	44 Lead Plastic Chip Carrier
MAX130C/D	0°C to +70°C	Dice
MAX130EPL	-40°C to +85°C	40 Lead Plastic DIP
MAX130EQH	-40°C to +85°C	44 Lead Plastic Chip Carrier
MAX130ACPL	0°C to +70°C	40 Lead Plastic DIP
MAX130ACQH	0°C to +70°C	44 Lead Plastic Chip Carrier
MAX130AEPL	-40°C to +85°C	40 Lead Plastic DIP
MAX130AEQH	-40°C to +85°C	44 Lead Plastic Chip Carrier
MAX131CPL	0°C to +70°C	40 Lead Plastic DIP
MAX131CQH	0°C to +70°C	44 Lead Plastic Chip Carrier

(Ordering information continued on last page.)

### Typical Operating Circuit

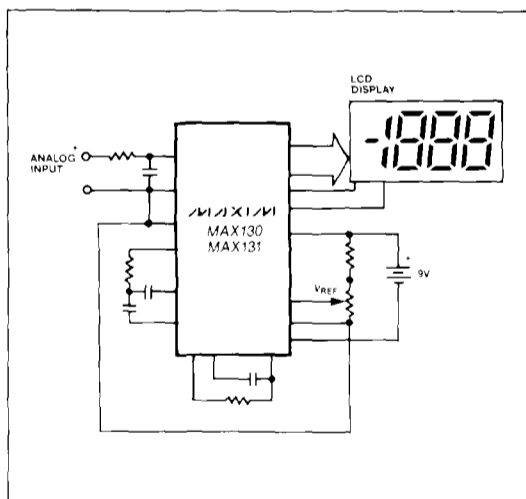

### Pin Configuration

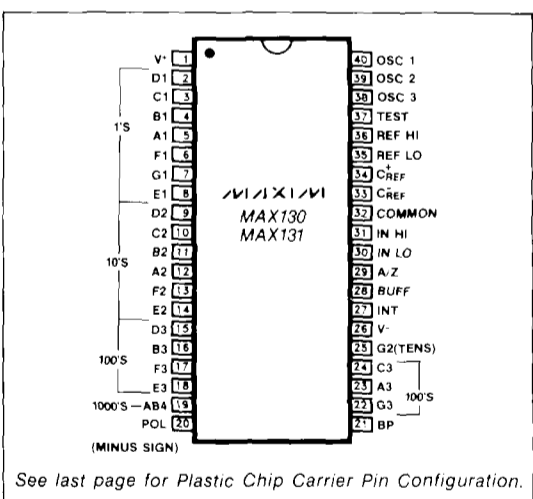

## 3 1/2 Digit A/D Converters with Bandgap Reference

### ABSOLUTE MAXIMUM RATINGS

Supply Voltage (V <sup>+</sup> to V <sup>-</sup> )	15V
Analog Input Voltage (either input) (Note 1)	V <sup>+</sup> to V <sup>-</sup>
Reference Input Voltage (either input)	V <sup>+</sup> to V <sup>-</sup>
Clock Input	TEST to V <sup>+</sup>
Power Dissipation (Note 2)	
CERDIP Package	1000mW
Plastic Package	800mW

Operating Temperature Range	
MAX130C/AC, MAX131C/AC	0°C to +70°C
MAX130E/AE, MAX131E/AE	-40°C to +85°C
Storage Temperature Range	-65°C to +160°C
Lead Temperature (Soldering, 10 sec.)	+300°C

- Note 1:** Input voltages may exceed the supply voltages, provided the input current is limited to  $\pm 100\mu\text{A}$ .
- Note 2:** Dissipation rating assumes device is mounted with all leads soldered to printed circuit board.

Stresses above those listed under "Absolute Maximum Ratings" may cause permanent damage to the device. These are stress ratings only, and functional operation of the device at these or any other conditions above those indicated in the operational sections of the specification is not implied. Exposure to absolute Maximum ratings conditions for extended periods may affect the device reliability.

### ELECTRICAL CHARACTERISTICS (MAX130, MAX130A)

(V<sup>+</sup> = 9V, T<sub>A</sub> = 25°C, f<sub>CLOCK</sub> = 48kHz; test circuit - Figure 1; unless noted)

PARAMETERS	CONDITIONS	MIN	TYP	MAX	UNITS
Zero Input Reading	V <sub>IN</sub> = 0.0V, Full Scale = 200.0mV T <sub>A</sub> = 25°C (Note 3) T <sub>MIN</sub> to T <sub>MAX</sub> (Note 4)	-000.0 -000.0	±000.0 ±000.0	+000.0 +000.0	Digital Reading
Ratiometric Reading	V <sub>IN</sub> = V <sub>REF</sub> , V <sub>REF</sub> = 100mV T <sub>A</sub> = 25°C (Note 3) T <sub>MIN</sub> to T <sub>MAX</sub> (Note 4)	999 998	999/1000 999/1000	1000 1001	Digital Reading
Rollover Error (Difference in reading for equal positive and negative reading near Full Scale)	-V <sub>IN</sub> = +V <sub>IN</sub> ≅ 200.0mV T <sub>A</sub> = 25°C (Note 3) T <sub>MIN</sub> to T <sub>MAX</sub> (Note 4)	-1	±2 ±2	+1	Counts
Linearity (Max. deviation from best straight line fit)	Full Scale = 200.0mV or full scale = 2.000V (Note 5)	-1	±2	+1	Counts
Common Mode Rejection Ratio	V <sub>CM</sub> = ±1V, V <sub>IN</sub> = 0V Full Scale = 200.0mV		50		μV/V
Noise (Pk-Pk value not exceeded 95% of time)	V <sub>IN</sub> = 0V Full Scale = 200.0mV		15		μV
Input Leakage Current	V <sub>IN</sub> = 0 T <sub>A</sub> = 25°C (Note 3) T <sub>MIN</sub> to T <sub>MAX</sub>		1 20	10 200	pA
Zero Reading Drift	V <sub>IN</sub> = 0 T <sub>MIN</sub> to T <sub>MAX</sub> (Note 3)		0.2		μV/°C
Scale Factor Temperature Coefficient	V <sub>IN</sub> = 199.0mV T <sub>MIN</sub> to T <sub>MAX</sub> (Ext. Ref. 0ppm/°C) (Note 3)		1		ppm/°C
V <sup>+</sup> Supply Current	V <sub>IN</sub> = 0 T <sub>A</sub> = 25°C T <sub>MIN</sub> to T <sub>MAX</sub>		100	250 400	μA
Analog Common Voltage (with respect to Pos. Supply)	25kΩ between Common & Pos. Supply	2.95	3.05	3.15	V
Temp. Coeff. of Analog Common (with respect to Pos. Supply)	25kΩ between Common & Pos. Supply (Note 7)		±20 ±20	±100 ±50	ppm/°C
Pk-Pk Segment Drive Voltage, Pk-Pk Backplane Drive Voltage	V <sup>+</sup> to V <sup>-</sup> = 9V	4	5	6	V
Test Pin Voltage	With Respect to V <sup>+</sup>	4	5	6	V

## 3½ Digit A/D Converters with Bandgap Reference

**MAX130/MAX131**

### ELECTRICAL CHARACTERISTICS (MAX131, MAX131A)

(V<sup>+</sup> = 9V, T<sub>A</sub> = 25°C, f<sub>CLOCK</sub> = 48kHz; test circuit - Figure 2; unless noted)

PARAMETERS	CONDITIONS	MIN	TYP	MAX	UNITS
Zero Input Reading	V <sub>IN</sub> = 0.0V, Full Scale = 200.0mV T <sub>A</sub> = 25°C (Note 3) T <sub>MIN</sub> to T <sub>MAX</sub> (Note 4)	-000.0 -000.0	±000.0 ±000.0	+000.0 +000.0	Digital Reading
Ratiometric Reading	V <sub>IN</sub> = V <sub>REF</sub> , V <sub>REF</sub> = 100mV T <sub>A</sub> = 25°C (Note 3) T <sub>MIN</sub> to T <sub>MAX</sub> (Note 4)	999 998	999/1000 999/1000	1000 1001	Digital Reading
Rollover Error (Difference in reading for equal positive and negative reading near Full Scale)	-V <sub>IN</sub> = +V <sub>IN</sub> ≅ 200.0mV T <sub>A</sub> = 25°C (Note 3) T <sub>MIN</sub> to T <sub>MAX</sub> (Note 4)	-1	±2 ±2	+1	Counts
Linearity (Max. deviation from best straight line fit)	Full Scale = 200.0mV or full scale = 2.000V (Note 5)	-1	±2	+1	Counts
Common Mode Rejection Ratio	V <sub>CM</sub> = ±1V, V <sub>IN</sub> = 0V Full Scale = 200.0mV		1		μV/V
Noise (Pk-Pk value not exceeded 95% of time)	V <sub>IN</sub> = 0V Full Scale = 200.0mV		10		μV
Input Leakage Current	V <sub>IN</sub> = 0 T <sub>A</sub> = 25°C (Note 3) T <sub>MIN</sub> to T <sub>MAX</sub>		1	10 200	pA
Zero Reading Drift	V <sub>IN</sub> = 0 T <sub>MIN</sub> to T <sub>MAX</sub> (Note 3)		0.2		μV/°C
Scale Factor Temperature Coefficient	V <sub>IN</sub> = 199.0mV T <sub>MIN</sub> to T <sub>MAX</sub> (Ext. Ref. 0ppm/°C) (Note 3)		1		ppm/°C
V <sup>+</sup> Supply Current	V <sub>IN</sub> = 0 T <sub>A</sub> = 25°C T <sub>MIN</sub> to T <sub>MAX</sub>		60	100 120	μA
Analog Common Voltage (with respect to Pos. Supply)	250kΩ between Common & Pos. Supply	2.95	3.05	3.15	V
Temp. Coeff. of Analog Common (with respect to Pos. Supply)	250kΩ between Common & Pos. Supply (Note 7)		±20 ±20	±50 ±100	ppm/°C
Pk-Pk Segment Drive Voltage, Pk-Pk Backplane Drive Voltage	V <sup>+</sup> to V <sup>-</sup> = 9V	4	5	6	V
Test Pin Voltage	With Respect to V <sup>+</sup>	4	5	6	V

**Note 3:** Test condition is V<sub>IN</sub> applied between pin IN-HI and IN-LO through a 1MΩ series resistor as shown in Figures 1 and 2.

**Note 4:** 1MΩ resistor is removed in Figures 1 and 2.

**Note 5:** Guaranteed by design.

**Note 6:** All pins are designed to withstand electrostatic discharge (ESD) levels in excess of 2000V. (Test circuit per Mil Std 883, Method 3015.1.)

**Note 7:** MAX130 and MAX131 temperature coefficient is guaranteed by sample testing. MAX130A and MAX131A temperature coefficient is 100% tested.

## 3 1/2 Digit A/D Converters with Bandgap Reference

### Basic Applications

Figures 1 and 2 show the basic MAX130 and MAX131 applications circuits. Note that the circuits for the MAX130 and the MAX131 use different values for the integration and oscillator components. The MAX130 can operate using the MAX131 component values, but the MAX131 will not operate using the MAX130 component values. The lower supply current device, the MAX131, must always use the higher value integrator resistor as shown in component value table in Figure 2. With a typical operating current of only 65µA, the MAX131 will operate for about 8500 hours when powered by a typical 550mAh alkaline 9V battery. The MAX130 will operate for 2200 hours with a 550mAh battery.

### Compatibility with ICL7106 and ICL7136

The MAX130 and MAX131 can directly replace the ICL7106 and ICL7136 with no circuit layout or component value changes in circuits which are designed to use the Common voltage as the reference. In ICL7106/7136 circuits which are designed to use an external bandgap reference, the bandgap reference diode can be removed with no circuit changes required. Normally the value of the resistor between V<sup>+</sup> and the bandgap reference diode is the only component value that must be changed to allow the removal of an external bandgap reference diode.

### System Reference Point

The analog block diagram (Figures 3) of the MAX130 is similar to that of the MAX131 (Figure 4). The only difference is the voltage at the non-inverting terminal of the integrator during the de-integrate, autozero and zero integrator phases. The MAX130 drives the non-inverting terminal of the integrator with the Common pin during these phases, as does the ICL7106. The MAX131 uses the In Lo pin as the reference point for the integrator during all phases, as does Maxim's ICL7136.

The circuit configuration of the MAX131 results in an excellent 120dB rejection of DC common mode voltages applied to In Hi and In Lo. The MAX131 configuration, though, does not have good rejection of AC noise on the In Lo pin during de-integration. If an AC-DC converter is used with a MAX131 it should either be a half-wave circuit (leaving In Lo connected to Common) or should have adequate filtering to avoid inducing additional noise.

The circuit configuration of the MAX130 is unaffected by AC noise on the In Lo pin during de-integrate, but the rejection of DC common mode signals on In Hi and In Lo is only about 86dB, the same as the ICL7106. The input voltage at the MAX130 In Lo pin should be restricted to no more than 1V above the Common pin.

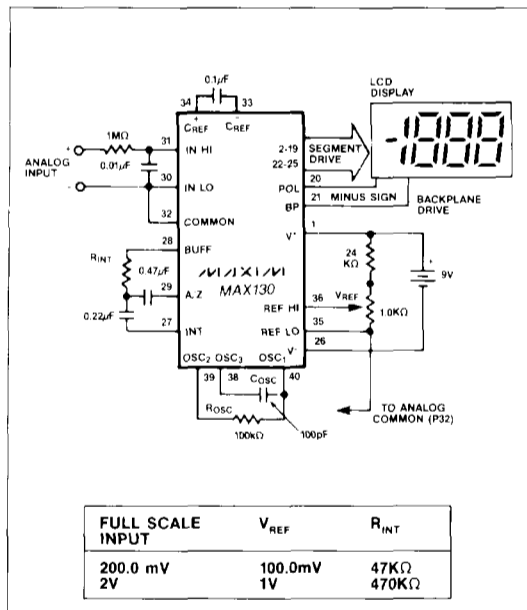

Figure 1. Maxim MAX130 Typical Operating Circuit, 3 Conversions per Second

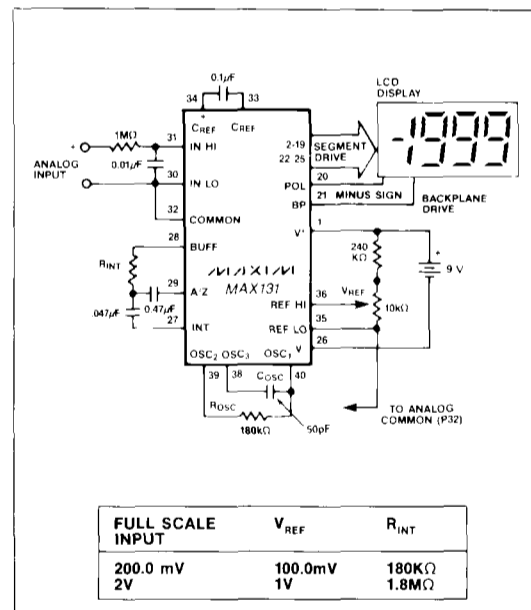

Figure 2. Maxim MAX131 Typical Operating Circuit, 3 Conversions per Second

### 3½ Digit A/D Converters with Bandgap Reference

MAX130/MAX131

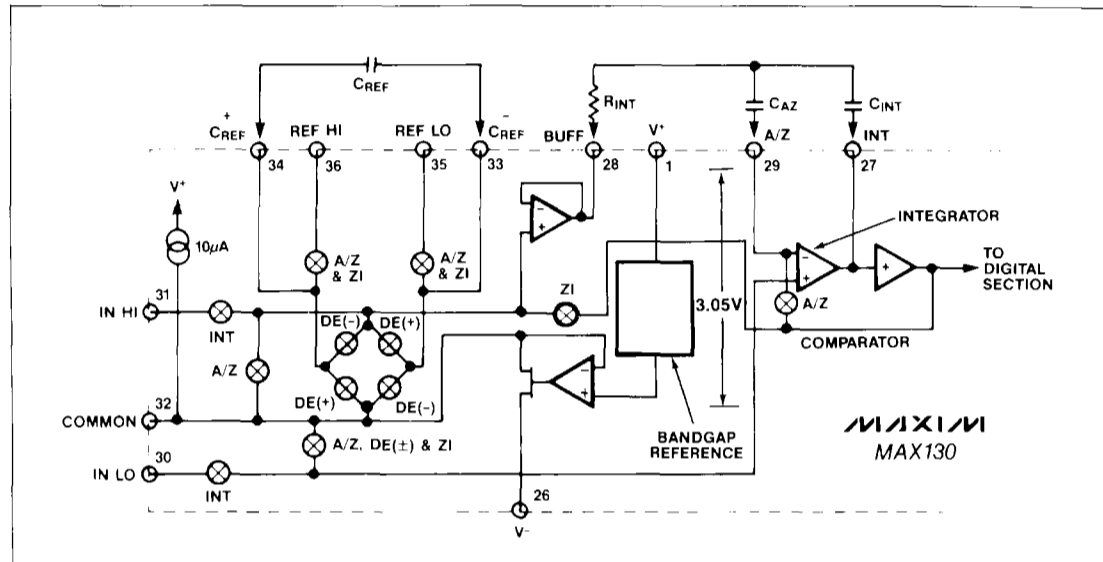

Figure 3. Analog Section of MAX130

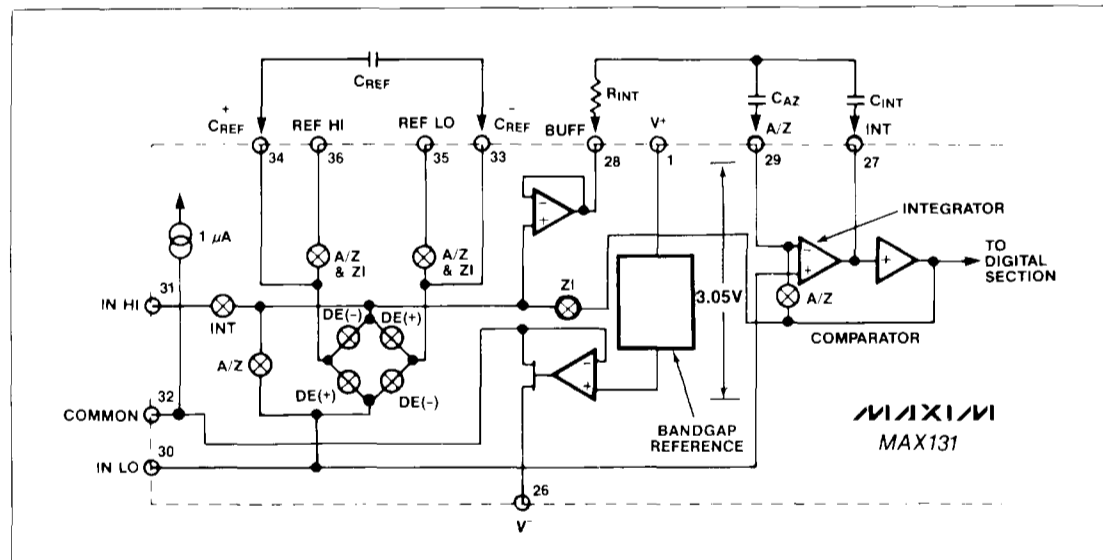

Figure 4. Analog Section of MAX131

## 3½ Digit A/D Converters with Bandgap Reference

### Detailed Description Conversion Method

The MAX130 and MAX131 use the dual-slope integration method of conversion, with the addition of an autozero phase to compensate for the offset of the buffer and integrator, and the addition of a zero integrator phase to ensure rapid recovery from an overrange conversion. Refer to the ICL7106 data sheet for a detailed description of the conversion phases and timing.

The conversion result is  $1000 \times (\ln \text{Hi} - \ln \text{Lo}) / (\text{Ref Hi} - \text{Ref Lo})$ , with a maximum conversion result of  $\pm 1999$ . If the input voltage is greater than full scale, the MAX130 and MAX131 will blank the lower three digits, and will display the leading "1" digit and, if the input voltage is negative, will also turn on the Minus segment.

### MAX130 and MAX131 Common Pin Voltage Reference

The Common voltage of the MAX130 and MAX131 is derived from a bandgap reference, unlike earlier devices which derive the Common voltage from a zener. The MAX130/131 bandgap reference eliminates the excessive long term drift associated with low current zeners, and the MAX130/131 can be a source of a high quality reference voltage without the use of external bandgap reference diodes. The MAX130/131 Common voltage does have slightly more wideband noise than does a zener-derived Common voltage, but a 0.1 $\mu$ F or greater reference capacitor will reduce the bandwidth sufficiently to virtually eliminate the noise.

The long term stability of the common voltage is approximately 0.01% (100ppm or 1/5 count). The temperature coefficient of the each MAX130A and MAX131A device is individually tested at 25°C, at the minimum operating temperature, and at the maximum operating temperature. The maximum allowable temperature coefficient from 25°C to either temperature extreme is 50ppm/°C. The MAX130 and MAX131 devices without the A suffix are sample tested to ensure a maximum temperature coefficient of 100ppm/°C.

The MAX130/131 Common voltage is buffered by an op amp which has an output impedance of 1 ohm and up to 2mA output sink current, and a short circuit current of approximately 35mA. The Common pin has a small pullup current of 1 $\mu$ A typical, and if desired it can be driven to a voltage more negative than its internally generated voltage by overpowering the pullup current source.

Since the MAX130/131 Common voltage is derived from a bandgap reference, it remains at a relatively constant voltage until  $V^+$  drops to less than 4V, unlike the ICL7106 and ICL7136 Common voltage which starts to fall once  $V^+$  drops to around 7V. The PSRR of Common is 0.1mV/V (80dB) typical for a  $V^+$  voltage change of 9V to 4.5V.

The Common voltage is trimmed to  $3.05V \pm 100mV$ . This is significantly more accurate than the 2.4V to 3.2V span allowed in the ICL7106. The better voltage accuracy allows the trim range of the reference voltage to be reduced, increasing resolution and ease of adjustment.

### MAX130 and MAX131 Test Voltage

The MAX130/131 internally generate a supply which is 4V to 6V below  $V^+$ . This voltage powers the digital logic section, including the LCD display driver section. This internal test voltage is coupled to the Test pin via a 500 ohm resistor. See Figure 5. Test pin is suitable for powering external low power CMOS circuitry such as the decimal point and annunciator driver circuits shown in Figure 6.

### Oscillator

The MAX130 and MAX131 oscillator circuit is shown in Figure 5. The oscillator is divided by 4 to generate the system clock, and each conversion takes 4000 system clock cycles or 16,000 oscillator cycles. The integration period is 1000 system clock cycles or 4000 oscillator cycles. For maximum rejection of normal mode AC signals the integration period should be an integer multiple of the interfering signal. A 40kHz oscillator frequency will reject both 50Hz and 60Hz since this sets the integration period equal to 6 cycles of 60Hz and 5 cycles of 50Hz. Either a 50pF or 100pF oscillator capacitor can be used and the resistor is calculated from the equation  $f \approx 0.40/RC$ .

### In Lo and In Hi Differential Inputs

These A/D converters measure the differential voltage between In Lo and In Hi. The MAX130 has a typical common mode rejection ratio (CMRR) of 86dB; while the MAX131 has a typical CMRR of 120dB.

In Hi has a guaranteed maximum input leakage current of only 10pA, and can be directly driven by high source impedances such as pH sensors and by the 10 Megohm input impedance attenuators normally used in digital multimeters. Both In Hi and In Lo have protection clamp diodes to  $V^+$  and  $V^-$ . If the input voltage can go above  $V^+$  or below  $V^-$  then the input currents should be limited to less than 1mA to prevent damage to the A/D.

The MAX130 and MAX131 common mode voltage range for In Hi and In Lo is a minimum of  $\pm 1V$  around Common. Under some circumstances, In Hi and In Lo can range from  $V^- + 1.5V$  to  $V^+ - 1.5V$ . See "Common Mode Voltage Range Considerations" section of the Application Notes for further information.

### Reference and $C_{REF}$ Pins

As shown in the analog block diagrams, Figures 3 and 4, Ref Hi and Ref Lo are connected to the  $C_{REF}$  pins during autozero and zero integrate phases via analog switches. This charges an external reference capacitor, which is then used as either a positive or a

## 3½ Digit A/D Converters with Bandgap Reference

MAX130/MAX131

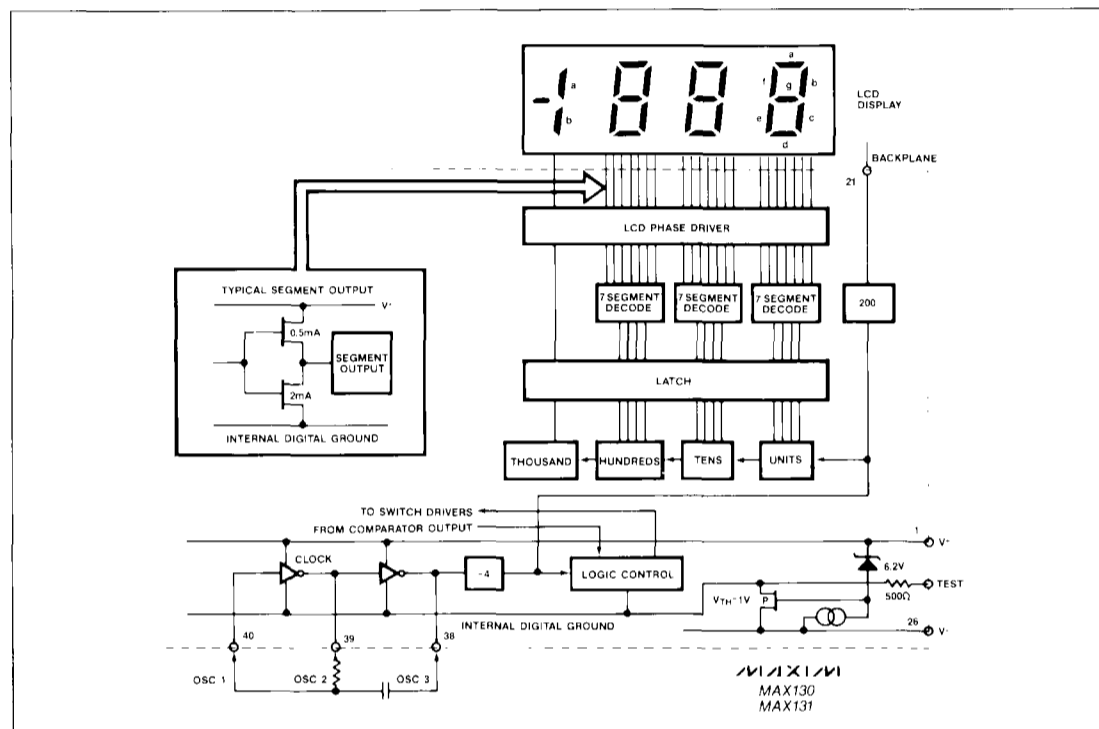

Figure 5. MAX130/131 Digital Section and Oscillator

negative reference voltage as needed during the de-integration phase. The common mode voltage range (CMVR) of Ref Hi and Ref Lo is  $V^+$  to  $V^-$ —any voltage between  $V^+$  and  $V^-$  can be used to drive the Ref Hi and Ref Lo inputs. The differential voltage between Ref Hi and Ref Lo sets the full scale voltage. A full scale output of  $\pm 1999$  counts occurs with an input voltage of  $\pm 1.999$  times the differential voltage between Ref Hi and Ref Lo. If the differential reference voltage is 1.0V the full scale input voltage is 1.999V. With 100mV reference the full scale input voltage is 199.9mV.

### LCD Display Driver Outputs

The MAX130 and MAX131 LCD display driver outputs swing from  $V^+$  to the Test pin voltage at a frequency 20 times the conversion rate (50Hz for an oscillator frequency of 40kHz and conversion rate of 2.5 times per second). The output impedance is approximately 3k $\Omega$ . The LCD display driver outputs are non-multiplexed or direct drive, and drive in-phase with the backplane output to turn an LCD segment off and drive 180° out of phase with the backplane output to turn an LCD segment on.

The BP or Backplane output has an output impedance of 500 $\Omega$ . The LCD drive waveforms are 50% duty cycle with matched rise and fall times to minimize the DC component across the LCD display.

### Component Selection

#### Integrator Resistor, $R_{INT}$

The MAX130 integrator and buffer amplifiers have a class A output stage which can deliver up to 6 $\mu$ A with high linearity. Normally, the MAX130 integrator resistor is chosen to set the maximum current to approximately 4 $\mu$ A by setting its value to  $2 \times V_{REF}/4\mu A$ . For a 1V reference the correct value is 470k $\Omega$ . For a 100mV reference the correct value is 47k $\Omega$ . Since the absolute value of  $R_{INT}$  does not affect the conversion accuracy, the type of resistor used for  $R_{INT}$  is not critical.

The MAX131 integrator and buffer also have up to 4 $\mu$ A of output current capability, with a maximum output current of 1.1 $\mu$ A being the recommended operating point. For 1V reference (2V full scale)  $R_{INT}$  should be 1.8M $\Omega$ . Use 180k $\Omega$  for  $R_{INT}$  when using a 100mV reference (200mV full scale).

#### Integrator Capacitor

The integrator capacitor is normally polypropylene, which has low dielectric absorption. Dielectric absorption will cause integral linearity errors. For example, if polyester or Mylar is used, the measured value of inputs near full scale will be approximately 0.1% lower than expected, while the measured value of low input voltages will be as expected.

### 3½ Digit A/D Converters with Bandgap Reference

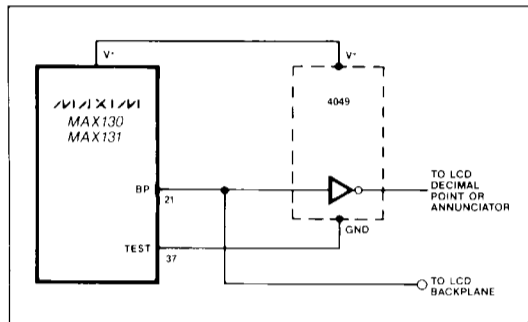

Figure 6A. Fixed Decimal Point Drivers

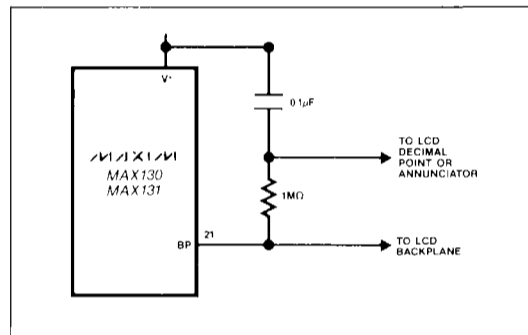

Figure 6B. Fixed Decimal Point Drivers

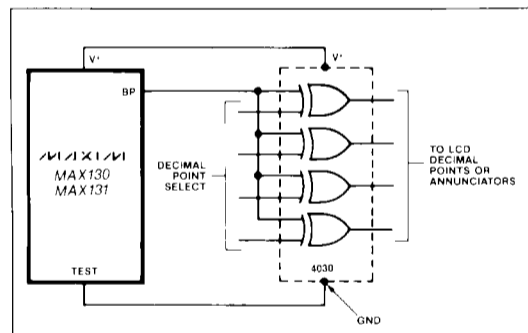

Figure 6C. Exclusive "OR" Gate for Decimal Point Drive

Proper selection of the integrator capacitor value can be verified by monitoring the output swing of the integrator with  $\pm$ full scale input voltages. In a properly operating circuit,  $\pm$ full scale input voltages will cause the integrator output (INT pin) to swing to about  $\pm 2V$ . The integrator output can drive to about 0.3V from either supply while maintaining high linearity. Integrator swing is inversely proportional to the oscillator frequency, so the integrator capacitor value must be increased in circuits with conversion rates less than 3 conversions per second.

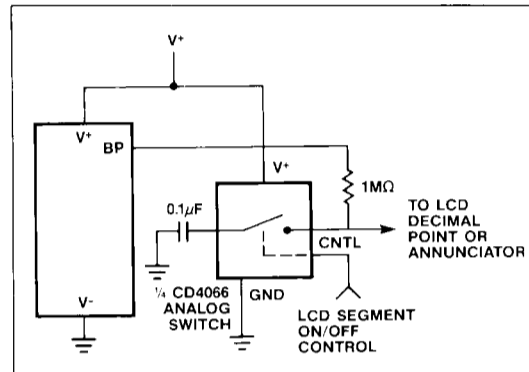

Figure 6D. Analog Switch for Decimal Point Drive

If the value of the integrator capacitor or integrator resistor is too low,  $\pm$ full scale inputs will cause the integrator to saturate as it attempts to drive above  $V^+$  or below  $V^-$ . If this occurs, operation will appear normal for low input voltages, but the conversion results for higher output voltages will be less than full scale.

Very low integrator swing will increase the amount of noise or "flicker" of the conversions. A full scale integrator swing of  $\pm 1V$  is sufficient to avoid any significant degradation of the noise performance, and should be used for operation with a 5V supply.

#### Reference Capacitor

For most circuits a reference capacitor value of  $0.1\mu F$  is adequate. However, a larger value is needed to prevent rollover error if there is significant stray capacitance at the reference capacitor terminals. Minimize the stray capacitance on the reference capacitor terminals to reduce the rollover error, and if necessary, increase the reference capacitor value to  $1.0\mu F$ .

The printed circuit board should be carefully cleaned to minimize leakage at the  $C_{REF}$  terminals since leakage will cause both gain and rollover errors. Due to the increased leakage of the MAX130 and MAX131 at  $+70^\circ C$ , a  $1.0\mu F$  reference capacitor is recommended to reduce rollover and gain errors at high temperature.

The reference capacitor is typically a low leakage film capacitor. Polyester (Mylar) is acceptable in applications where the reference voltage is constant. A low dielectric absorption capacitor such as polypropylene should be used if the reference voltage is variable, since any dielectric absorption will increase the settling time in response to a change in reference voltage. Since the reference voltage varies in circuits which measure resistance ratiometrically, a polypropylene reference capacitor should be used in ohmmeters.

#### Autozero Capacitor

The noise of the A/D is influenced by the autozero capacitor. For the best noise performance, an autozero capacitor value of at least 4 times the integrator



## 3½ Digit A/D Converters with Bandgap Reference

capacitor value is recommended. For a 2V scale, a 0.047 $\mu$ F (47nF) capacitor is adequate. An autozero capacitor of 0.47 $\mu$ F or greater is recommended for a 200mV full scale. All of Maxim's integrating A/D converters have a Zero Integrator phase which allows the use of high values for the autozero capacitor without causing hysteresis or slowing the overload recovery time.

The autozero capacitor can be any low leakage film capacitor in most applications. A low dielectric polypropylene capacitor is recommended if there are rapid changes in common mode voltage, or if the A/D must rapidly stabilize upon power-up.

### Oscillator Components, MAX130 and MAX131

For three conversions per second either use 100k $\Omega$  R<sub>OSC</sub> and a 100pF C<sub>OSC</sub>, or use a 180k $\Omega$  R<sub>OSC</sub> and a 50pF C<sub>OSC</sub>. The MAX130 test circuits show 100k $\Omega$ /100pF and the MAX131 test circuits show 180k $\Omega$ /50pF, but both A/Ds will operate correctly with either set of components. Other conversion rates can be set by changing the oscillator components. Each conversion takes 16,000 oscillator cycles, and the oscillator frequency is approximated by the equation  $f_{OSC} = 0.45/RC$ , where  $C = C_{OSC} + 5pF$ .

Typical part-to-part variation of oscillator frequency is  $\pm 5\%$ , and the typical variation with temperature is an decrease in frequency of 3% at 70°C, and an increase in frequency of 1% at 0°C. Normal mode rejection of 50Hz and 60Hz can be improved by driving the OSC1 pin with an external clock signal of precisely 40.00kHz. The OSC1 pin is the input of a CMOS inverter powered from V<sup>+</sup> and the Test pin voltage. Either drive OSC1 directly with a signal that swings from the Test voltage to V<sup>+</sup>, or drive it via an AC-coupled 2Vpk-pk to 5Vpk-pk signal.

### Application Notes

#### Common Mode Voltage Range Considerations

In many applications In Lo is connected to Common, and the supply voltage is greater than 6V. In these cases the common mode voltage range restrictions on In Hi and In Lo will not be a design consideration. On the other hand, operation with low supply voltages, or operation with either In Lo or In Hi near either supply calls for careful evaluation of the effect of common mode voltages.

Table 1. Common Mode Voltage Limits

DEVICE	IN HI	IN LO	INTEGRATOR SWING
MAX130 with Positive Input Voltages	V <sup>-</sup> + 1.5V to V <sup>+</sup> - 1.5V	V <sup>-</sup> + 1.5V to V <sub>COMMON</sub> + 1.0V	(In Lo - V <sup>-</sup> ) or (V <sub>COMMON</sub> - V <sup>-</sup> ), whichever is smaller.
MAX130 with Negative Input Voltages	V <sup>-</sup> + 1.5V to V <sup>+</sup> - 1.5V	V <sup>-</sup> + 1.5V to V <sup>+</sup> - 1.5V	(V <sup>-</sup> - In Lo) or (V <sup>+</sup> - V <sub>COMMON</sub> ), whichever is smaller.
MAX131 with Positive Input Voltage	V <sup>-</sup> + 1.5V to V <sup>+</sup> - 1.5V	V <sup>-</sup> + (1.5V + V <sub>REF</sub> ) to V <sup>+</sup> - 1.5V	(In Lo - V <sup>-</sup> )
MAX131 with Negative Input Voltage	V <sup>-</sup> + 1.5V to V <sup>+</sup> - 1.5V	V <sup>-</sup> + 1.5V to V <sup>+</sup> - (1.5V + V <sub>REF</sub> )	(V <sup>-</sup> - In Lo)

Since the MAX131 performs all conversion phases, including autozero and deintegration, using In Lo as the reference point, the MAX131 has excellent common mode rejection of approximately 120dB. The MAX130 uses the Common voltage as the reference point for autozero and deintegration and the common mode rejection ratio of the MAX130 is about 86dB.

There are four basic internal limitations on the allowable common mode voltage (see Figures 3 and 4):

- 1) The buffer input CMVR is (V<sup>-</sup> + 1.5V) to (V<sup>+</sup> - 1.5V).
- 2) The integrator CMVR is (V<sup>-</sup> + 1.5V) to (V<sup>+</sup> - 1.5V).
- 3) The integrator output swing is limited to V<sup>-</sup> to V<sup>+</sup>.
- 4) The MAX130 In Lo must not go more than 1.0V above Common.

Figure 3 shows that the MAX130 buffer input can be connected to either In Hi, (Common + V<sub>REF</sub>), or (Common - V<sub>REF</sub>), where V<sub>REF</sub> is the differential reference voltage between Ref Hi and Ref Lo and is independent of the Common voltage at Ref Hi and Ref Lo. Further inspection shows that the integrator is connected either to In Lo (during Integrate) or Common (during deintegrate).

Figure 4 shows that the MAX131 buffer input can be connected to either In Hi, (In Lo + V<sub>REF</sub>), or (In Lo - V<sub>REF</sub>). The integrator non-inverting input is always connected to In Lo.

Combining the four system CMVR limitations with the possible connections results in the limitations shown in Table 1.

#### Operation with Low Supply Voltages

Unlike the ICL7106 and ICL7136 which use a 6V to 7V zener to generate their Common voltage, the MAX130 and MAX131 use a bandgap reference. Therefore the MAX130 and MAX131 generate an accurate Common voltage with supply voltages as low as 4.5V. Operation with a 5V supply, though, does require attention to both the common mode voltage range of the buffer, and the output swing limitations of the integrator. In particular, the input common mode voltage range does not include the negative supply voltage. Maxim's MAX138, which includes a charge pump voltage inverter and requires only slight circuit modifications of a MAX130/ICL7106 circuit, is recommended for +5V single supply applications where a ground-referred signal is to be measured.

## 3½ Digit A/D Converters with Bandgap Reference

Figure 7 shows typical components for +5V single supply MAX130/131 operation with a 200mV full scale range. Since the common voltage is 3.05V below  $V^+$ , it is less than 2V above ground. This means that the integrator swing must be reduced by increasing the value of the integrator capacitor. The value shown will result in about 1V to 1.5V integrator swing.

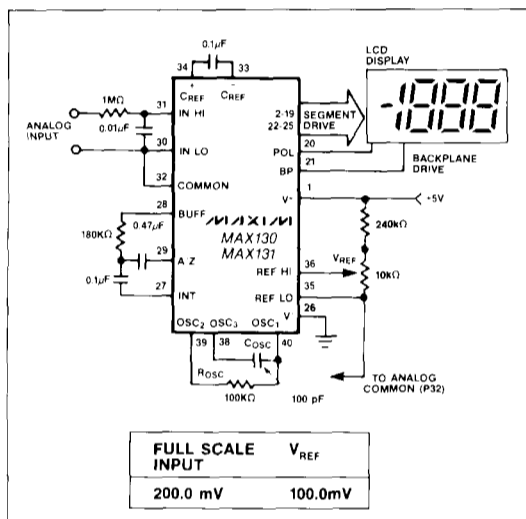

Figure 7. Single Supply +5V Operation

The voltage at the buffer input must stay in the common mode voltage range of  $(V^- + 1.5V)$  to  $(V^+ - 1.5V)$ . With the maximum common voltage of 3.15 and a full scale negative input of -200mV, this limit is met with a 4.85V or greater supply.

With a 2V full scale, the input buffer will exceed its negative common mode voltage range when a -2V input is applied with less than 6.7V supply voltage.

### Operation on ±5V Supplies

The MAX130/131 can easily be used with ±5V supplies. Connect  $V^+$  to +5V,  $V^-$  to -5V. If the voltages to be measured are referred to ground, then connect In Lo to ground. In most cases, Ref Hi and Ref Lo should be connected to a resistive divider string between  $V^+$  and Common, as shown in the standard application circuits of Figures 1 and 2. If Common is not used to generate the reference it can either be left floating or can be connected to ground. If the MAX130/131 oscillator is driven by 5V logic, or if the MAX130/131 LCD outputs drive 5V logic, then connect the Test pin to ground. If the MAX130/131 open circuit Test voltage is above ground, then connecting Test pin to ground will set the internal digital ground to approximately ground. If, however, the open circuit Test voltage is negative, additional  $V^+$  supply current will be drawn, and the LCD segments will continue to swing

below ground. The OSC1 pin, however, will respond to a voltage swing of 0V to 5V in either case.

### Low Battery Detector Circuit

Since the voltage between Common and  $V^+$  is between 2.95V and 3.15V until the voltage between  $V^+$  and  $V^-$  falls to less than 4V, a simple low battery detector can be made using a transistor voltage detector as shown in Figure 8. When Q2 is off the Low Battery segment is driven in phase with the backplane and is off. When Q1 and Q2 turn on, the Low Battery segment is held approximately midway between the Test voltage and  $V^+$ , and the Low Battery LCD segment becomes visible. Q1 and Q2 turn on when the voltage at the base of Q1 is one base-emitter voltage more positive than Common voltage. With the 4.7MΩ/4.7MΩ divider shown, this occurs when the battery voltage is approximately 6V. Decrease the value of R1 to lower the battery detection voltage.

A similar circuit using only one transistor can be made using the Test pin as the reference voltage rather than Common. Since the Test pin voltage may range from 4V to 6V, the low battery detection voltage when using the Test pin as a reference is not as accurate as Figure 8, which uses the Common voltage as the reference.

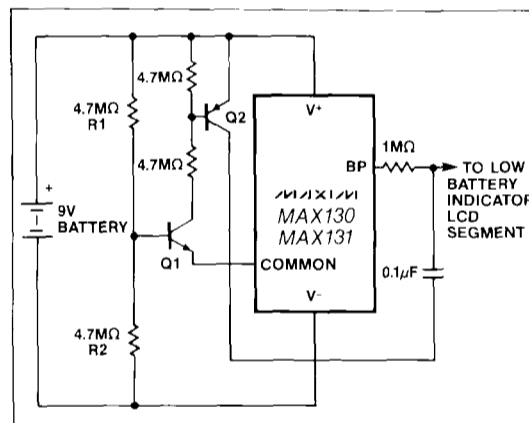

Figure 8. Low Battery Detector and LCD Segment Drive

## Common Problems and Their Solutions

### Erratic, Unpredictable Readings

Make sure that In Lo is connected to Common. Leaving both In Lo and In Hi floating with respect to Common and the power supplies will cause erratic readings since In Lo and In Hi will unpredictably float from  $V^+$  to  $V^-$  unless a DC connection between either In Lo or In Hi and Common is provided.

Look at the INT (pin 27 of the 40 pin DIP) with an oscilloscope. With 0V input the INT pin should be at approximately the same voltage as the In Lo pin.

## 3½ Digit A/D Converters with Bandgap Reference

With a full scale input voltage the INT pin voltage should be a triangular waveform. If no triangular waveform is seen, or if it is not in the 2Hz to 4Hz frequency range, then review the oscillator circuit connections and components to make sure they are correct.

### Overload Display

The least significant three digits are blanked if the input voltage exceeds full scale. The leading "1" is displayed for positive overloads, and a "-1" is displayed for negative overloads. Any of the conditions that cause erratic readings as discussed above may cause overload readings. In addition, check the differential voltage between In Hi and In Lo and make sure that it is no more than twice the differential voltage between Ref Hi and Ref Lo. Also make sure that the voltage at Ref Hi is more positive than the voltage at Ref Lo, since incorrect reference polarity will always cause an overload reading.

### Gross Nonlinearity

If the results are linear for low input voltages, but the displayed result stops increasing as higher input voltages are applied, then the most likely cause is saturation of the integrator output. With a full scale voltage applied, look at the voltage on the INT pin. It should not come closer than 0.3V to either supply. Increase the integrator capacitor value if the INT output swing is excessive. Alternatively, increase the oscillator frequency by changing the oscillator resistor and capacitor values.

### Nonlinearities of 2 to 20 Counts

A polyester (Mylar) integrator capacitor will result in about 2 or 3 counts of nonlinearity at full scale. Use polypropylene for best linearity. Leakages into the integrator capacitor, the autozero capacitor, or the reference capacitor will also cause linearity errors. Make sure that printed circuit boards are thoroughly cleaned after soldering.

### Gain Error and Rollover Error

A gross gain error will result if the integrator output current capabilities are exceeded. Make sure that  $R_{INT} \geq V_{REF}/2.5\mu A$  for the MAX130, and  $\geq V_{REF}/0.6\mu A$  for the MAX131.

Gain errors less than ten counts are generally caused by either too much stray capacitance on the  $C_{REF}$  terminals, or by excessive printed circuit board leakage. Stray capacitance and leakage can be detected by reducing the reference capacitor by a factor of ten. If the error dramatically increases, then either stray capacitance or leakage at the reference capacitor terminals is the culprit. Error caused by stray capacitance tend to be a pure gain error, while errors due to leakage tend to be nonlinear—typically square law. Errors due to leakage can also be detected by cleaning the board, then baking to reduce moisture content.

### Offset Errors, or Non-Zero Reading with 0V Input

This type of error is most often caused by leakages

into the input pins, the integrator capacitor, or the autozero capacitor.

A very high clock rate can also make the MAX130 and particularly the MAX131 show  $\pm 001$  with 0V input. Either return the oscillator frequency to the standard 40 or 48kHz range, or if a higher clock frequency must be used, then put a resistor of a few hundred ohms in series with the integration capacitor.

The MAX130/131 have better performance with low integrator swing than do the ICL7106 or ICL7136, but extremely low integrator swing may still result in a non-zero reading with 0V input. Increase integrator swing to at least  $\pm 0.5V$  with a  $\pm$ full scale input, with  $\pm 2V$  swing being preferred.

### Missing Segments on the LCD Display

This is very, very rarely a problem of the MAX130/131. More often it is caused by open circuits in the LCD connector/bezel, particularly if an elastomeric connector (zebra strip) is used. Check the voltage waveform at the pins of the MAX130/131. A signal in-phase with the backplane turns off an LCD segment, a signal 180° out of phase from the backplane turns on an LCD segment.

### Noisy Readings

The most common reason for noisy readings, particularly in engineering labs, is simply that the input signal is noisy. The  $1M\Omega/10nF$  input filter shown in Figures 1 and 2 will significantly reduce high frequency noise, and the capacitor value can be increased to further attenuate 50/60Hz.

If the input signal is clean, then the next thing to check is integrator swing since low integrator swing will increase the noise. If the integrator swing must be reduced to less than 1V for some reason, then increasing the value of the autozero capacitor will improve the noise performance. For most circuits, the integrator swing should be approximately  $\pm 2V$ .

A very low value for the autozero capacitor will also make the readings noisy. The value of the autozero capacitor should be at least twice the value of the integration capacitor, and increasing the autozero capacitor value to between 4 and 10 times that of the integrator capacitor will improve the noise performance, particularly with low reference voltages.

Stray coupling of noise signals, either digital/microprocessor noise or 50/60Hz and 100/120Hz ripple can also be a cause of noisy readings. The circuit area most likely to pick up stray signals is the autozero capacitor. The distance between the autozero capacitor and the AZ pin should be minimized, as should the distance between the autozero capacitor and the integration resistor and capacitor. If possible, use a ground plane around the sensitive analog section that includes  $C_{INT}$ ,  $C_{AZ}$ , and  $R_{INT}$ . Since the BUFF and INT pins are the outputs of op amps, they are less sensitive to noise pick-up than is the AZ pin, which is the input of an op amp. Orient the integration capacitor such that its outer foil is connected to the INT pin.

### 3½ Digit A/D Converters with Bandgap Reference

The MAX131, unlike the MAX130, is sensitive to AC noise at In Lo during the de-integrate phase. In particular, full wave AC-DC converters should be used with the MAX131 only if both outputs of the AC-DC converter output are well filtered.

The Common outputs of the MAX130 and MAX131, being derived from a bandgap reference, are noisier than the ICL7106 and ICL7136 Common outputs, which are derived from zeners. This could cause an increase in conversion noise, but only if the C<sub>REF</sub> is less than 0.1µF, and there is no bypassing at the reference inputs.

Poor bypassing of the supply voltage may cause a couple of counts of noise in the readings, particularly if the power supply also powers digital logic, since high frequency spikes on the power supply might cause the comparator to falsely indicate zero crossing one or two clock cycles early. Ordinary 0.1µF bypass capacitors are adequate in most cases. Since the MAX130 and MAX131 draw very little current, a simple RC filter can be used to provide greater spike and ripple attenuation in those cases where the power supply is exceptionally noisy.

Since the oscillator frequency is slightly affected by the supply voltage, large changes in the supply voltage during a conversion may cause a few counts of error. A typical case where the effect must be considered is in a battery powered circuit where the battery is also being used to drive high current loads such as motors or lamps. For extreme cases where high current loads momentarily change the battery voltage a volt or more, use a series diode and a capacitor of 10µF or greater.

#### Application Hints

1. See the ICL7136 and ICL7106 data sheets for a variety of application circuits which can also be used with the MAX130 and MAX131.
2. In some applications it may be useful to apply a fixed reference voltage between In Hi and In Lo, and to apply the signal to Ref Hi and Ref Lo. In this mode of operation the displayed reading is inversely proportional to the input voltage. In other words, the displayed reading is the result of *dividing* the fixed reference voltage by the signal voltage. A typical application where this function is useful is in an RPM meter, where a voltage proportional to the period of a signal is divided into a fixed voltage to convert period into RPM (frequency). Another example is in a conductance meter, where the conversion between ohms and Siemens is performed by swapping the positions of the unknown and reference resistors.
3. A serial output pulse stream can be obtained from the MAX130/131 by monitoring the voltage at the C<sub>REF</sub> terminals as shown in the circuit of Figure 23 in the ICL7106 data sheet. Use an AND gate to combine the resulting End-of-Conversion signal with the oscillator output from OSC3, pin 38.

4. If the input signal polarity is reversed from the desired polarity, then use the "Minus" segment to drive the vertical bar of a plus sign, and permanently turn on the horizontal bar of the plus sign using one of the decimal point driver circuits of Figure 6. When the MAX130/131 measures a negative polarity, a "+" will be displayed. When the MAX130/131 measures a positive polarity, then a "-" will be displayed. (Normal operation of the MAX130/131 is no polarity indication for a positive input, and a "-" sign for a negative input.)
5. It is not normally practical to multiplex one LCD display between a MAX130/131 and another IC, since this requires an analog switch in series with every LCD segment. One design alternative is to convert all signals to pulse streams (see #3, above), then to multiplex the pulse streams into a counter/LCD driver such as the ICM7224. Another alternative is to use a BCD output A/D converter such as the ICL7135 in combination with the ICM7211 display driver.

#### Ordering Information (Continued)

PART	TEMP. RANGE	PACKAGE
MAX131C/D	0°C to +70°C	Dice
MAX131EPL	-40°C to +85°C	40 Lead Plastic DIP
MAX131EQH	-40°C to +85°C	44 Lead Plastic Chip Carrier
MAX131ACPL	0°C to +70°C	40 Lead Plastic DIP
MAX131ACQH	0°C to +70°C	44 Lead Plastic Chip Carrier
MAX131AEPL	-40°C to +85°C	40 Lead Plastic DIP
MAX131AEQH	-40°C to +85°C	44 Lead Plastic Chip Carrier

#### Pin Configuration

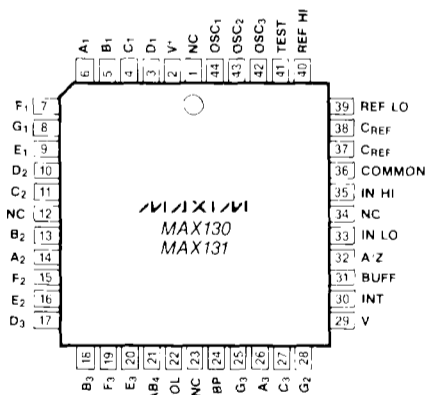

44 Lead Plastic Chip Carrier (Quad Pack)

Maxim cannot assume responsibility for use of any circuitry other than circuitry entirely embodied in a Maxim product. No circuit patent licenses are implied. Maxim reserves the right to change the circuitry and specifications without notice at any time.