

MAXIM

Ultra Low Offset Voltage Operational Amplifier

MAX400

General Description

The MAX400 guaranteed maximum $10\mu\text{V}$ offset error is the lowest input offset voltage of any commercially available (nonchopper) monolithic amplifier. The MAX400 represents a 2.5 times improvement over the highest grade OP07 (the OP07A), and a 5 times improvement over the best commercial temperature range device (OP07E). The offset voltage drift is guaranteed to be a maximum of $0.3\mu\text{V}/^\circ\text{C}$ which is also an improvement over the OP07 family.

For the ultimate in DC performance ($5\mu\text{V}$ maximum offset voltage and $0.05\mu\text{V}/^\circ\text{C}$ maximum offset voltage drift) the MAX420 and MAX430 series of $\pm 15\text{V}$ monolithic chopper stabilized amplifiers should be consulted.

Features

- ◆ Ultra Low Offset Voltage: $10\mu\text{V}$ (max.)
- ◆ Ultra Low Offset Voltage Drift: $0.2\mu\text{V}/^\circ\text{C}$
- ◆ Ultra Stable vs. Time: $0.2\mu\text{V}/\text{Month}$
- ◆ Ultra Low Noise $0.35\mu\text{V}_{\text{p-p}}$
- ◆ Wide Supply Voltage: $\pm 3\text{V}$ to $\pm 18\text{V}$
- ◆ High Common Mode Input: $\pm 14\text{V}$
- ◆ No External Components Required
- ◆ Fits OP07, AD510, 725, 108A/308A Sockets

Applications

- Precision Amplifiers
- Thermocouple Amplifiers
- Low Level Signal Processing
- Medical Instrumentation
- Strain Gauge Amplifiers
- High Accuracy Data Acquisition

Ordering Information

PART	TEMP. RANGE	PACKAGE
MAX400MJA	-55°C to $+125^\circ\text{C}$	8 Lead CERDIP
MAX400MTV	-55°C to $+125^\circ\text{C}$	8 Lead TO-99
MAX400EJA	-40°C to $+85^\circ\text{C}$	8 Lead CERDIP
MAX400ETV	-40°C to $+85^\circ\text{C}$	8 Lead TO-99
MAX400CTV	0°C to $+70^\circ\text{C}$	8 Lead TO-99
MAX400CPA	0°C to $+70^\circ\text{C}$	8 Lead Plastic DIP
MAX400CSA	0°C to $+70^\circ\text{C}$	8 Lead Small Outline

Pin Configuration

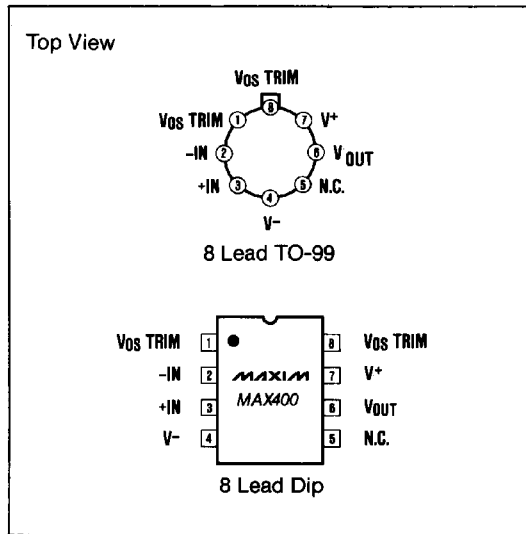

Typical Operating Circuit

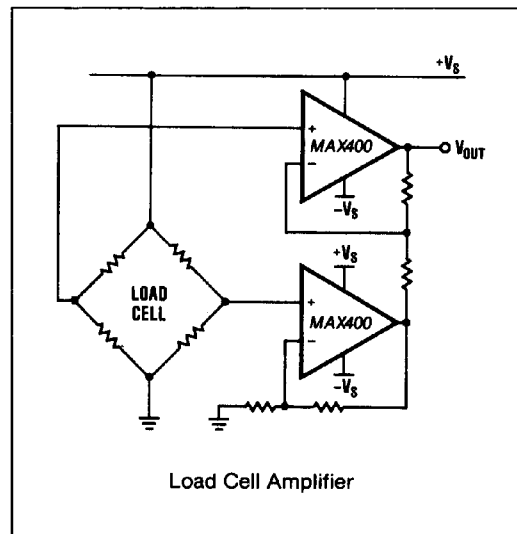

Ultra Low Offset Voltage Operational Amplifier

ABSOLUTE MAXIMUM RATINGS

Total Supply Voltage (V^+ to V^-)	±22V	Operating Temperature Range	
Internal Power Dissipation	500mW	MAX400M	-55°C to +125°C
TO-99(T) — derate at 7.1mW/°C above +80°C		MAX400E	-40°C to +85°C
Hermetic Dip(J) — derate at 6.7mW/°C above +75°C		MAX400C	0°C to +70°C
Plastic Dip(P) — derate at 5.6mW/°C above +38°C		Lead Temperature (Soldering, 10 sec)	+300°C
Differential Input Voltage	±30V	Duration of Output Short Circuit	Indefinite
Input Voltage (Note 1)	±22V	Junction Temperature (T_J)	-65°C to +160°C
Storage Temperature Range	-65°C to +150°C		

Note 1: For supply voltages less than ±22V, the absolute maximum input voltage is equal to the supply voltage.

Stresses above those listed under "Absolute Maximum Ratings" may cause permanent damage to the device. These are stress ratings only and functional operation of the device at these or any other conditions above those indicated in the operational sections of the specifications is not implied. Exposure to absolute maximum rating conditions for extended periods may affect device reliability.

ELECTRICAL CHARACTERISTICS

($V_S = \pm 15V$, $T_A = +25^\circ C$, unless otherwise noted.)

PARAMETER	SYMBOL	CONDITIONS	MAX400M			MAX400C/E			UNITS
			MIN	TYP	MAX	MIN	TYP	MAX	
Input Offset Voltage	V_{OS}	(Note 2)		4	10		10	15	μV
Long Term Input Offset Voltage Stability	V_{OS}/Time	(Note 3)		0.2	1.0		0.2	1.0	$\mu V/\text{Month}$
Input Offset Current	I_{OS}			0.3	2.0		0.3	2.0	nA
Input Bias Current	I_B			±0.7	±2.0		±0.7	±2.0	nA
Input Noise Voltage	$e_{N\text{ P-P}}$	0.1Hz to 10Hz (Note 4)		0.35	0.6		0.35	0.6	$\mu V_{\text{P-P}}$
Input Noise Voltage Density	e_N	$f_O = 10\text{Hz}$ (Note 4)		10.3	18.0		10.3	18.0	$nV/\sqrt{\text{Hz}}$
		$f_O = 100\text{Hz}$ (Note 4)		10.0	13.0		10.0	13.0	
		$f_O = 1000\text{Hz}$ (Note 4)		9.6	11.0		9.6	11.0	
Input Noise Current	$I_{N\text{ P-P}}$	0.1Hz to 10Hz (Note 4)		14	30		14	30	$\text{pA}_{\text{P-P}}$
Input Noise Current Density	I_N	$f_O = 10\text{Hz}$ (Note 4)		0.32	0.80		0.32	0.80	$\text{pA}/\sqrt{\text{Hz}}$
		$f_O = 100\text{Hz}$ (Note 4)		0.14	0.23		0.14	0.23	
		$f_O = 1000\text{Hz}$ (Note 4)		0.12	0.17		0.12	0.17	
Input Resistance Differential-Mode	R_{IN}	(Note 5)	30	80		20	60	$M\Omega$	
Input Resistance Common-Mode	R_{INCM}			200			200	$G\Omega$	
Input Voltage Range	IVR		±13	±14		±13	±14	V	
Common-Mode Rejection Ratio	CMRR	$V_{CM} = \pm 13V$	114	126		114	126	dB	
Power Supply Rejection Ratio	PSRR	$V_S = \pm 3V$ to $\pm 18V$		4	10		4	10	$\mu V/V$
Large Signal Voltage Gain	A_{VO}	$R_L \geq 2k\Omega, V_O = \pm 10V$	500	1000		500	1000	V/mV	
		$R_L \geq 500\Omega, V_O = \pm 0.5V$	150	400		150	400		
Output Voltage Swing	V_O	$R_L \geq 10k\Omega$	±12.5	±13.0		±12.5	±13.0	V	
		$R_L \geq 2k\Omega$	±12.0	±12.8		±12.0	±12.8		
		$R_L \geq 1k\Omega$	±10.5	±12.0		±10.5	±12.0		

Note 2: V_{OS} is measured one minute after application of power.

Note 3: Long-Term Input Offset Voltage Stability refers to the average trend line of V_{OS} vs. Time over extended periods after the first 30 days of operation. Excluding the initial hour of operation, changes in V_{OS} during the first 30 operating days are typically $2.5\mu V$ — refer to typical performance curves. Parameter is sample tested.

Note 4: Sample tested.

Note 5: Guaranteed by design.

Ultra Low Offset Voltage Operational Amplifier

MAX400

ELECTRICAL CHARACTERISTICS (continued)

($V_S = \pm 15V$, $T_A = +25^\circ C$, unless otherwise noted.)

PARAMETER	SYMBOL	CONDITIONS	MAX400M			MAX400C/E			UNITS
			MIN	TYP	MAX	MIN	TYP	MAX	
Slew Rate	SR	$R_L \geq 2k\Omega$ (Note 6)	0.1	0.3		0.1	0.3		$V/\mu S$
Closed-Loop Bandwidth	BW	$A_{VCL} = +1V$ (Note 6)	0.4	0.6		0.4	0.6		MHz
Open-Loop Output Resistance	R_O	$V_O = 0V$, $I_O = 0$		60			60		Ω
Power Consumption	P_D	$V_S = \pm 15V$, No Load $V_S = \pm 3V$, No Load		75 4	120 6		75 4	120 6	mW
Offset Adjustment Range		$R_p = 20k\Omega$		± 4			± 4		mV

Note 6: Sample tested.

ELECTRICAL CHARACTERISTICS

($V_S = \pm 15V$, $T_A =$ Full Operating Temperature Range, unless otherwise noted.)

PARAMETER	SYMBOL	CONDITIONS	MAX400M			MAX400C/E			UNITS
			MIN	TYP	MAX	MIN	TYP	MAX	
Input Offset Voltage	V_{OS}	(Note 7)		20	40		20	40	μV
Average Temperature Coefficient of Input Offset Voltage	TCV_{OS}	(Note 8)		0.2	0.3		0.2	0.3	$\mu V/^\circ C$
Input Offset Current	I_{OS}			0.8	4.0		0.8	4.0	nA
Average Input Offset Current Drift	TCI_{OS}	(Note 9)		5	25		5	25	$pA/^\circ C$
Input Bias Current	I_B			± 1.0	± 4.0		± 1.0	± 4.0	nA
Average Input Bias Current Drift	TCI_B	(Note 9)		8	25		8	25	$pA/^\circ C$
Input Voltage Range	IVC		± 13	± 13.5		± 13	± 13.5		V
Common-Mode Rejection Ratio	CMRR	$V_{CM} = \pm 13V$	106	123		106	123		dB
Power Supply Rejection Ratio	PSRR	$V_S = \pm 3V$ to $\pm 18V$		5	20		5	20	$\mu V/V$
Large Signal Voltage Gain	A_{VO}	$R_L \geq 2k\Omega$, $V_O = \pm 10V$	200	400		200	400		V/mV
Output Voltage Swing	V_O	$R_L \geq 2k\Omega$	± 12.0	± 12.6		± 12.0	± 12.6		V

Note 7: Offset Voltage is measured one minute after application of power.

Note 8: 100% tested.

Note 9: Sample tested.

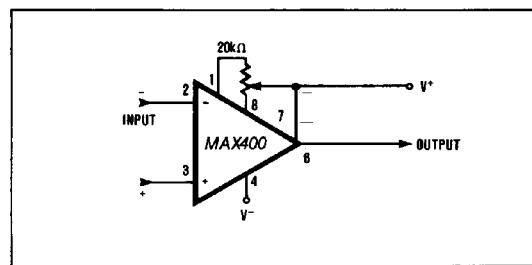

Figure 1. Optional Offset Nulling Circuit.

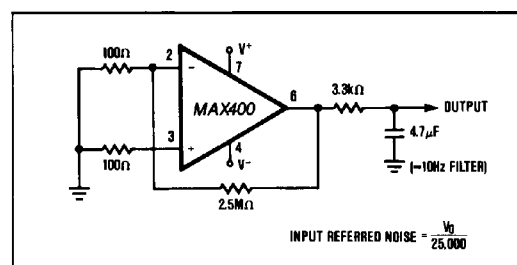
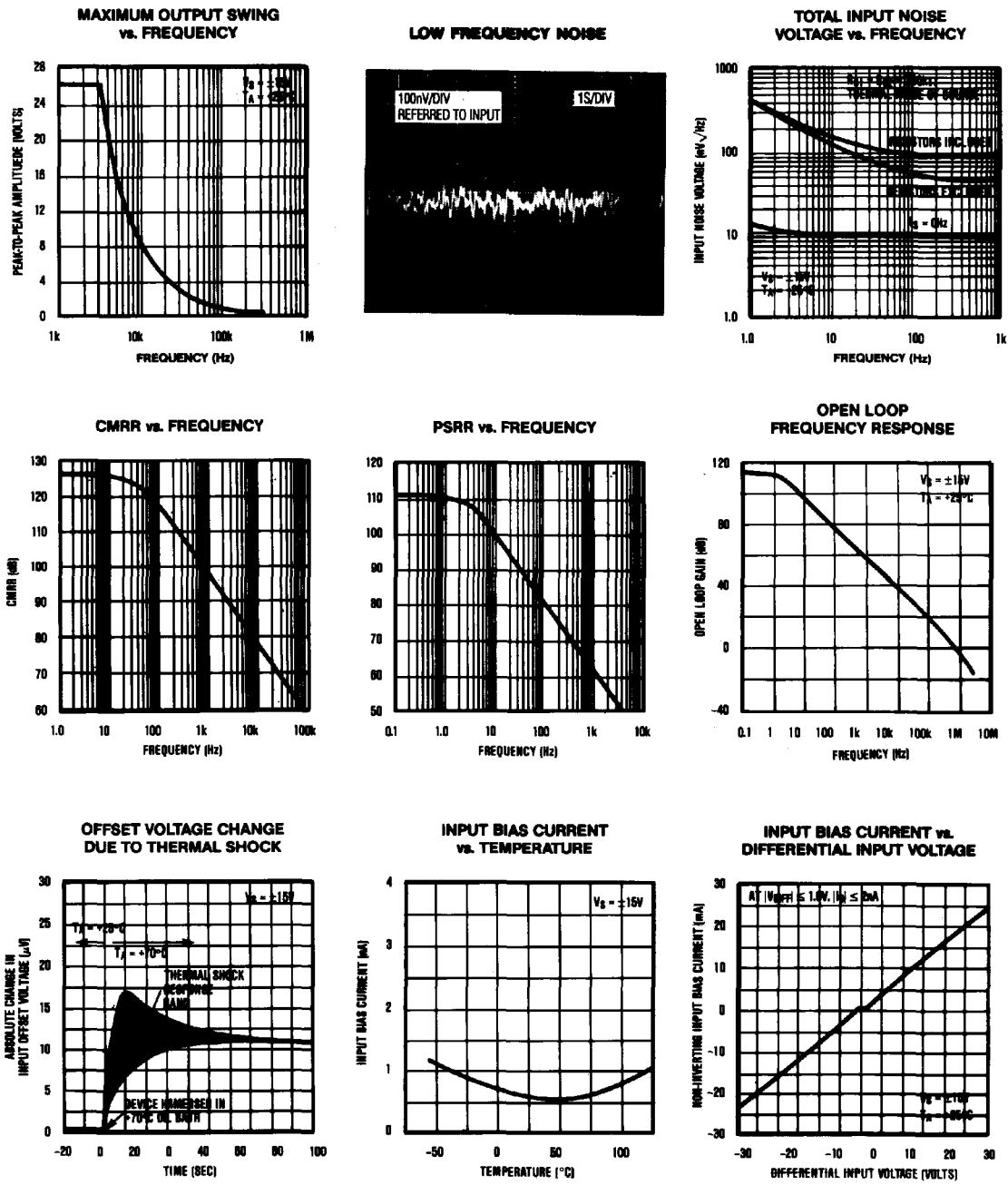

Figure 2. Low Frequency Noise Test Circuit.

Ultra Low Offset Voltage Operational Amplifier

Typical Operating Characteristics



Maxim cannot assume responsibility for use of any circuitry other than circuitry entirely embodied in a Maxim product. No circuit patent licenses are implied. Maxim reserves the right to change the circuitry and specifications without notice at any time.

4 Maxim Integrated Products, 120 San Gabriel Drive, Sunnyvale, CA 94086 (408) 737-7600

© 1994 Maxim Integrated Products

Printed USA

MAXIM is a registered trademark of Maxim Integrated Products.