

MAXIM

Preset/Adjustable Output CMOS Inverting Switching Regulators

MAX635/636/637

General Description

The MAX635/MAX636/MAX637 inverting switching regulators are designed for minimum component DC-DC conversion in the 5mW to 500mW range.

Low power applications require only a diode, output filter capacitor, and a low-cost inductor. An additional MOSFET and driver are needed for higher power applications. Low battery detection circuitry is included on chip.

The MAX635/636/637 are preset for -5V, -12V, and -15V outputs, respectively. However, the regulators can be set to other levels by adding 2 resistors.

Maxim manufactures a broad line of step-up, step-down, and inverting DC-DC converters, with features such as logic-level shutdown, adjustable oscillator frequency, and external MOSFET drive.

Applications

- Minimum Component, High-Efficiency DC-DC Converters
- Portable Instruments
- Battery Power Conversion
- Board Level DC-DC Conversion

Features

- ◆ Preset -5V, -12V, -15V Output Voltages
- ◆ Adjustable Output with 2 Resistors
- ◆ 85% Typ Efficiency
- ◆ Only 3 External Components
- ◆ 80 μ A Typ Operating Current
- ◆ Low Battery Detector

Ordering Information

PART*	TEMP. RANGE	PIN-PACKAGE
MAX635XCPA	0 C to +70 C	8 Plastic DIP
MAX635XCSA	0 C to +70 C	8 Narrow SO
MAX635XC/D	0 C to +70 C	Dice
MAX635XEPA	-40 C to +85 C	8 Plastic DIP
MAX635XESA	-40 C to +85 C	8 Narrow SO
MAX635XEJA	-40 C to +85 C	8 CERDIP
MAX635XMJA	-55 C to +125 C	8 CERDIP
MAX636XCPA	0 C to +70 C	8 Plastic DIP
MAX636XCSA	0 C to +70 C	8 Narrow SO
MAX636XC/D	0 C to +70 C	Dice
MAX636XEPA	-40 C to +85 C	8 Plastic DIP
MAX636XESA	-40 C to +85 C	8 Narrow SO
MAX636XEJA	-40 C to +85 C	8 CERDIP
MAX636XMJA	-55 C to +125 C	8 CERDIP

*X = A for 5% Output Accuracy, X = B for 10% Output Accuracy.
Ordering Information continued on last page.

Pin Configuration

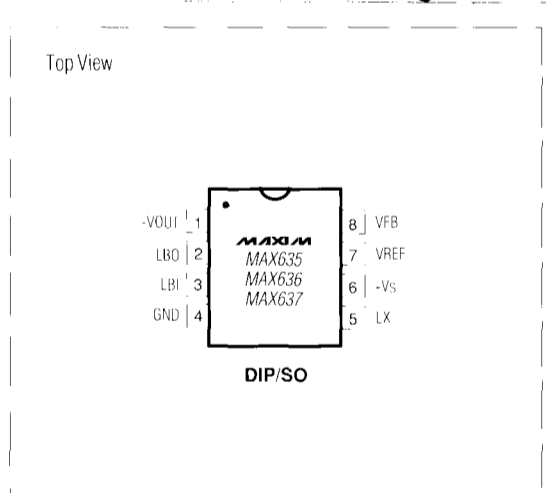

Typical Operating Circuit

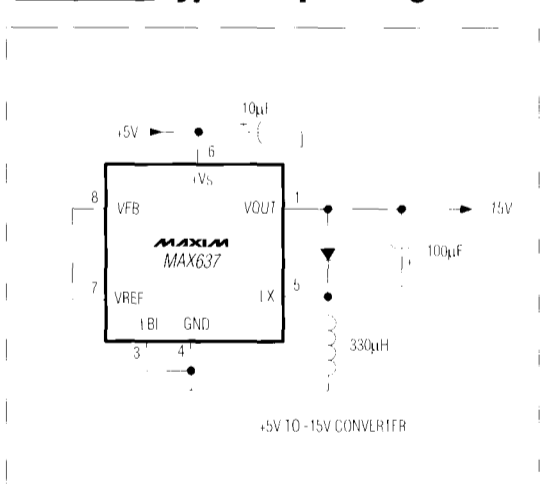

Preset/Adjustable Output CMOS Inverting Switching Regulators

ABSOLUTE MAXIMUM RATINGS

Supply Voltage, +Vs (Note 1)	+18V	Operating Temperature Range	0 C to +70 C
Input Voltage, LBO, LBI, VFB	-0.3V to (+Vs + 0.3V)	MAX63__C	-40 C to +85 C
LX Output Current	525mA Peak	MAX63__E	-55 C to +125 C
LBO Output Current	50mA	MAX63__M	-65 C to +160 C
Power Dissipation		Storage Temperature	+300 C
Plastic DIP (derate 8.33mW/ C above +50 C)	625mW	Lead Temperature (Soldering, 10 sec.)	
Small Outline (derate 6mW/ C above +50 C)	450mW		
CERDIP (derate 8mW/ C above +50 C)	800mW		

Stresses beyond those listed under "Absolute Maximum Ratings" may cause permanent damage to the device. These are stress ratings only and functional operation of the device at these or any other conditions beyond those indicated in the operational sections of the specifications is not implied. Exposure to absolute maximum rating conditions for extended periods may affect device reliability.

ELECTRICAL CHARACTERISTICS

(TA = +25 C, unless otherwise noted.)

PARAMETER	SYMBOL	CONDITIONS	MIN	TYP	MAX	UNITS
Supply Voltage (Note 1)	+Vs	TA = +25 C Over Temperature	2.3 2.6		16.5 16.5	V
Supply Current	Is	No Load, LX Off, Over Temperature +Vs = +5V +Vs = +15V		80 260	150 500	μA
Reference Voltage	VREF	TA = +25 C Over Temperature	1.24 1.20	1.31	1.38 1.42	V
VOUT Voltage (Note 2)		MAX635A } MAX636A } MAX637A } 5% Output Accuracy	-4.75 -11.4 -14.25	-5.0 -12.0 -15.0	-5.25 -12.6 -15.75	V
		MAX635B } MAX636B } MAX637B } 10% Output Accuracy	-4.5 -10.8 -13.5	-5.0 -12.0 -15.0	-5.5 -13.2 -16.5	
Efficiency				85		%
Line Regulation (Note 2)		+5V < +Vs < +15V		0.5		%VOU1
Load Regulation (Note 2)		POUT = 0mW to 150mW		0.2		%VOU2
Oscillator Frequency	fO	+Vs = +5V MAX63_A MAX63_B	45 40	50 50	56 65	kHz
Oscillator Duty Cycle		+Vs = +5V	40	50	60	%
LX On Resistance	RON	Ix = 100mA, +Vs = +5V = +15V		9 4	16 8	Ω
LX Leakage Current	Ixl	+Vs = +16.5V TA = +25 C Over Temperature		0.01	1.0 30	μA
VFB Input Bias Current	IiB			0.01	10	nA
Low Battery Threshold	VLBI			1.31		V
Low Battery Input Bias Current	ILBI			0.01	10	nA
Low Battery Output Current	ILBO	V2 = +0.4V, V3 = +1.1V TA = 25 C Over Temperature	0.5	1.0		mA
Low Battery Output Leakage Current	ILBOI	V2 = +16.5V, V3 = +1.4V		0.01	3.0	μA

Note 1: In addition to the Absolute Maximum Rating of +18V, the input voltage also must not exceed 24V - | -VOUT |.

Note 2: Guaranteed by correlation with DC pulse measurements.

Preset/Adjustable Output CMOS Inverting Switching Regulators

Pin Description

PIN	NAME	FUNCTION	PIN	NAME	FUNCTION
1	-VOUT	The sense INPUT for fixed output operation. -VOUT, is internally connected to the on-chip voltage divider. Although it is connected to the output of the DC-DC converter (Figure 2), VOUT does not supply current. LX does.	5	LX	This pin drives the external inductor with an internal P-channel power MOSFET. LX has an output resistance of typically 6Ω and a peak current rating of 525mA.
2	LBO	Low Battery Detector Output. An open drain N-channel MOSFET which sinks current when the voltage at LBI is below 1.31V.	6	+VS	The positive Supply Voltage, from +2 to +16.5V. The total difference between the negative output voltage and the positive input must be less than 24V.
3	LBI	Low Battery Detector input. When the voltage at LBI is lower than the low Battery Detector threshold (+1.31V), LBO sinks current.	7	VREF	The Voltage Reference output is +1.31V, generated by an on-chip bandgap reference.
4	GND	Ground	8	VFB	When VFB is tied to VREF, the DC-DC converter output will be the factory preset value. When an external voltage divider is connected to VFB and VREF, this pin becomes the feedback input for adjustable output operation.

MAX635/636/637

Typical Operating Characteristics

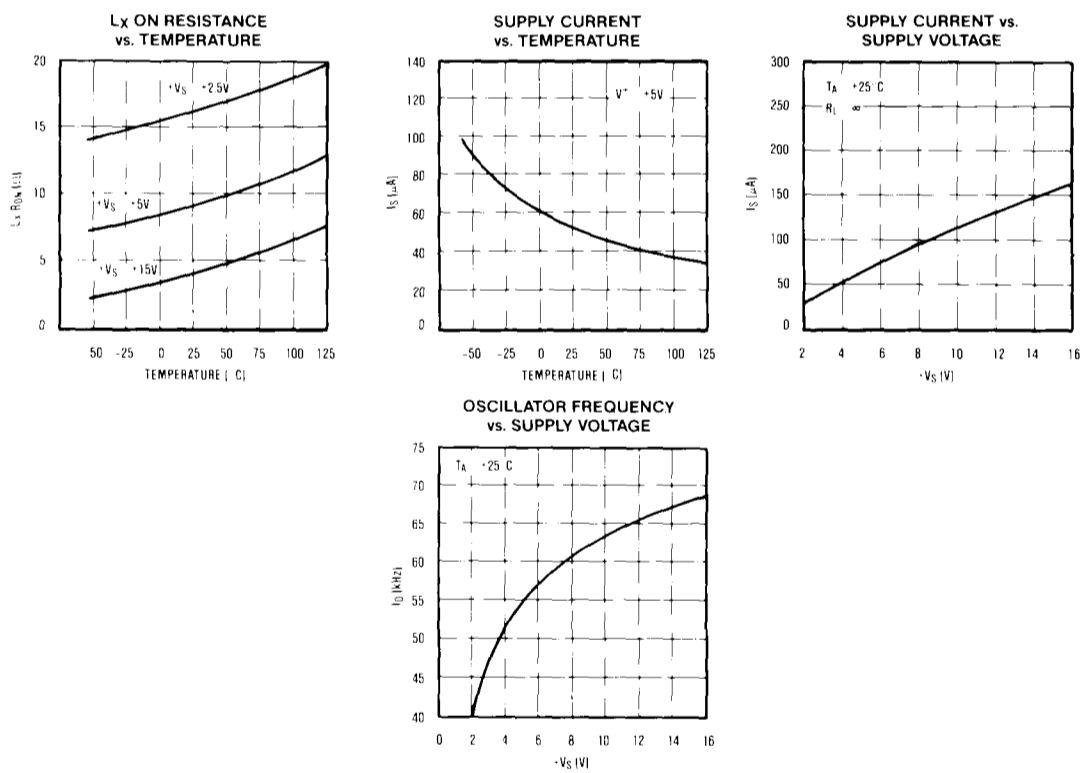

Preset/Adjustable Output CMOS Inverting Switching Regulators

Detailed Description

Principle of Operation

Figure 1 shows a simplified inverting converter. When the switch is closed, a charging current flows through the inductor, creating a magnetic field. When the switch opens, the current continues to flow through the inductor in the same direction as the charging current. Since the switch is now open, the current must flow through the diode, thereby charging the capacitor with a negative voltage. As the energy stored in the inductor is transferred to the output filter capacitor, the current linearly decays to zero, and the magnetic field collapses.

The MAX635/636/637 controls the magnitude of the negative output voltage by turning the switch on and off only when the output voltage has become more positive than the desired value.

Basic Circuit Operation

Figure 2 shows the standard circuit for converting a positive voltage into a negative one. When the output becomes more positive than the preset level, the Error Comparator switches low, and the MOSFET at LX is toggled on and off at the clock frequency. During the low-going period of the oscillator, P1 is on, and current is delivered to the external inductor through the LX pin.

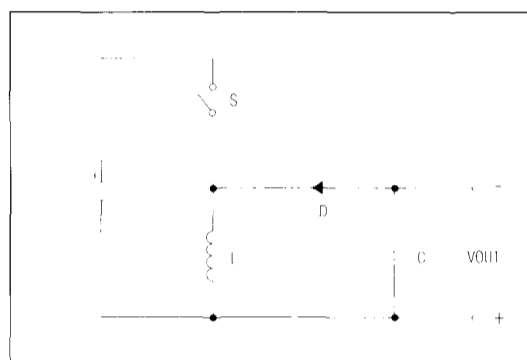

Figure 1. Simplified Inverting Converter

When the oscillator output goes high, the MOSFET turns off, but current continues to flow through the inductor. Diode D1 thus conducts, and the output filter capacitor, C1, is charged negatively.

Basic Step-Down Circuit

Table 1 lists some coil manufacturers and typical part numbers. Table 2 shows nominal inductor parameters for a variety of input and output voltages. The data refers to the circuit of Figure 2. When noise is not critical, a

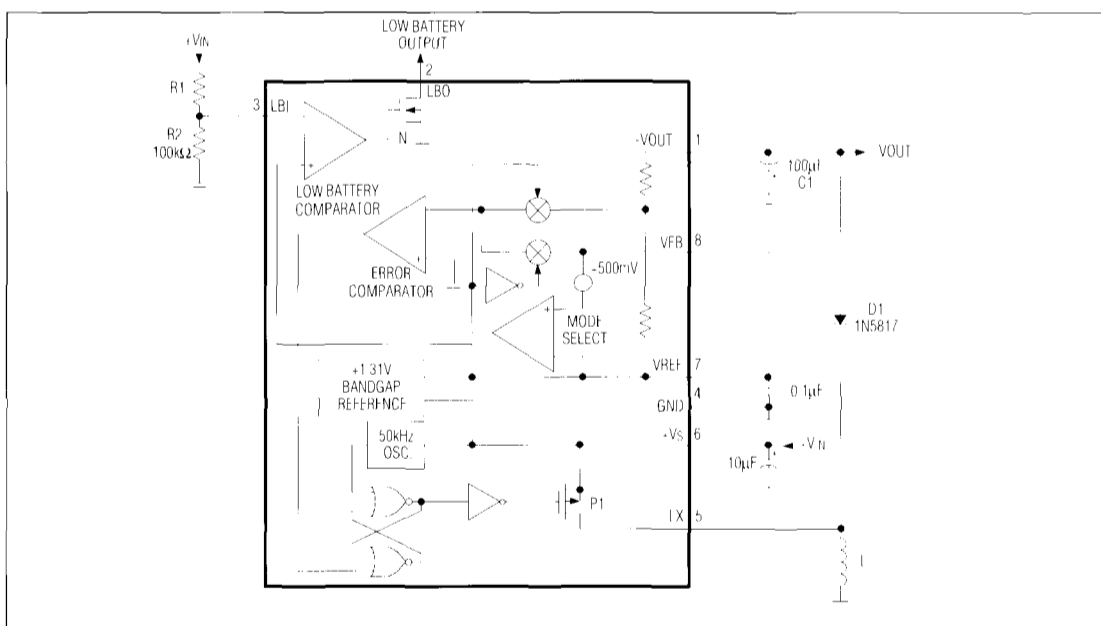

Figure 2. MAX635/636/637 Block Diagram and Typical Circuit (Table 2)

Preset/Adjustable Output CMOS Inverting Switching Regulators

low-cost bobbin inductor will suffice. For higher power circuits, or when low noise and EMI are required, pot cores or toroids should be used. If more output power is desired, see the Medium Power Inverters section.

Table 1. Coil and Core Manufacturers (Note 3)

MANUFACTURER	TYPICAL PART #	DESCRIPTION
ASIA		
TDK Corporation 13-1, Nihonbashi 1-chome Chuo-ku Tokyo 103 Japan		
EUROPE		
Richard Jahre GmbH Luetzowstrasse 90 1000 Berlin 30 Germany		
BOBBIN INDUCTORS		
Dale	IHA-104	500µH, 0.5Ω
Caddell-Burns	7070-29	220µH, 0.55Ω
Gowanda	1B253	250µH, 0.44Ω
TRW	LL-500	500µH, 0.75Ω
POTTED TOROIDAL INDUCTORS		
Dale	TE-3Q4TA	1mH, 0.82Ω
TRW	MH-1	600µH, 1.9Ω
Gowanda	050AT1003	100µH, 0.05Ω
FERRITE CORES AND TOROIDS (Note 4)		
Allen Bradley	T0451S100A	Tor. Core, 500nH/T ²
Siemens	B64290-K38-X38	Tor. Core, 4µH/T ²
Magnetics	555-130	Tor. Core, 53nH/T ²
Stackpole	57-3215	Pot Core, 14mm x 8mm
Magnetics	G-41408-25	Pot Core, 14 x 8, 250nH/T ²

Note 3: This list does not constitute an endorsement by Maxim Integrated Products and is not intended to be a comprehensive list of all manufacturers of these components.
Note 4: Permag Corp. is a distributor for many of the listed core and toroid manufacturers (516) 822-3311.

Table 2. Inductor Selection for Common Designs (Figure 2)

VIN (V)	VOUT (V)	IOUT (mA)	Part No.	INDUCTOR	
				µH	Ω
+3	-5	5	7070-27	150µH	0.43
+5	-5	25	7070-27	150µH	0.43
+9	-5	40	7070-31	330µH	0.72
+12	-5	45	7070-33	470µH	0.88
+15	-5	50	7070-35	680µH	1.5
+5	-12	12	7070-26	120µH	0.32
+9	-12	30	7070-31	330µH	0.72
+12	-12	40	7070-33	470µH	0.88
+3	-15	2	7070-27	150µH	0.43
+5	-15	8	7070-27	150µH	0.43
+9	-15	25	7070-31	330µH	0.72

Note 5: Caddell-Burns N.Y. (516) 746-2310.

Low Battery Detector

The Low Battery Output, LBO, sinks current whenever the input voltage at Low Battery Input, LBI, is less than +1.31V. LBI is a high impedance CMOS input, with less than 10nA leakage current. LBO is an open drain N-channel MOSFET with about 500Ω of output resistance. The trip voltage of the Low Battery Detector can be adjusted using an external voltage divider as shown in Figure 2. If hysteresis is desired, add a resistor between LBO and LBI.

Let R2 be any resistance in the 10kΩ to 10MΩ range, typically 100kΩ, then:

$$R1 = R2 \left(\frac{V_{LB}}{1.31V} - 1 \right)$$

(V_{LB} is the desired Low Battery detection voltage.)

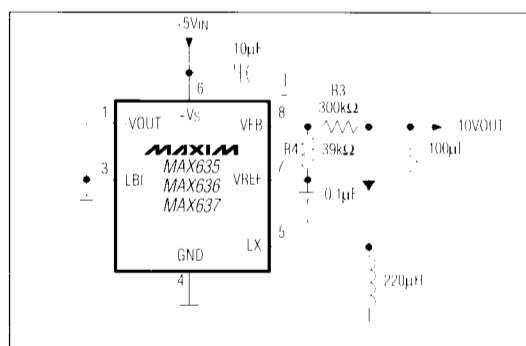

Figure 3 Adjustable Output Operation

MAX635/636/637

Preset/Adjustable Output CMOS Inverting Switching Regulators

Fixed or Adjustable Output

For operation at one of the preset output voltages (-5V for the MAX635, -12V for the MAX636, and -15V for the MAX637), VFB is connected to VREF, and no external resistors are required.

Other output voltages are selected by connecting an external voltage divider to VFB as shown in Figure 3. The output is set by R3 and R4 as follows:

Let R4 be any resistance in the 10kΩ to 10MΩ range, typically 100kΩ, then:

$$V_{OUT} = -1.31V \times \frac{R3}{R4}$$

External Components

What Value of Inductor?

A General Discussion

The converters in this data sheet operate by charging an inductor from a DC input and then discharging the inductor to generate a DC output that is opposite in polarity to the input.

Inductor selection for any DC-DC converter depends on three things: the desired output power, the input voltage (or input voltage range), and the converter's oscillator frequency and duty cycle. The oscillator timing is important because it determines how long the coil will be charged during each cycle. This, along with the input voltage, determines how much energy will be stored in the coil.

The maximum amount of energy (EL) in the coil each cycle is a function of the peak current (Ipk) and the inductance of the coil (L):

The inductor must meet four electrical criteria:

[] **Value** – low enough inductance so it stores adequate energy at the worst-case, low input voltage.

High enough so excessive and potentially destructive currents are avoided under worst-case high conditions for power-switch transistor on time and high input voltage.

[] **Saturation** – The coil must deliver the correct inductance value at the worst-case, high peak operating current.

[] **EMI** – Electromagnetic interference must not upset nearby circuitry or the regulator IC. Ferrite bobbin types work well for digital circuits; toroid or pot core types work well for EMI-sensitive analog circuits.

[] **DC resistance** – Winding resistance must be adequately low so efficiency is not affected and self-heating

does not occur. Values less than 0.5Ω are usually more than adequate.

Other inductor parameters, such as core loss or self-resonant frequency, are not a factor at the relatively low MAX635/636/637 operating frequency.

Inductor Value – Low Enough?

The problem that bites designs most often, especially in the production or pre-production phase, happens when the inductor value is too high. These units fail to deliver enough load current and exhibit poor load regulation. The worst case is:

- [] Maximum load current
- [] Minimum supply voltage
- [] Maximum inductor value, including tolerance
- [] Maximum on resistance of the switch because it reduces the excitation voltage across the inductor
- [] Worst-case low on time

Inductor Value – High Enough?

The inductor value must also be high enough so peak currents do not stress the transistor or cause the inductor core to saturate. Odd symptoms can be traced to excessive inductor currents: low efficiency, rattling heat sinks, whining coils, and increased output ripple. Very low inductor values can result in damaged power transistors.

The slope of the inductor current, and therefore the peak value that it reaches in a given on time, is determined by the supply voltage and the inductor value. The worst case occurs at:

- [] Maximum supply voltage
- [] Minimum inductor value, including tolerance
- [] Minimum on resistance of the switch
- [] Low switching frequency (or maximum switch on time)

Inductor Selection

The inductor equations below must be calculated for both worst-case sets of conditions. The final value chosen should be between the minimum value and maximum value calculated. Within these bounds, the value can be adjusted slightly lower for extra load capability or higher for lowest ripple.

$$[1] \quad I_{pk} = \frac{V_{OUT} + V_{DIODE}}{(0.25)(V_{IN} - V_{SW})} (I_{OUT})$$

$$[2] \quad L = \frac{V_{IN} - V_{SW}}{I_{pk}} (t_{ON})$$

where VSW is the voltage drop across the switch in the on state. Conservatively, the worst case is about 0.75V

Preset/Adjustable Output CMOS Inverting Switching Regulators

MAX635/636/637

max, 0.25V min with VIN = +15V and 1.5V max, 0.5V min with VIN = +5V.

Example: A +5V 10% input must be converted to -12V at 12mA.
A Schottky diode (1N5817) and a MAX636A are used.

Calculate the maximum inductor value allowed:

$$I_{pk} = \frac{12V - 0.4V}{(0.25)(4.5V - 1.5V)} (12mA) = 198mA$$

$$L = \frac{4.5V - 1.5V}{198mA} (9\mu s) = 136\mu H$$

Calculate the minimum inductor value allowed:

$$I_{pk} = 525mA \text{ (from table of max ratings; use the power MOSFET max ratings for external transistor circuits.)}$$

$$L = \frac{5.5V - 0.5V}{525mA} (11\mu s) = 105\mu H$$

A value of 120μH would be a good choice for this application.

I_{pk} must also be compared to the current rating of the LX switch. If I_{pk} exceeds the peak current rating of the switch (525mA), an external MOSFET or transistor with an adequate current rating must be used (see Medium Power Inverters).

The coil resistance has a significant effect on the output current; a coil with a low resistance will increase the output current and overall efficiency. The inductor

should have a powdered iron or ferrite core and should have a resistance less than 0.5Ω.

Medium Power Inverters

In the circuit of Figure 4, the MAX626 MOSFET driver is used to convert the open drain LX output to a signal suitable for driving the gate of an external P-Channel MOSFET. The IRF9541 has a gate threshold voltage of 2V to 4V so it will have a relatively high resistance if driven with only 5V of gate drive. To increase the gate drive voltage, and thereby increase efficiency, the negative supply pin of the CMOS inverter is connected to the negative output rather than to the ground. Once the circuit is started, the gate drive swings from +5V to -VOUT.

At start-up, the voltage at -VOUT is one Schottky diode drop above ground, and the gate drive to the power MOSFET is slightly less than 5V. The output should be only lightly loaded to ensure start-up, since the output power capability of the circuit is very low until -VOUT is a couple of volts negative. (See Table 3 for component values for L2 and IC1.)

Table 3. Component Selection - Medium Power Inverters (Figure 4)

V _{IN}	-V _{OUT}	I _{OUT}	EFFICIENCY	IC1	L1
5V	-5V	400mA	70%	MAX635	27μH
5V	-5V	500mA	64%	MAX635	18μH
5V	-12V	150mA	75%	MAX636	27μH
5V	-12V	200mA	70%	MAX636	18μH

Notes: 18μH Coil = Caddell-Burn's (Mineola, NY) Model 6860-04.
27μH Coil = Caddell-Burn's Model 6860-06.

External Diode

In most DC-DC converter circuits, the current in the "catch" diode (Figure 2, D1) abruptly goes from zero to its peak value each time the MOSFET at LX switches off. To avoid excessive losses, the diode must have a fast turn-on time. For low power circuits with peak currents less than 100mA, signal diodes such as 1N4148s perform well. For higher current circuits, or for maximum efficiency at low power, the 1N5817 series of Schottky diodes are recommended. Although 1N4001s and other general purpose rectifiers are rated for high currents, they are unacceptable because their slow turn-on time results in excessive losses.

Output Filter Capacitor

The MAX635/636/637's output ripple has 2 components which are 90° out of phase. One component results from the change in the stored charge on the filter capacitor with each LX pulse. The other is the product of the capacitor's charge-discharge current and its Equivalent

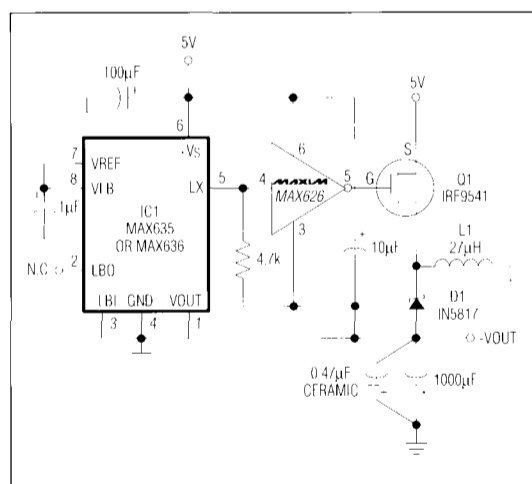

Figure 4. Medium Power Inverter

Preset/Adjustable Output CMOS Inverting Switching Regulators

Series Resistance (ESR). With low-cost aluminum electrolytic capacitors, the ESR produced ripple is often larger than that caused by the change in charge. Consequently, high quality aluminum or tantalum filter capacitors will minimize output ripple, even if smaller capacitance values are used. Best results at reasonable cost are typically achieved with a high quality aluminum electrolytic, in the 100 μ F to 500 μ F range, in parallel with a 0.1 μ F ceramic capacitor.

Application Hints

Inductor Saturation

When using off-the-shelf inductors, make sure that their peak current rating is observed. When designing your own inductors, observe the core manufacturer's Ampere-turns or NI ratings. Failure to observe the peak current or NI ratings may lead to saturation of the inductor, especially in circuits with external boosting transistors. Inductor saturation leads to very high current levels through the power switching device causing excessive power dissipation, poor efficiency, and possible damage.

Test for saturation by applying the maximum load and the maximum input voltage while monitoring the inductor current with a current probe. The normal inductor current waveform is a sawtooth with a linear current ramp. Saturation creates a nonlinear current waveform with a very rapid increase in current once the inductor saturates.

Ordering Information (continued)

PART*	TEMP. RANGE	PIN - PACKAGE
MAX637XCPA	0°C to +70°C	8 Plastic DIP
MAX637XCSEA	0°C to +70°C	8 Narrow SO
MAX637XCJA	0°C to +70°C	8 CERDIP
MAX637XC/D	0°C to +70°C	Dice
MAX637XEPA	-40°C to +85°C	8 Plastic DIP
MAX637XESA	-40°C to +85°C	8 Narrow SO
MAX637XEJA	-40°C to +85°C	8 CERDIP
MAX637XMJA	-55°C to +125°C	8 CERDIP

*X = A for 5% Output Accuracy. X = B for 10% Output Accuracy.

Bypassing and Compensation

The high current pulses in the LX output and the external inductor can cause erratic operation unless the MAX635/636/637 is properly bypassed. Connect a 10mF bypass capacitor directly across the device between +VS and GND to minimize the inductance and high frequency impedance of the power source. Also make sure that the high current ground return path of the inductor does not cause a voltage drop in the regulator's ground line.

The reference voltage output, VREF, should be bypassed to ground with a 0.1 μ F capacitor. Avoid coupling to the high current path that includes the LX output and the inductor ground return.

When the value of the voltage setting resistors (R3 and R4, Figure 3) exceed 50k Ω , stray capacitance at the VFB input can add a "lag" to the feedback response causing output pulses to occur in bursts. This increases low-frequency ripple and lowers efficiency. This problem can often be avoided by minimizing lead lengths and circuit board trace size at the VFB node. Normal operation with evenly distributed output pulses can be restored by adding a "lead" compensation capacitor (100pF to 10nF) in parallel with R3.

Chip Topography

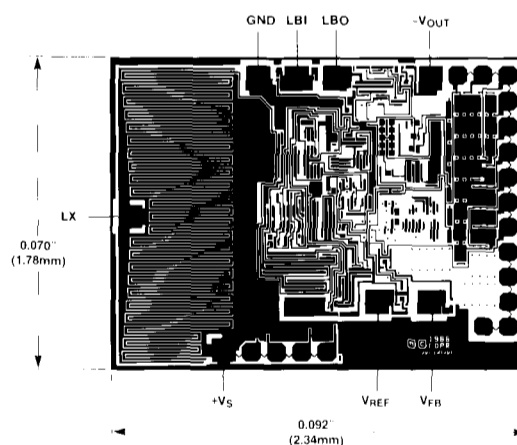

Maxim cannot assume responsibility for use of any circuitry other than circuitry entirely embodied in a Maxim product. No circuit patent licenses are implied. Maxim reserves the right to change the circuitry and specifications without notice at any time.

8 Maxim Integrated Products, 120 San Gabriel Drive, Sunnyvale, CA 94086 (408) 737-7600

©1990 Maxim Integrated Products Printed USA 3/90 MAXIM is a registered trademark of Maxim Integrated Products.