



Analog Solutions—Robust Reliable Performance

# MC33909

## System Basis Chip with DCDC and Multiple Switch-to-Ground Interface

### Overview

Within rear body controllers and gateway module applications, the growing demand of safety, robustness and system optimization is driving OEM manufacturers to enhance different implementations including MCU and power management solutions using System Basic Chips (SBC).

As an advanced power management unit, the MC33909 device works with MCUs and additional integrated circuits such as sensors, CAN transceivers and eXtreme switches. The MC33909 device has a secure SPI and advanced watchdog with selectable timing for secure SPI commands and transitions into critical SBC states, which allows for implementation of a functional safety module. Freescale's MC33909 SBC integrates common functionality of system basis chips with a low voltage operation DCDC and 6 multiple switch-detection inputs.

Notably, the MC33909 device implements an innovative and advanced fail-safe state machine solution that supports applications with ASIL B safety requirements. It does this through low-power modes with multiple wake-up capabilities and has one built-in enhanced high-speed CAN interface (ISO 11898-2 and -5) with local and bus failure diagnostics, protection and fail-safe operation modes. The MC33909 scalable part numbers offer from 0 up to 4 LIN interfaces compatible with LIN 2.1 and SAE J2602-2 specifications.

### Target Applications

- Front/rear body controllers
- Gateway modules
- HVAC
- Power Management

### Simplified Applications Drawing

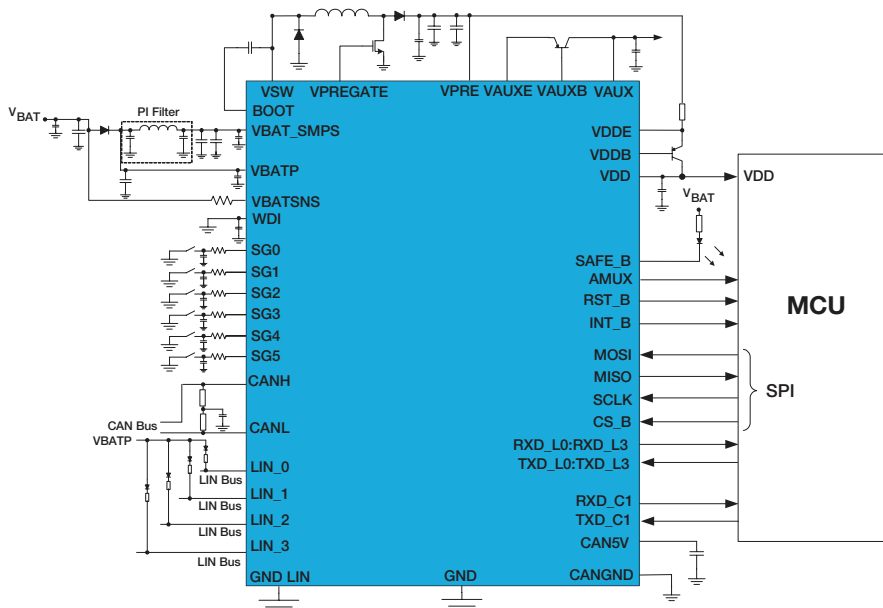

The MC33909 SBC is extremely robust with CAN and LIN support, 6 switch inputs, and low quiescent current for prolonged battery life. With the high level of integration within the MC33909 device, customers are able to generate a low cost bill of materials implementation.

## Freescale: A Leader in Analog Solutions

Expanding on more than 30 years of innovation, Freescale is a leading provider of high-performance products that use SMARTMOS technology combining digital, power and standard analog functions. Freescale supplies analog and power management ICs that are advancing the automotive, consumer, industrial and networking markets. Analog solutions interface with real-world signals to control and drive for complete embedded systems.



48 LQFP-EP  
98ASA00737D

## Product Features and Benefits

Features	Function	Benefits
$V_{DD}$ rail (3.3 or 5.0 V) operates down to 2.5 V on VBATP (provided by VPRE Buck/Boost)	+/-2% accuracy regulated output voltage to supply MCU	LV124-compliant System Basis Chip
Supports low-voltage startup at VBATP = 5.3 V and the low-voltage crank profile to VBATP = 2.5 V	Parametrically functional during low battery conditions	Can sustain crank pulse voltages and other noise transients on the battery in line with LV124
Low quiescent current operation for low-power mode	Multiple low-power modes with VDD ON and OFF with wake-up capability	Ultra-low module current consumption for prolonged battery life during key-OFF conditions. 100 $\mu$ A typical
$V_{AUX}$ rail (3.3 or 5.0 V) capable of surviving short to battery (40 V) conditions	Additional regulator to supply other ICs	Increases module flexibility and intelligence via implementation of multiple ICs supplied by SBC
Single CAN interface compatible with ISO 11898-2 and -5 specifications	CAN physical layers for module to module communication	Robust CAN protocol-compliant physical layer
From 0 up to 4 (part number selectable) LIN interfaces compatible with LIN 2.1 and SAEJ2602-2 specifications	Multiple LIN physical layers for module to module communication	Robust LIN protocol-compliant physical layer
Secured SPI and advanced watchdog	Simple window, timeout and advanced watchdog with selectable timing. Secured SPI commands for transitions into critical SBC states	Enhanced security for MCU and SBC communication, which allows the implementation of a functional safety module
SAFE_B pin for limp home mode	Active low output to enable SAFE circuitry to be isolated from the MCU and the SBC	Allows functional safety implementation of the module by known reaction to various faults
6 switch-to-GND inputs	Multiple switch inputs to GND with wake-up capability and wetting current	Robust inputs with configurable timing allow for low module current consumption and clean contacts for closed switches
Analog multiplexer	VDD referenced multiplexed output for switch to GND voltages, internal device temperature and battery voltage	Allows MCU to read critical voltages via SPI commands to deal with faults and acquire module status

## Documentation

Freescale Document Number	Title	Description
MC33909	System Basis Chip with Multiple Switch-to-Ground Interface	Data sheet
SG1002	Analog Product Selector Guide	Selector guide
SG187	Automotive Product Selector Guide	Selector guide

For more information, please visit [freescale.com/analog](http://freescale.com/analog)

Freescale and the Freescale logo are trademarks of Freescale Semiconductor, Inc., Reg. U.S. Pat. & Tm. Off. SMARTMOS is a trademark of Freescale Semiconductor, Inc. All other product or service names are the property of their respective owners. © 2013, 2015 Freescale Semiconductor, Inc.

Document Number: MC33909FS REV 2