

DUAL SENSE AMPLIFIERS

MC7520L thru MC7523L

Advance Information

MONOLITHIC DUAL SENSE AMPLIFIERS

These dual sense amplifiers are designed for high-speed core memory systems. Low-level pulses originating in the memory are converted to logic levels compatible with M TTL and MD TL circuits. Each of the two basic device functions has two different threshold specifications. The dual-input preamplifiers are connected to a common output stage, with each preamplifier output strobed independently.

The output circuit of the MC7520L/MC7521L is comprised of two cascaded NAND gates, each having an external gate input. The external gate inputs may be used to connect the \bar{Q} output to the Gate Q input to achieve a flip-flop or register that responds to the sense and strobe input conditions. Output pulse stretching may be accomplished by resistive/capacitive coupling from the \bar{Q} output to the Gate Q input.

The output circuit of the MC7522L/MC7523L features an open-collector output, permitting the wired-OR function. Load resistor R_L may be used as the output pullup resistor.

- Adjustable Threshold Voltage Levels
- High Speed, Fast Recovery Time
- Time and Amplitude Signal Discrimination
- High dc Logic Noise Margin – 1.0 Volt typical
- Good Fanout Capability

DUAL HIGH-SPEED SENSE AMPLIFIER INTEGRATED CIRCUITS MONOLITHIC SILICON EPITAXIAL PASSIVATED

CERAMIC PACKAGE
CASE 620

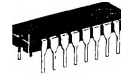

MC7520L and MC7521L

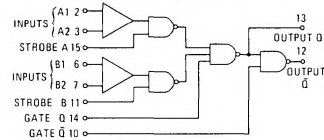

MC7522L and MC7523L

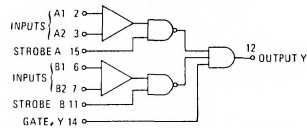

COMMON TO ALL DEVICES

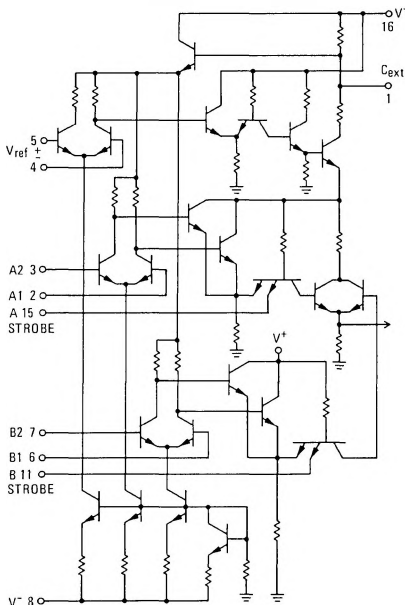

MC7520L and MC7521L ONLY

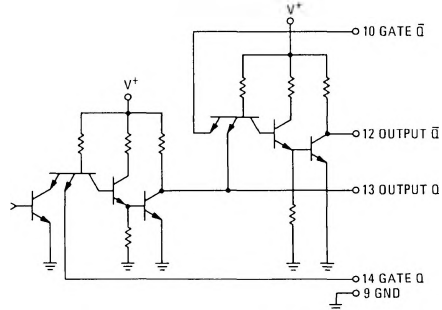

MC7522L and MC7523L ONLY

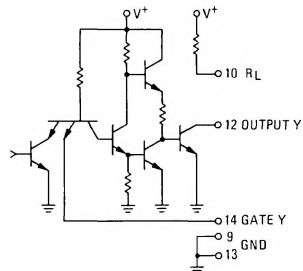

MC7520L thru MC7523L (continued)

ELECTRICAL CHARACTERISTICS ($V^+ = 5.0\text{ V}$, $V^- = -5.0\text{ V}$, $T_A = 0$ to $+70^\circ\text{C}$ unless otherwise noted)

Characteristic	Symbol	Min	Typ	Max	Unit	
Input Threshold Voltage $V_{ref} = 15\text{ mV}$	V_{th}	11	15	19	mV	
MC7520L,MC7522L MC7521L,MC7523L		8.0	15	22		
$V_{ref} = 40\text{ mV}$		36	40	44		
MC7520L,MC7522L MC7521L,MC7523L		33	40	47		
Common-Mode Input Firing Voltage	V_{CMF}	–	± 3.0	–	Volts	
Input Bias Current	I_{in}	–	30	75	μA	
Input Offset Current	I_{io}	–	0.5	–	μA	
Input Impedance ($f = 1.0\text{ kHz}$)	$Z_{(in)\ D}$	–	2.0	–	k ohms	
Input Voltage Logic "1" Level (Strobe Inputs) $V_{in}\ "0" = 0.8\text{ V}$	$V_{in}\ "1"$	2.0	–	–	Volts	
Input Voltage Logic "0" Level (Strobe Inputs) $V_{in}\ "1" = 2.0\text{ V}$	$V_{in}\ "0"$	–	–	0.8	Volt	
Input Current Logic "0" Level (Strobe Inputs) $V_{in}\ "0" = 0.4\text{ V}$	$I_{in}\ "0"$	–	–	-1.6	mA	
Input Current Logic "1" Level (Strobe Inputs) $V_{in}\ "1" = 2.4\text{ V}$	$I_{in}\ "1"$	–	–	40	μA	
		$V_{in}\ "1" = V^+$	–	–	1.0	mA
Output Voltage Logic "1" Level $V_{in}\ "1" = 2.0\text{ V}$	$V_{out}\ "1"$	2.4	3.9	–	Volts	
Output Voltage Logic "0" Level $V_{in}\ "0" = 0.8\text{ V}$	$V_{out}\ "0"$	–	0.25	0.4	Volt	
Short-Circuit Output Current Q Output MC7520L,MC7521L \bar{Q} Output MC7520L,MC7521L Output MC7522L,MC7523L	I_{SC}	3.3	–	5.0	mA	
		2.1	–	3.5		
		2.1	–	3.5		
V^+ Supply Current ($T_A = +25^\circ\text{C}$)	MC7520L,MC7521L MC7522L,MC7523L	I^+	–	28	–	mA
			–	27	–	
V^- Supply Current ($T_A = +25^\circ\text{C}$)	MC7520L,MC7521L MC7522L,MC7523L	I^-	–	-14	–	mA
			–	-15	–	

SWITCHING CHARACTERISTICS ($V^+ = 5.0\text{ V}$, $V^- = -5.0\text{ V}$, $T_A = +25^\circ\text{C}$ unless otherwise noted)

Characteristic	Symbol	Min	Typ	Max	Unit
Differential-Mode Input Overload Recovery Time	$t_{OR\ DM}$	–	20	–	ns
Common-Mode Input Overload Recovery Time	$t_{OR\ CM}$	–	20	–	ns
Minimum Cycle Time	$t_c\ (\text{min})$	–	200	–	ns

MC7520L, MC7521L

Characteristic	Symbol	Min	Typ	Max	Unit
Propagation Delay Time (Differential Input to Q Output)	$t_{pd}\ "1" DQ$	–	20	40	ns
		–	30	–	
(Differential Input to \bar{Q} Output)	$t_{pd}\ "1" D\bar{Q}$	–	25	–	
		–	35	55	
(Strobe Input to Q Output)	$t_{pd}\ "1" SQ$	–	15	30	
		–	25	–	
(Strobe Input to \bar{Q} Output)	$t_{pd}\ "1" S\bar{Q}$	–	15	–	
		–	35	55	
(Gate Q Input to Q Output)	$t_{pd}\ "1" G_QQ$	–	10	20	
		–	15	–	
(Gate Q Input to \bar{Q} Output)	$t_{pd}\ "1" G_Q\bar{Q}$	–	15	–	
		–	20	30	
(Gate \bar{Q} Input to \bar{Q} Output)	$t_{pd}\ "1" G_{\bar{Q}}\bar{Q}$	–	15	–	
		–	10	20	

MC7522L, MC7523L

Characteristic	Symbol	Min	Typ	Max	Unit
Propagation Delay Time (Differential Input to Output)	$t_{pd}\ "1" D$	–	20	–	ns
		–	30	45	
(Strobe Input to Output)	$t_{pd}\ "1" S$	–	15	–	
		–	25	40	
(Gate Input to Output)	$t_{pd}\ "1" G$	–	10	–	
		–	15	25	

MC7520L thru MC7523L (continued)

MAXIMUM RATINGS ($T_A = +25^\circ\text{C}$ unless otherwise noted)

Rating	Symbol	Value	Units
Power Supply Voltage	V^+	+7.0	Vdc
	V^-	-7.0	Vdc
Differential Input Signal Voltage	V_{in}	± 5.0	Vdc
Strobe and Gate Input Voltage	$V_{inS,G}$	± 5.5	Vdc
Power Dissipation Derate above $T_A = +25^\circ\text{C}$	P_D	575	mW
		3.85	mW°C
Operating Temperature Range	T_A	0 to +70	$^\circ\text{C}$
Storage Temperature Range	T_{stg}	-65 to +150	$^\circ\text{C}$