

MCC1711 MCC1711C

DIFFERENTIAL COMPARATORS

Advance Information

MONOLITHIC DUAL DIFFERENTIAL VOLTAGE COMPARATOR CHIP

... designed for use in level detection, low-level sensing, and memory applications.

The MCC1711 and MCC1711C employ phosphorsilicate passivation that protects the entire die surface area, including metalization interconnects. All dice have a minimum gold-backed thickness of 4000 Angstroms. The interconnecting metalization and bonding pads are of evaporated aluminum.

- Differential Input –
Input Offset Voltage = 1.0 mV
Offset Voltage Drift = 5.0 $\mu\text{V}/^\circ\text{C}$
- Fast Response Time – 40 ns
- Output Compatible with All Saturating Logic Forms –
 $V_{\text{out}} = +4.5 \text{ V to } -0.5 \text{ V Typical}$
- Low Output Impedance – 200 Ohms

DUAL DIFFERENTIAL
COMPARATOR CHIP
INTEGRATED CIRCUIT

MONOLITHIC SILICON
EPITAXIAL PASSIVATED

OUTLINE DIMENSIONS and BONDING DIAGRAM

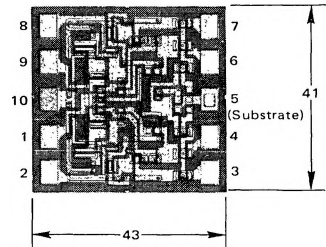

All dimensions are nominal and in mils (10^{-3} inches).
Die Dimensions
Thickness = 8.0
Bonding Pads = 4.0 x 4.0

MAXIMUM RATINGS ($T_A = 25^\circ\text{C}$ unless otherwise noted)

Rating	Symbol	Value	Unit
Power Supply Voltage	V^+	+14	Vdc
	V^-	-7.0	Vdc
Differential Input Signal	V_{in}	± 5.0	Volts
Common Mode Input Swing	CMV_{in}	± 7.0	Volts
Peak Load Current	I_L	50	mA
Operating Temperature Range	T_A	-55 to +125	$^\circ\text{C}$
Junction Temperature Range	T_J	-65 to +150	$^\circ\text{C}$

CIRCUIT SCHEMATIC

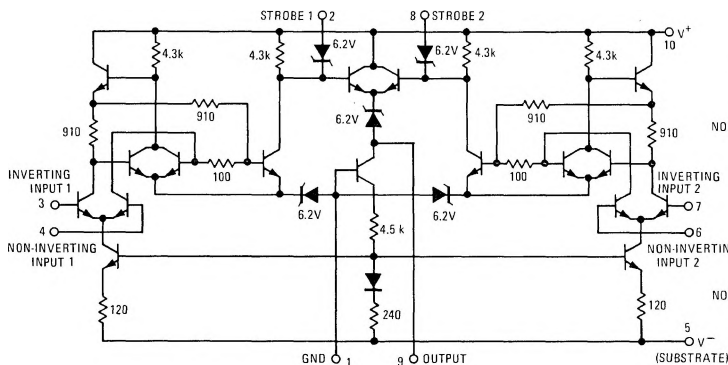

EQUIVALENT CIRCUIT

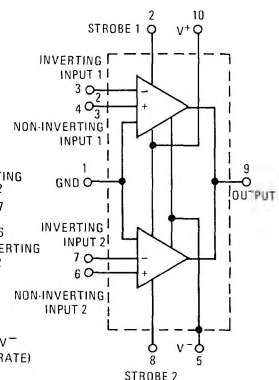

MCC1711, MCC1711C (continued)

ELECTRICAL CHARACTERISTICS (each comparator) ($V^+ = +12$ Vdc, $V^- = -6.0$ Vdc, $T_A = 25^\circ\text{C}$ unless otherwise noted)

Characteristic	Symbol	MCC1711			MCC1711C			Unit
		Min	Typ	Max	Min	Typ	Max	
Input Offset Voltage ($V_O = 1.4$ Vdc)	V_{IO}	-	1.0	3.5	-	1.0	5.0	mVdc
Input Bias Current ($V_O = 1.4$ Vdc)	I_B	-	25	75	-	25	100	μAdc
Output Resistance	R_{Out}	-	200	-	-	200	-	Ohms
Positive Output Voltage ($V_{in} \geq 10$ mVdc, $0 \leq I_O \leq 5.0$ mA)	V_{OH}	2.5	3.2	5.0	2.5	3.2	5.0	Vdc
Negative Output Voltage ($V_{in} \leq -10$ mVdc)	V_{OL}	-1.0	-0.5	0	-1.0	-0.5	0	Vdc
Strobed Output Level ($V_{strobe} \leq 0.3$ Vdc)	$V_{OL(st)}$	-1.0	-	0	-1.0	-	0	Vdc
Output Sink Current ($V_{in} \geq -10$ mV, $V_O \geq 0$)	I_S	0.5	0.8	-	0.5	0.8	-	mAdc
Strobe Current ($V_{strobe} = 100$ mVdc)	I_{st}	-	1.2	2.5	-	1.2	2.5	mAdc
Response Time ($V_b = 5.0$ mV + V_{IO})	t_R	-	40	-	-	40	-	ns
Strobe Release Time	t_{SR}	-	12	-	-	12	-	ns
Power Supply Current ($V_O \leq 0$ Vdc)	I_{D^+} I_{D^-}	-	8.6 3.9	-	-	8.6 3.9	-	mAdc
Power Consumption		-	130	200	-	130	200	mW

See current MCC1711/1711C data sheet for additional information.

PACKAGING AND HANDLING

The MCC1711/MCC1711C dual differential comparator is now available as a single monolithic die or encapsulated in the TO-91, TO-100, and TO-116 hermetic packages. The phosphorsilicate passivation protects the metalization and active area of the die but care must be exercised when removing the dice from the shipping carrier to avoid scratching the bonding pads. A vacuum pickup is useful for handling of dice. Tweezers are not recommended for this purpose.

The non-spill type shipping carrier consists of a compartmentalized tray and fitted cover. Die are placed in the carrier with geometry side up.