

MDC3205

Advance Information

Integrated Relay/Solenoid Driver

- Optimized to Switch 3 V to 5 V Relays from a 5 V Rail
- Compatible with “TX” and “TQ” Series Telecom Relays Rated up to 625 mW at 3 V to 5 V
- Features Low Input Drive Current
- Internal Zener Clamp Routes Induced Current to Ground Rather Than Back to Supply
- Guaranteed Off State with No Input Connection
- Supports Large Systems with Minimal Off-State Leakage
- ESD Resistant in Accordance with the 2000 V Human Body Model
- Provides a Robust Driver Interface Between Relay Coil and Sensitive Logic Circuits

Applications include:

- Telecom Line Cards and Telephony
- Industrial Controls
- Security Systems
- Appliances and White Goods
- Automated Test Equipment
- Automotive Controls

This device is intended to replace an array of three to six discrete components with an integrated part. It can be used to switch other 3 to 5 Vdc Inductive Loads such as solenoids and small DC motors.

MAXIMUM RATINGS

Rating	Symbol	Value	Unit
Power Supply Voltage	V_{CC}	6.0	Vdc
Recommended Operating Supply Voltage	V_{CC}	2.0–5.5	Vdc
Input Voltage	$V_{in(fwd)}$	6.0	Vdc
Reverse Input Voltage	$V_{in(rev)}$	–0.5	Vdc
Output Sink Current — Continuous	I_O	300	mA
Junction Temperature	T_J	150	°C
Operating Ambient Temperature Range	T_A	–40 to +85	°C
Storage Temperature Range	T_{stg}	–65 to +150	°C

THERMAL CHARACTERISTICS

Characteristic	Symbol	Max	Unit
Total Device Dissipation ⁽¹⁾ Derate above 25°C	P_D	625	mW
Thermal Resistance Junction to Ambient	$R_{\theta JA}$	200	°C/W

1. FR-5 PCB of 1" x 0.75" x 0.062", $T_A = 25^\circ\text{C}$

This document contains information on a new product. Specifications and information herein are subject to change without notice.

RELAY/SOLENOID DRIVER SILICON MONOLITHIC CIRCUIT BLOCK



CASE 29–11, STYLE 14
TO–92

INTERNAL CIRCUIT DIAGRAM

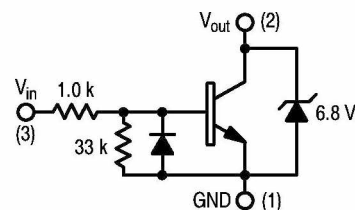

MDC3205

ELECTRICAL CHARACTERISTICS ($T_A = 25^\circ\text{C}$ unless otherwise noted)

Characteristic	Symbol	Min	Typ	Max	Unit
OFF CHARACTERISTICS					
Output Zener Breakdown Voltage (@ $I_T = 10\text{ mA}$ Pulse)	$V_{(BRout)}$ $V_{(-BRout)}$	6.4 —	6.8 -0.7	7.2 —	V
Output Leakage Current @ 0 Input Voltage ($V_{out} = 5.5\text{ Vdc}$, $V_{in} = \text{O.C.}$, $T_A = 25^\circ\text{C}$) ($V_{out} = 5.5\text{ Vdc}$, $V_{in} = \text{O.C.}$, $T_A = 85^\circ\text{C}$)	I_{OO}	— —	— —	5.0 30	μA
ON CHARACTERISTICS					
Input Bias Current @ $V_{in} = 4.0\text{ Vdc}$ ($I_O = 250\text{ mA}$, $V_{out} = 0.4\text{ Vdc}$, $T_A = -40^\circ\text{C}$) (correlated to a measurement @ 25°C)	I_{in}	—	2.5	—	mAdc
Output Saturation Voltage ($I_O = 250\text{ mA}$, $V_{in} = 4.0\text{ Vdc}$, $T_A = -40^\circ\text{C}$) (correlated to a measurement @ 25°C)		—	0.2	0.4	Vdc
Output Sink Current — Continuous ($T_A = -40^\circ\text{C}$, $V_{CE} = 0.4\text{ Vdc}$, $V_{in} = 4.0\text{ Vdc}$) (correlated to a measurement @ 25°C)	$I_{C(on)}$	250	—	—	mA

TYPICAL APPLICATION-DEPENDENT SWITCHING PERFORMANCE

SWITCHING CHARACTERISTICS

Characteristic	Symbol	V_{CC}	Min	Typ	Max	Units
Propagation Delay Times:						ns
High to Low Propagation Delay; Figures 1, 2 (5.0 V 74HC04)	t_{PHL}	5.5	—	55	—	
Low to High Propagation Delay; Figures 1, 2 (5.0 V 74HC04)	t_{PLH}	5.5	—	430	—	
High to Low Propagation Delay; Figures 1, 3 (3.0 V 74HC04)	t_{PHL}	5.5	—	85	—	
Low to High Propagation Delay; Figures 1, 3 (3.0 V 74HC04)	t_{PLH}	5.5	—	315	—	
High to Low Propagation Delay; Figures 1, 4 (5.0 V 74LS04)	t_{PHL}	5.5	—	55	—	
Low to High Propagation Delay; Figures 1, 4 (5.0 V 74LS04)	t_{PLH}	5.5	—	2385	—	
Transition Times:						ns
Fall Time; Figures 1, 2 (5.0 V 74HC04)	t_f	5.5	—	45	—	
Rise Time; Figures 1, 2 (5.0 V 74HC04)	t_r	5.5	—	160	—	
Fall Time; Figures 1, 3 (3.0 V 74HC04)	t_f	5.5	—	70	—	
Rise Time; Figures 1, 3 (3.0 V 74HC04)	t_r	5.5	—	195	—	
Fall Time; Figures 1, 4 (5.0 V 74LS04)	t_f	5.5	—	45	—	
Rise Time; Figures 1, 4 (5.0 V 74LS04)	t_r	5.5	—	2400	—	
Input Slew Rate ⁽¹⁾	$\Delta V/\Delta t_{in}$	5.5	TBD	—	—	V/ms

1. Minimum input slew rate must be followed to avoid overdissipating the device.

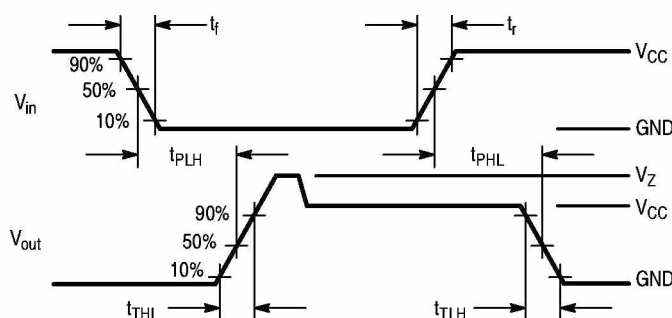

Figure 1. Switching Waveforms

MDC3205

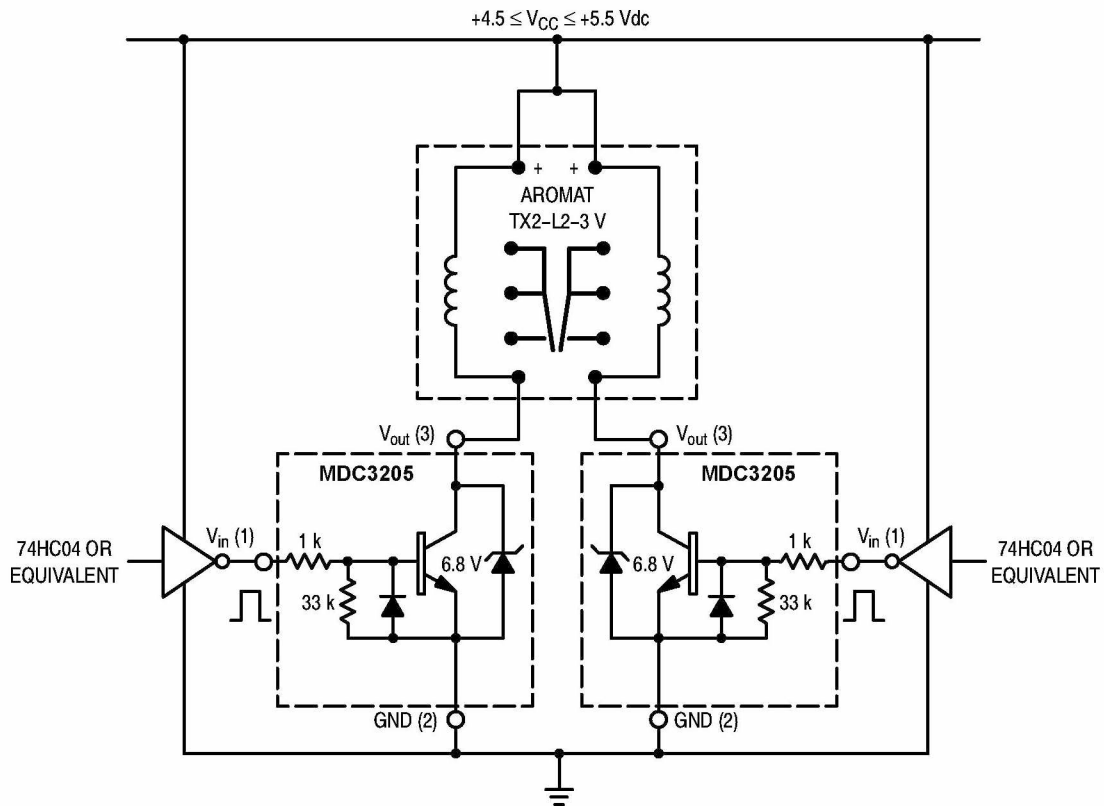

Figure 2. A 3.0-V, 200-mW Dual Coil Latching Relay Application with 5.0 V-HCMOS Interface

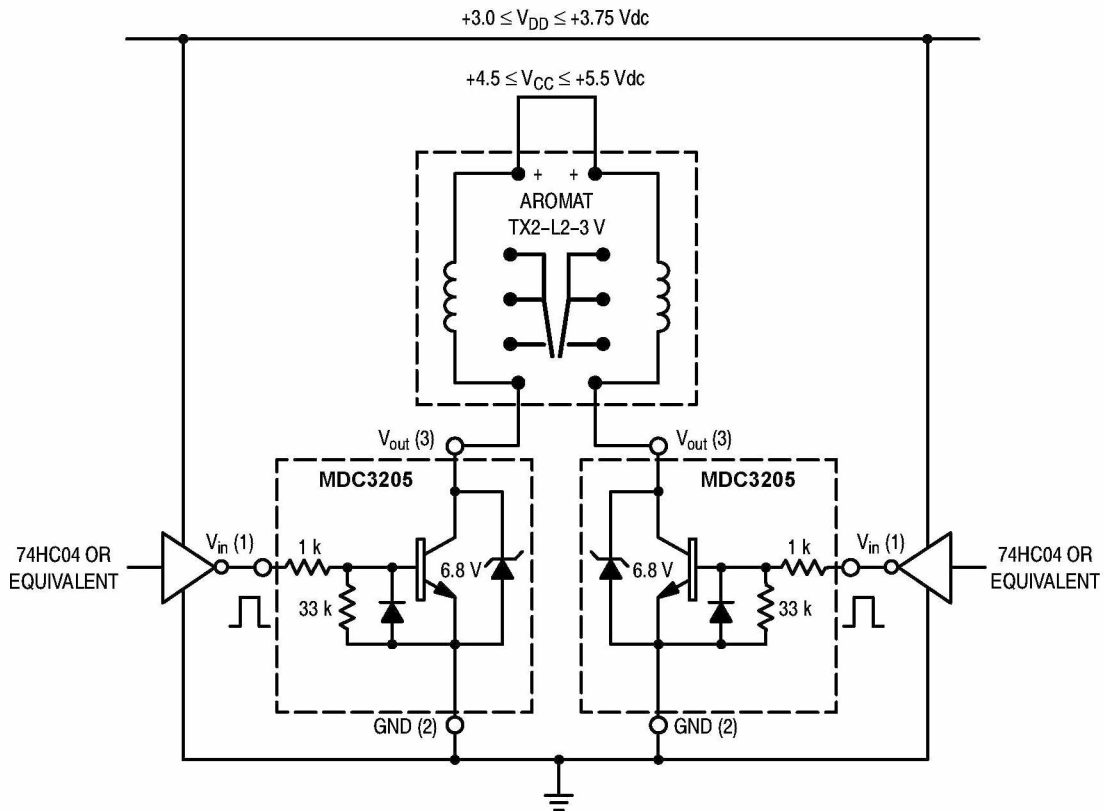

Figure 3. A 3.0-V, 200-mW Dual Coil Latching Relay Application with 3.0 V-HCMOS Interface

MDC3205

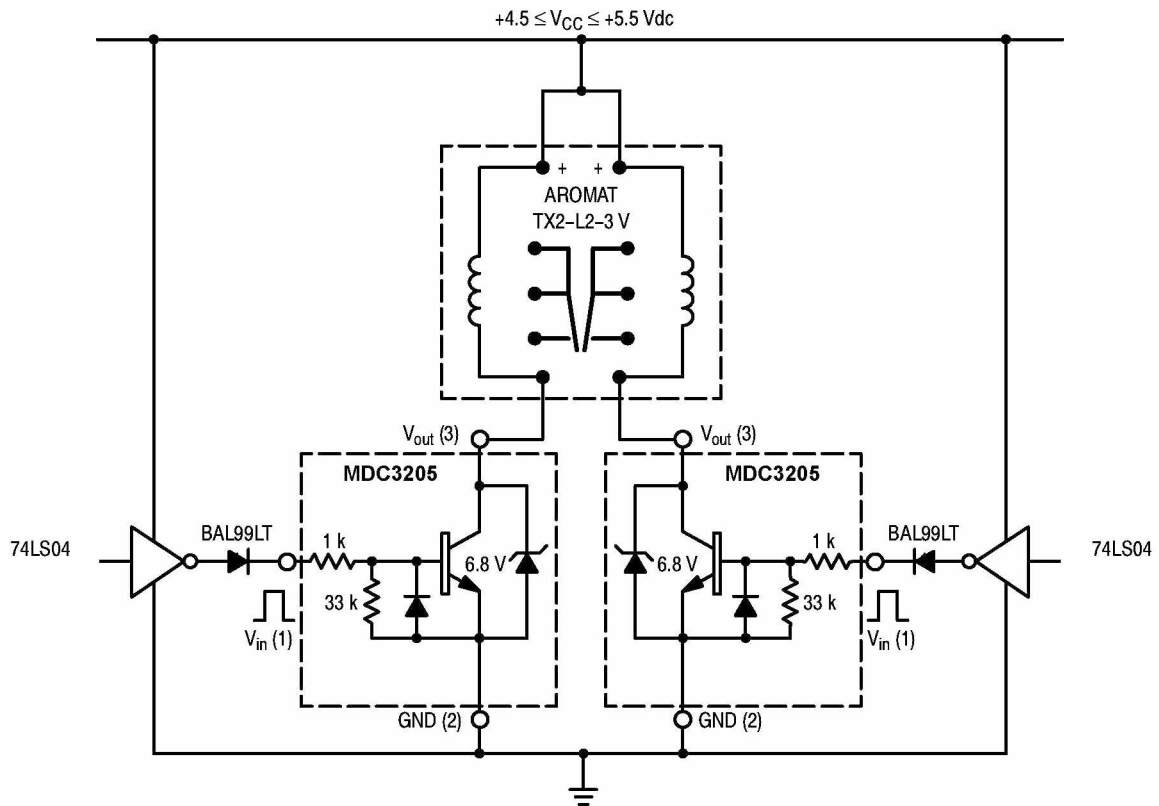

Figure 4. A 3.0-V, 200-mW Dual Coil Latching Relay Application with TTL Interface

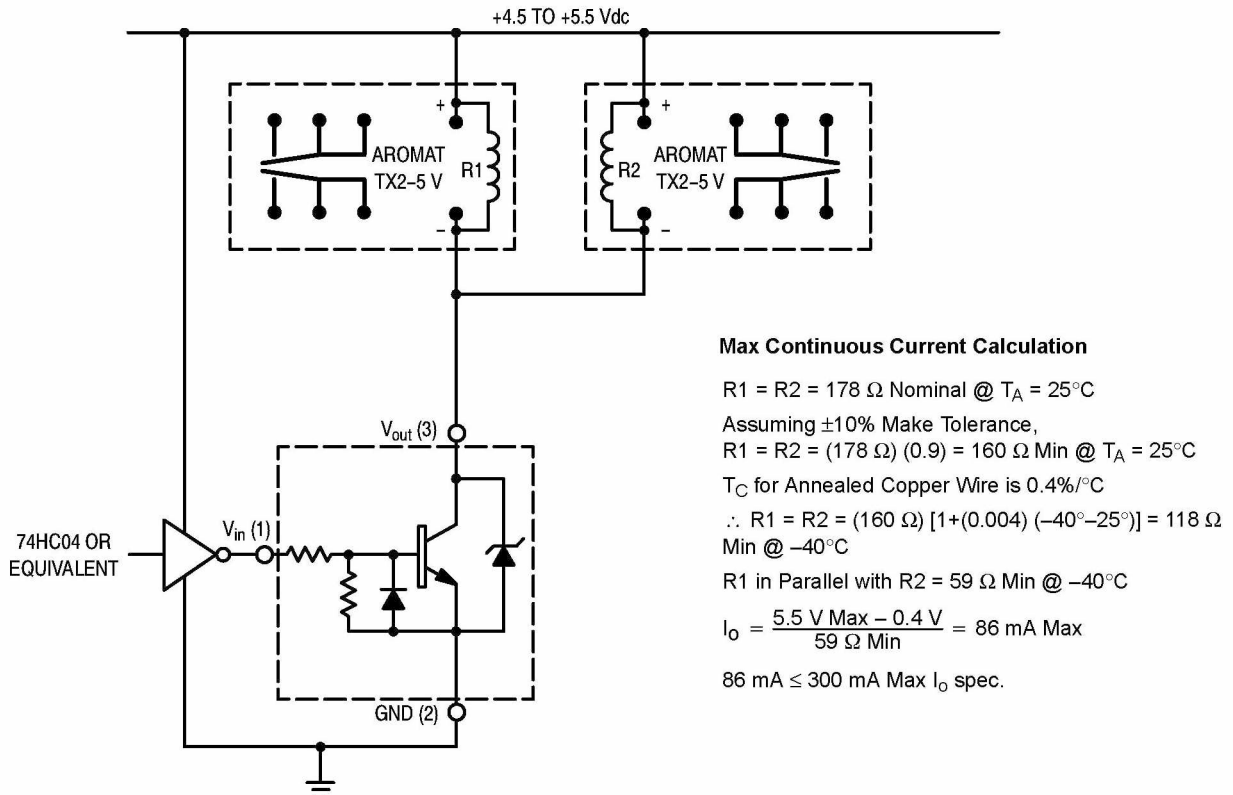

Figure 5. Typical 5.0 V, 140 mW Coil Dual Relay Application

TYPICAL OPERATING WAVEFORMS

(Circuit of Figure 5)

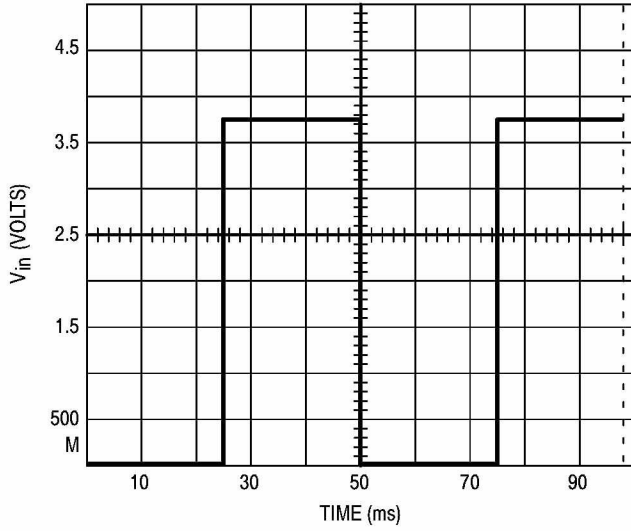

Figure 6. 20 Hz Square Wave Input

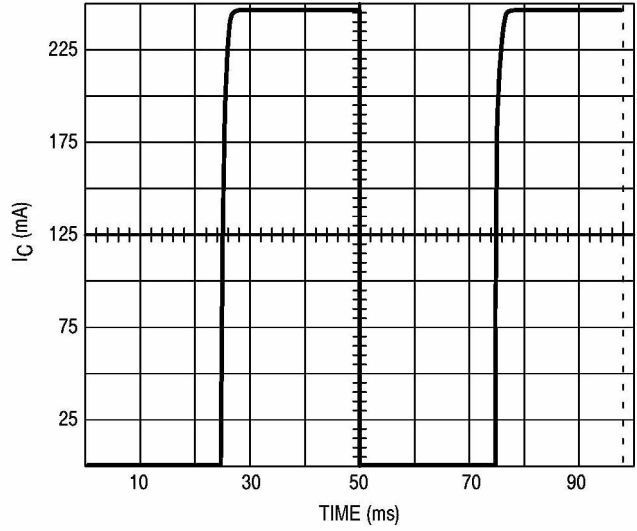

Figure 7. 20 Hz Square Wave Response

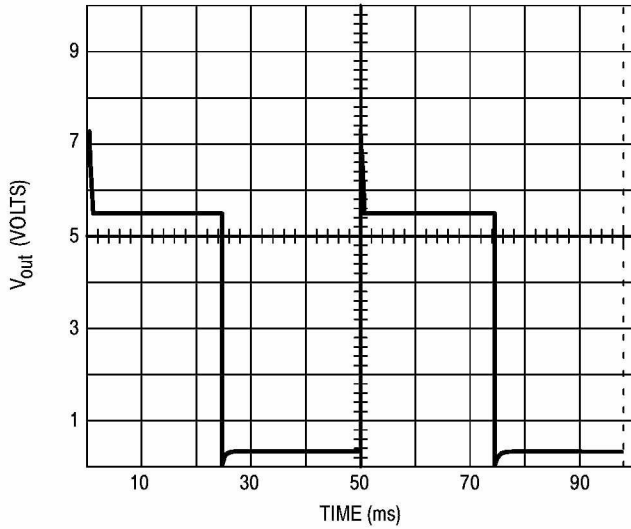

Figure 8. 20 Hz Square Wave Response

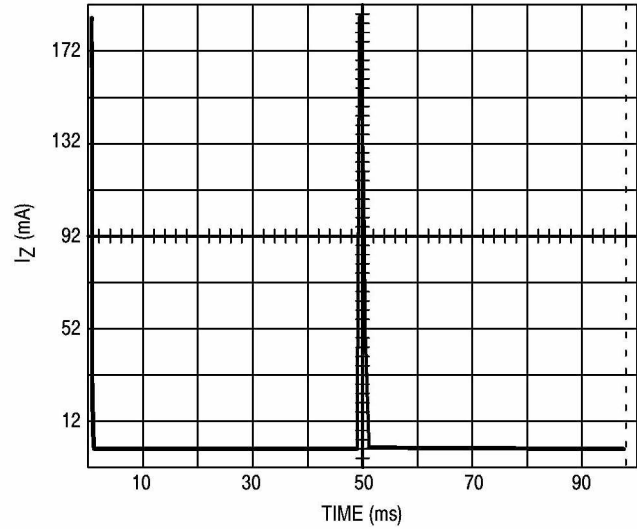

Figure 9. 20 Hz Square Wave Response

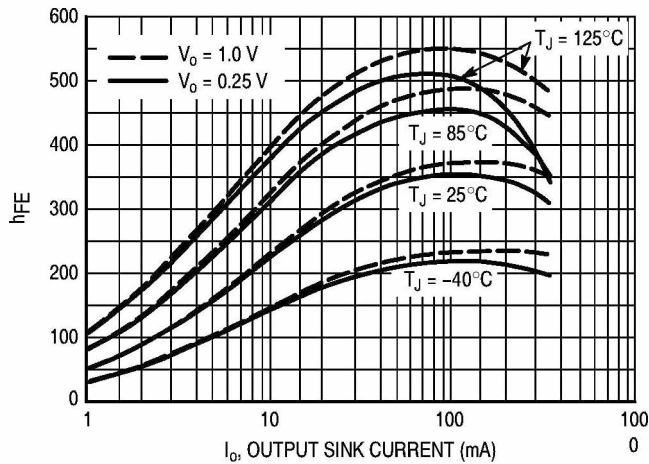

Figure 10. Pulsed Current Gain

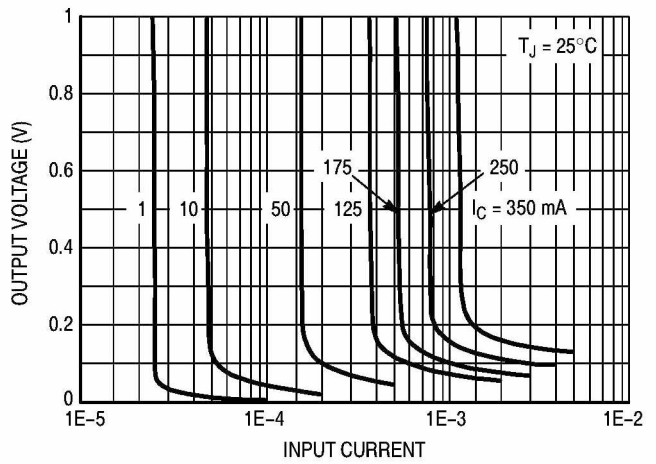

Figure 11. Collector Saturation Region