

PRELIMINARY DATA SHEET

# MSP 3415D Multistandard Sound Processor

Edition Jan. 15, 1998  
6251-438-2PD

 **MICRONAS**  
**INTERMETALL**

---

**Contents**

<b>Page</b>	<b>Section</b>	<b>Title</b>
<b>5</b>	<b>1.</b>	<b>Introduction</b>
5	1.1.	MSP 3415D Features
5	1.2.	Unsupported MSP 3410D Functions
5	1.3.	MSP 3410D Inputs and Outputs not included in the MSP 3415D
<b>6</b>	<b>2.</b>	<b>Basic Features of the MSP 3415D</b>
6	2.1.	Demodulator and NICAM Decoder Section
6	2.2.	DSP-Section (Audio Baseband Processing)
6	2.3.	Analog Section
<b>7</b>	<b>3.</b>	<b>Application Fields of the MSP 3415D</b>
7	3.1.	NICAM plus FM/AM-Mono
7	3.2.	German 2-Carrier System (DUAL FM System)
<b>10</b>	<b>4.</b>	<b>Architecture of the MSP 3415D</b>
10	4.1.	Demodulator and NICAM Decoder Section
10	4.1.1.	Analog Sound IF – Input Section
11	4.1.2.	Quadrature Mixers
11	4.1.3.	Lowpass Filtering Block for Mixed Sound IF Signals
12	4.1.4.	Phase and AM Discrimination
12	4.1.5.	Differentiators
12	4.1.6.	Lowpass Filter Block for Demodulated Signals
12	4.1.7.	High Deviation FM Mode
12	4.1.8.	FM-Carrier-Mute Function in the Dual Carrier FM Mode
12	4.1.9.	DQPSK-Decoder
12	4.1.10.	NICAM-Decoder
13	4.2.	Analog Section
13	4.2.1.	SCART Switching Facilities
13	4.2.2.	Standby Mode
13	4.3.	DSP-Section (Audio Baseband Processing)
13	4.3.1.	Dual Carrier FM Stereo/Bilingual Detection
14	4.4.	Audio PLL and Crystal Specifications
<b>15</b>	<b>5.</b>	<b>I<sup>2</sup>C Bus Interface: Device and Subaddresses</b>
16	5.1.	Protocol Description
17	5.2.	Proposal for MSP 3415D I2C Telegrams
17	5.2.1.	Symbols
17	5.2.2.	Write Telegrams
17	5.2.3.	Read Telegrams
17	5.2.4.	Examples
18	5.3.	Start Up Sequence: Power Up and I2C-Controlling
<b>19</b>	<b>6.</b>	<b>Programming the Demodulator and NICAM Decoder Section</b>
19	6.1.	Autodetection, Short-Programming, and General Programming of the Demodulator Part
20	6.2.	Demodulator Write Registers: Table and Addresses
20	6.3.	Demodulator Read Registers: Table and Addresses
21	6.4.	Demodulator Write Registers for Short-Programming: Functions and Values
21	6.4.1.	Demodulator Short-Programming
22	6.4.2.	AUTO_FM/AM: Automatic Switching between NICAM and FM/AM-Mono

**Contents**

<b>Page</b>	<b>Section</b>	<b>Title</b>
23	6.5.	Demodulator Write Registers for the General Programming Mode: Functions and Values
23	6.5.1.	Register 'AD_CV'
25	6.5.2.	Register 'MODE_REG'
26	6.5.3.	FIR-Parameter
28	6.5.4.	DCO-Registers
28	6.6.	Demodulator Read Registers: Functions and Values
29	6.6.1.	Autodetect of Terrestrial TV-Audio Standards
30	6.6.2.	C_AD_BITS
30	6.6.3.	ADD_BITS [10:3] 0038hex
30	6.6.4.	CIB_BITS
30	6.6.5.	ERROR_RATE 0057hex
30	6.6.6.	CONC_CT (for compatibility with MSP 3410B)
31	6.6.7.	FAWCT_IST (for compatibility with MSP3410B)
31	6.6.8.	PLL_CAPS
31	6.6.9.	AGC_GAIN
31	6.7.	Sequences to Transmit Parameters and to Start Processing
33	6.8.	Software Proposals for Multistandard TV-Sets
33	6.8.1.	Multistandard Including System B/G with NICAM/FM-Mono only
33	6.8.2.	Multistandard Including System I with NICAM/FM-Mono only
33	6.8.3.	Multistandard Including System B/G with NICAM/FM-Mono and German DUAL FM
33	6.8.4.	Satellite Mode
33	6.8.5.	Automatic Search Function for FM-Carrier Detection
<b>35</b>	<b>7.</b>	<b>Programming the DSP Section (Audio Baseband Processing)</b>
35	7.1.	DSP Write Registers: Table and Addresses
36	7.2.	DSP Read Registers: Table and Addresses
36	7.3.	DSP Write Registers: Functions and Values
36	7.3.1.	Volume Loudspeaker Channel
37	7.3.2.	Balance Loudspeaker Channel
37	7.3.3.	Bass Loudspeaker Channel
38	7.3.4.	Treble Loudspeaker Channel
38	7.3.5.	Volume SCART1
39	7.3.6.	Channel Source Modes
39	7.3.7.	Channel Matrix Modes
39	7.3.8.	SCART Prescale
39	7.3.9.	FM/AM Prescale
40	7.3.10.	FM Matrix Modes
40	7.3.11.	FM Fixed Deemphasis
40	7.3.12.	FM Adaptive Deemphasis
40	7.3.13.	NICAM Prescale
40	7.3.14.	NICAM Deemphasis
40	7.3.15.	ACB Register
40	7.3.16.	Beeper
41	7.3.17.	Identification Mode
41	7.3.18.	FM DC Notch
41	7.3.19.	Automatic Volume Correction (AVC)
42	7.4.	Exclusions for the Audio Baseband Features

---

**Contents**

<b>Page</b>	<b>Section</b>	<b>Title</b>
42	7.5.	DSP Read Registers: Functions and Values
42	7.5.1.	Stereo Detection Register
42	7.5.2.	Quasi-Peak Detector
42	7.5.3.	DC Level Register
<b>43</b>	<b>8.</b>	<b>Specifications</b>
43	8.1.	Outline Dimensions
44	8.2.	Pin Connections and Short Descriptions
48	8.3.	Pin Configurations
50	8.4.	Pin Circuits
52	8.5.	Electrical Characteristics
52	8.5.1.	Absolute Maximum Ratings
53	8.5.2.	Recommended Operating Conditions
56	8.5.3.	Characteristics
<b>61</b>	<b>9.</b>	<b>Application Circuit</b>
<b>64</b>	<b>10.</b>	<b>Appendix A: MSP 3415D Version History</b>
<b>64</b>	<b>11.</b>	<b>Data Sheet History</b>

## Multistandard Sound Processor

**Release Notes:** The hardware description in this document is valid for the MSP 3415D version A1. Revision bars indicate significant changes to the previous edition.

### 1. Introduction

The **MSP 3415D** is designed as a single-chip Multistandard Sound Processor for applications in analog and digital TV sets, video recorders, and PC-cards. As a shrink down version of the MSP3410D, the MSP 3415D combines all demodulator features of the MSP3410D with less I/O and reduced audio baseband processing.

The IC is produced in submicron CMOS technology, combined with high performance digital signal processing. The MSP 3415D is available in a PLCC68, PSDIP64, PSDIP52, and in a QFP80 package.

**Note:** The MSP 3415D version has reduced control registers and less functional pins. The remaining registers are software compatible to the MSP 3410D. The pinning is compatible to the MSP 3410D.

#### 1.1. MSP 3415D Features

- Sound IF input
- No external filters required
- Stereo baseband input via integrated AD converters
- Two pairs of DA converters
- Two carrier FM or NICAM processing
- AVC: Automatic Volume Correction
- Bass, treble, volume processing
- Full SCART in/out matrix without restrictions
- Improved FM-identification (as in MSPC)

- Demodulator short programming
- Autodetection for terrestrial TV-sound standards
- Precise bit-error rate indication
- Automatic switching from NICAM to FM/AM or vice versa
- Improved NICAM synchronization algorithm (as in MSPD)
- Improved carrier mute algorithm (as in MSPD)
- Improved AM-demodulation (as in MSPD)
- Reduction of necessary controlling
- Less external components

#### 1.2. Unsupported MSP 3410D Functions

- Equalizer
- Spatial Effect
- Pseudo Stereo
- Loudness

#### 1.3. MSP 3410D Inputs and Outputs not included in the MSP 3415D

- 2nd IF input
- 3rd and 4th SCART input
- 2nd SCART output
- 2nd SCART DA
- Headphone output
- Subwoofer output
- I2S Interface
- ADR interface
- Digital control output pins D\_CTR\_OUT0/1

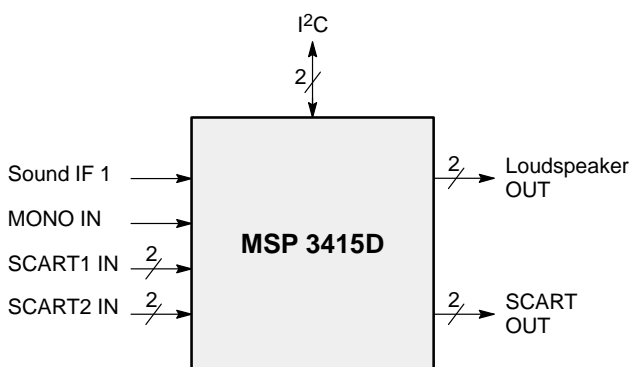

**Fig. 1–1:** Main I/O Signals MSP 3415D

## 2. Basic Features of the MSP 3415D

### 2.1. Demodulator and NICAM Decoder Section

The MSP 3415D is designed to simultaneously perform digital demodulation and decoding of NICAM-coded TV stereo sound, as well as demodulation of FM or AM-mono TV sound. Alternatively, two carrier FM systems according to the German terrestrial specs can be processed with the MSP 3415D.

The MSP 3415D facilitates profitable multistandard capability, offering the following advantages:

- Automatic Gain Control (AGC) for analog input: input range: 0.10 – 3 Vpp
- integrated A/D converter for sound-IF input
- all demodulation and filtering is performed on chip and is individually programmable
- easy realization of all digital NICAM standards (B/G, I, L and D/K)
- FM-demodulation of all terrestrial standards (incl. identification decoding)
- no external filter hardware is required
- only one crystal clock (18.432 MHz) is necessary
- high deviation FM-mono mode (max. deviation: approx.  $\pm 360$  kHz)

### 2.2. DSP-Section (Audio Baseband Processing)

- flexible selection of audio sources to be processed
- performance of terrestrial deemphasis systems (FM, NICAM)
- digitally performed FM-identification decoding and de-matrixing
- digital baseband processing: volume, bass, treble
- simple controlling of volume, bass, treble

### 2.3. Analog Section

- two selectable analog pairs of audio baseband inputs (= two SCART inputs)  
input level:  $\leq 2$  V RMS,  
input impedance:  $\geq 25$  k $\Omega$
- one selectable analog mono input (i.e. AM sound):  
input level:  $\leq 2$  V RMS,  
input impedance:  $\geq 15$  k $\Omega$
- two high-quality A/D converters, S/N-Ratio:  $\geq 85$  dB
- 20 Hz to 20 kHz bandwidth for SCART-to-SCART-copy facilities
- loudspeaker: one pair of four-fold oversampled D/A-converters  
output level per channel: max. 1.4 VRMS  
output resistance: max. 5 k $\Omega$   
S/N-ratio:  $\geq 85$  dB at maximum volume  
max. noise voltage in mute mode:  $\leq 10$   $\mu$ V  
(BW: 20 Hz ... 16 kHz)
- one pair of four-fold oversampled D/A converters supplying a pair of SCART-outputs.  
output level per channel: max. 2 V RMS,  
output resistance: max. 0.5 k $\Omega$ ,  
S/N-Ratio:  $\geq 85$  dB (20 Hz... 16 kHz)

### 3. Application Fields of the MSP 3415D

In the following sections, a brief overview about the two main TV sound standards, NICAM 728 and German FM-Stereo, demonstrates the complex requirements of a multistandard audio IC.

#### 3.1. NICAM plus FM/AM-Mono

According to the British, Scandinavian, Spanish, and French TV-standards, high-quality stereo sound is transmitted digitally. The systems allow two high-quality digital sound channels to be added to the already existing FM/AM-channel. The sound coding follows the format of the so-called Near Instantaneous Companding System (NICAM 728). Transmission is performed using Differential Quadrature Phase Shift Keying (DQPSK). Table 3–2 gives some specifications of the sound coding (NICAM); Table 3–3 offers an overview of the modulation parameters.

In the case of NICAM/FM (AM) mode, there are three different audio channels available: NICAM A, NICAM B, and FM/AM-mono. NICAM A and B may belong either to a stereo or to a dual language transmission. Information about operation mode and about the quality of the NICAM signal can be read by the CCU via the control bus. In the case of low quality (high bit error rate), the CCU may decide to switch to the analog FM/AM-mono sound. Alternatively, an automatic NICAM-FM/AM switching may be applied.

#### 3.2. German 2-Carrier System (DUAL FM System)

Since September 1981, stereo and dual sound programs have been transmitted in Germany using the 2-carrier system. Sound transmission consists of the already existing first sound carrier and a second sound carrier additionally containing an identification signal. More details of this standard are given in Tables 3–1 and 3–4. For D/K and M-Korea, very similar systems are used.

**Table 3–1:** TV standards

TV-System	Position of Sound Carrier /MHz	Sound Modulation	Color System	Country
B/G	5.5/5.7421875	FM-Stereo	PAL	Germany
B/G	5.5/5.85	FM-Mono/NICAM	PAL	Scandinavia, Spain
L	6.5/5.85	AM-Mono/NICAM	SECAM-L	France
I	6.0/6.552	FM-Mono/NICAM	PAL	UK
D/K	6.5 /6.2578125 D/K1	FM-Stereo	SECAM-East	USSR
	6.5/6.7421875 D/K2 6.5/5.85 D/K-NICAM	FM-Mono/NICAM		Hungary
M M-Korea	4.5 4.5/4.724212	FM-Mono FM-Stereo	NTSC	USA Korea
Satellite Satellite	6.5 7.02/7.2	FM-Mono FM-Stereo	PAL PAL	Europe (ASTRA) Europe (ASTRA)

**Table 3–2:** Summary of NICAM 728 sound coding characteristics

Characteristics	Values
Audio sampling frequency	32 kHz
Number of channels	2
Initial resolution	14 bit/sample
Companding characteristics	near instantaneous, with compression to 10 bits/sample in 32-samples (1 ms) blocks
Coding for compressed samples	2's complement
Preemphasis	CCITT Recommendation J.17 (6.5 dB attenuation at 800 Hz)
Audio overload level	+12 dBm measured at the unity gain frequency of the preemphasis network (2 kHz)

**Table 3–3:** Summary of NICAM 728 sound modulation parameters

Specification	I	B/G	L		D/K	
Carrier frequency of digital sound	6.552 MHz	5.85 MHz	5.85 MHz		5.85 MHz	
Transmission rate	728 kBit/s					
Type of modulation	Differentially encoded quadrature phase shift keying (DQPSK)					
Spectrum shaping Roll-off factor	by means of Roll-off filters					
	1.0	0.4	0.4		0.4	
Carrier frequency of analog sound component	6.0 MHz FM mono	5.5 MHz FM mono	6.5 MHz AM mono terrestrial   cable		6.5 MHz FM mono	
Power ratio between vision carrier and analog sound carrier	10 dB	13 dB	10 dB	16 dB	13 dB	
Power ratio between analog and modulated digital sound carrier	10 dB	7 dB	17 dB	11 dB	Hungary	Poland
					12 dB	7 dB



**Table 3-4:** Key parameters for B/G, D/K, and M 2-carrier sound system

Sound Carriers	Carrier FM1			Carrier FM2		
	B/G	D/K	M	B/G	D/K	M
Vision/sound power difference	13 dB			20 dB		
Sound bandwidth	40 Hz to 15 kHz					
Pre-emphasis	50 μs		75 μs	50 μs		75 μs
Frequency deviation	±50 kHz		±25 kHz	±50 kHz		±25 kHz
<b>Sound Signal Components</b>						
Mono transmission	mono			mono		
Stereo transmission	(L+R)/2		(L+R)/2	R	(L-R)/2	
Dual sound transmission	language A			language B		
<b>Identification of Transmission Mode on Carrier FM2</b>						
Pilot carrier frequency in kHz				54.6875	55.0699	
Type of modulation				AM		
Modulation depth				50%		
Modulation frequency				mono: unmodulated		
				stereo: 117.5 Hz	149.9 Hz	
				dual: 274.1 Hz	276.0 Hz	

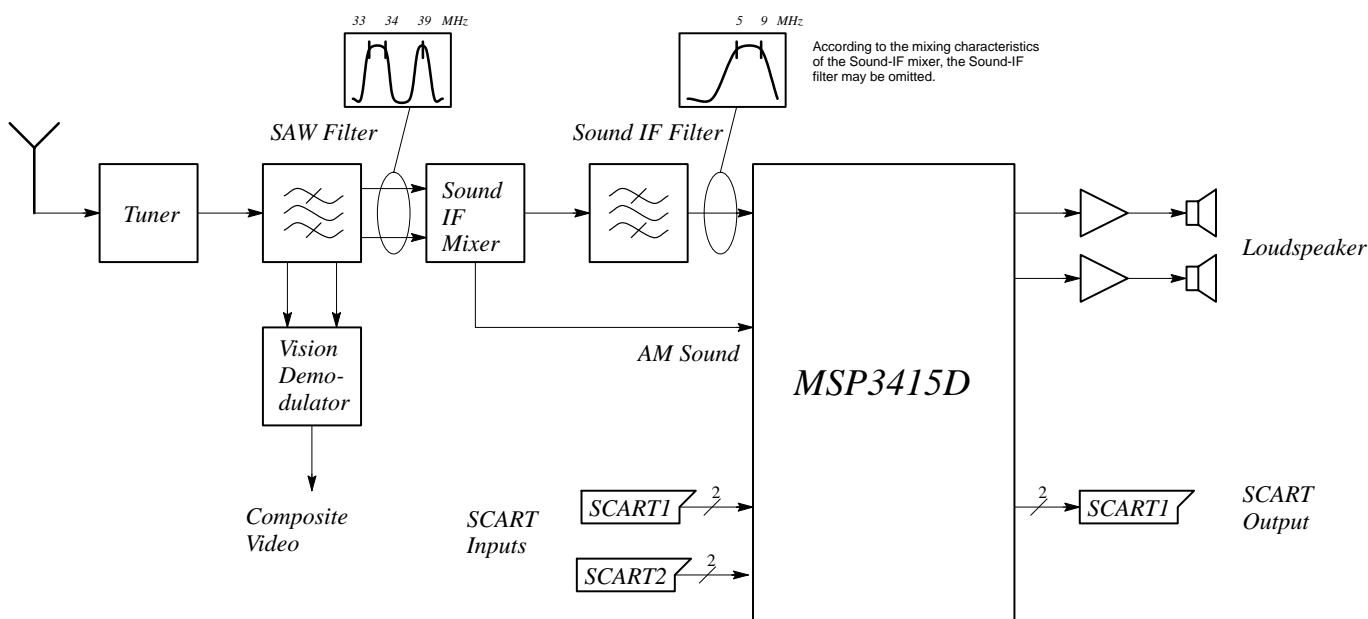

**Fig. 3-1:** Typical MSP 3415D application

4. Architecture of the MSP 3415D

Fig. 4–1 shows a simplified block diagram of the IC. Its architecture is split into three main functional blocks:

1. demodulator and NICAM decoder section
2. DSP (digital signal processing) section performing audio baseband processing
3. analog section containing two A/D-converters, four D/A-converters, and SCART-switching facilities.

4.1. Demodulator and NICAM Decoder Section

4.1.1. Analog Sound IF – Input Section

The input pins ANA\_IN1+ and ANA\_IN– offer the possibility to connect sound IF (SIF) sources to the MSP 3415D. The analog-to-digital conversion of the preselected sound IF signal is done by an A/D-converter, whose output can be used to control an analog automatic gain circuit (AGC), providing an optimal level for a wide range of input levels. It is possible to switch between automatic gain control and a fixed (setable) input gain. In the optimal case, the input range of the A/D converter is completely covered by the sound IF source. Some combinations of SAW filters and sound IF mixer ICs, however, show large picture components on their outputs. In this case, filtering is recommended. It was found, that the high pass filters formed by the coupling capacitors at pin ANA\_IN1+ (as shown in the application diagram) are sufficient in most cases.

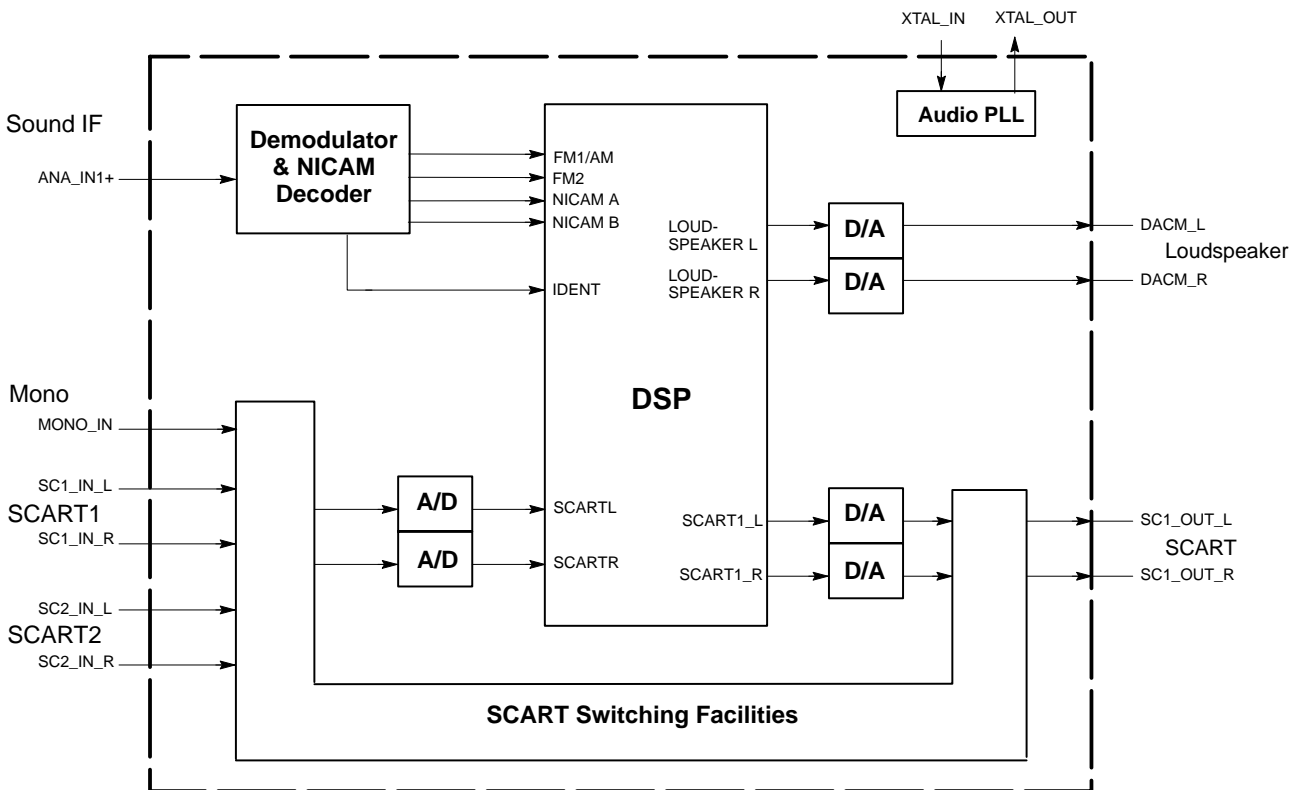

Fig. 4–1: Architecture of the MSP 3415D

**4.1.2. Quadrature Mixers**

The digital input coming from the integrated A/D converter may contain audio information at a frequency range of theoretically 0 to 9 MHz corresponding to the selected standards. By means of two programmable quadrature mixers, two different audio sources; for example, NICAM and FM-mono, may be shifted into baseband position. In the following, the two main channels are provided to process either:

- NICAM (MSP-Ch1) and FM/AM mono (MSP-Ch2) simultaneously or, alternatively,
- FM2 (MSP-Ch1) and FM1 (MSP-Ch2).

Two programmable registers, to be divided up into Low and High Part, determine frequency of the oscillator, which corresponds to the frequency of the desired audio carrier. In section 6.2., format and values of the registers are listed.

**4.1.3. Lowpass Filtering Block for Mixed Sound IF Signals**

Data shaping and/or FM bandwidth limitation is performed by a linear phase Finite Impulse Response (FIR-filter). Just like the oscillators' frequency, the filter coefficients are programmable and are written into the IC by the CCU via the control bus. Thus, for example, different NICAM versions can easily be implemented. Two not necessarily different sets of coefficients are required, one for MSP-Ch1 (NICAM or FM2) and one for MSP-Ch2 (FM1 = FM-mono). In section 6.5.3., several coefficient sets are proposed.

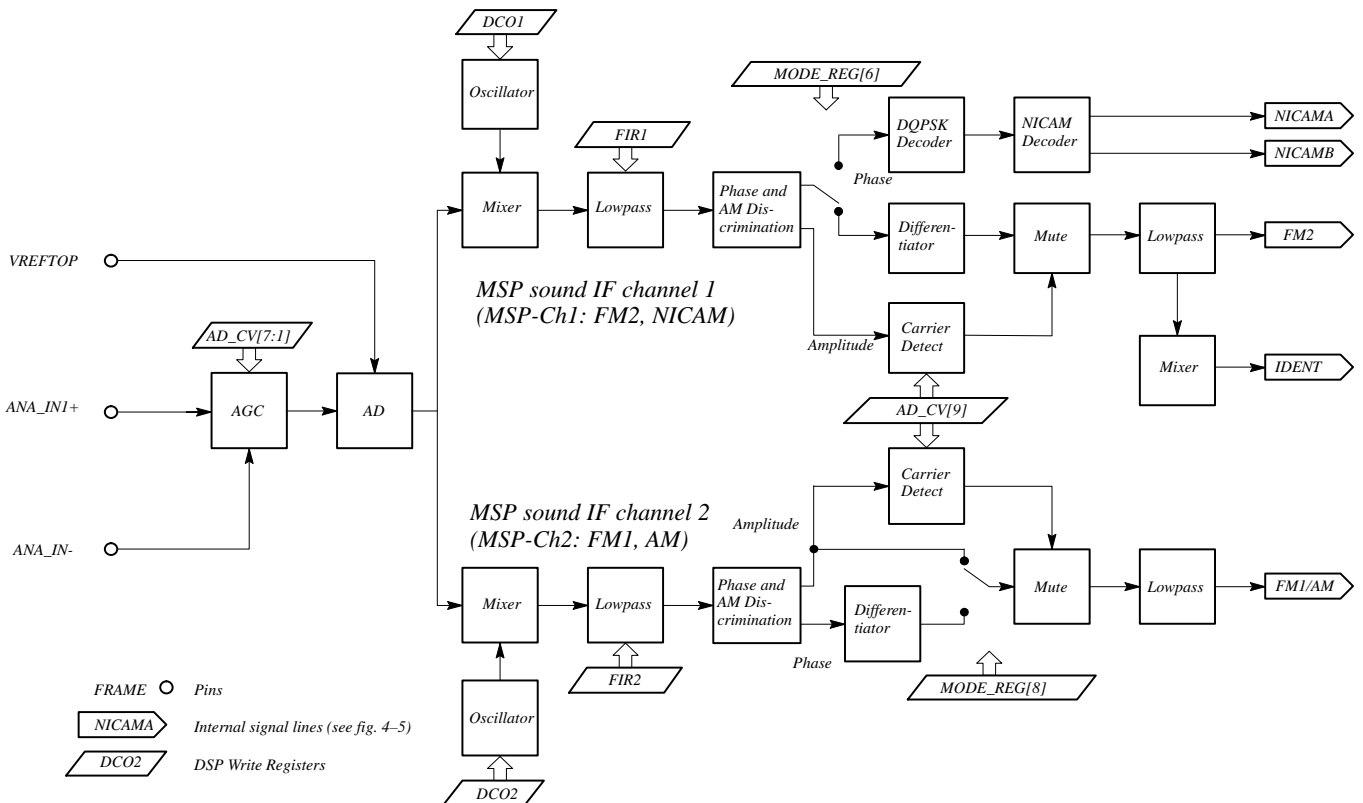

**Fig. 4-2: Demodulator architecture**

#### 4.1.4. Phase and AM Discrimination

The filtered sound IF signals are demodulated by means of the phase and amplitude discriminator block. On the output, the phase and amplitude is available for further processing. AM signals are derived from the amplitude information, whereas the phase information serves for FM and NICAM (DQPSK) demodulation.

#### 4.1.5. Differentiators

FM demodulation is completed by differentiating the phase information output.

#### 4.1.6. Lowpass Filter Block for Demodulated Signals

The demodulated FM and AM signals are further low-pass filtered and decimated to a final sampling frequency of 32 kHz. The usable bandwidth of the final baseband signals is about 15 kHz.

#### 4.1.7. High Deviation FM Mode

By means of MODE\_REG [9], the maximum FM-deviation can be extended to approximately  $\pm 360$  kHz. Since this mode can be applied only for the MSP sound IF channel 2, the corresponding matrices in the baseband processing must be set to sound A. Apart from this, the coefficient sets 380 kHz FIR2 or 500 kHz FIR2 must be chosen for the FIR2. In relation to the normal FM-mode, the audio level of the high-deviation mode is reduced by 6 dB. The FM-prescaler should be adjusted accordingly. In high deviation FM-mode, neither FM-stereo nor FM-identification nor NICAM processing is possible simultaneously.

#### 4.1.8. FM-Carrier-Mute Function in the Dual Carrier FM Mode

To prevent noise effects or FM identification problems in the absence of one of the two FM carriers, the MSP 3415 D offers a carrier detection feature, which must be activated by means of AD\_CV[9]. If no FM carrier is available at the MSPD channel 1, the corresponding channel FM2 is muted. If no FM carrier is available at the MSPD channel 2, the corresponding channel FM1 is muted.

#### 4.1.9. DQPSK-Decoder

In case of NICAM-mode, the phase samples are decoded according the DQPSK-coding scheme. The output of this block contains the original NICAM-bitstream.

#### 4.1.10. NICAM-Decoder

Before any NICAM decoding can start, the MSP must lock to the NICAM frame structure by searching and synchronizing to the so-called Frame Alignment Words (FAW).

To reconstruct the original digital sound samples, the NICAM-bitstream has to be descrambled, deinterleaved, and rescaled. Also, bit error detection and correction (concealment) is performed in this NICAM specific block.

To facilitate the Central Control Unit CCU to switch the TV-set to the actual sound mode, control information on the NICAM mode and bit error rate are supplied by the the NICAM-Decoder. It can be read out via the I<sup>2</sup>C-Bus.

An automatic switching facility (AUTO\_FM) between NICAM and FM/AM reduces the amount of CCU-instructions in case of bad NICAM reception.

4.2. Analog Section

4.2.1. SCART Switching Facilities

The analog input and output sections include full matrix switching facilities, which are shown in Fig. 4–3.

The switches are controlled by the ACB bits defined in the audio processing interface (see section 7. Programming the DSP Section).

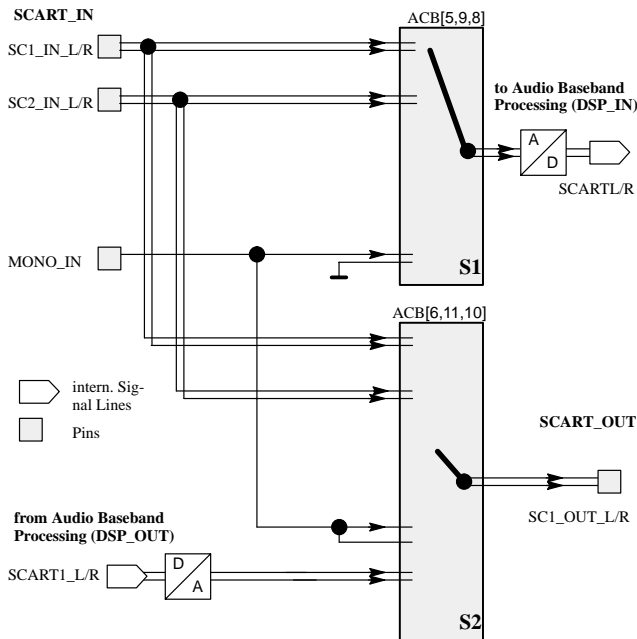

**Fig. 4–3:** SCART-Switching Facilities (s. 7.3.15.) Switch positions show the default configuration after Power On Reset. Note: SCART\_OUT is undefined after RESET!

4.2.2. Standby Mode

If the MSP 3415D is switched off by first pulling STANDBYQ low, and then disconnecting the 5 V, but keeping the 8 V power supply ('Standby'-mode), the switches S1, S2, and S3 (see Fig. 4–3) maintain their position and function. This facilitates the copying from selected SCART-inputs to SCART-outputs in the TV-set's standby mode.

In case of power-on start or starting from standby, the IC switches automatically to the default configuration, shown in Fig. 4–3. This action takes place after the first I<sup>2</sup>C transmission into the DSP part. By transmitting the ACB register first, the individual default setting mode of the TV set can be defined.

4.3. DSP-Section (Audio Baseband Processing)

All audio baseband functions are performed by digital signal processing (DSP). The DSP functions are grouped into three processing parts: input preprocessing, channel source selection, and channel postprocessing (see Fig. 4–5 and section 7.).

The input preprocessing is intended to prepare the various signals of all input sources in order to form a standardized signal at the input to the channel selector. The signals can be adjusted in volume, are processed with the appropriate deemphasis, and are dematrixed if necessary.

Having prepared the signals that way, the channel selector makes it possible to distribute all possible source signals to the desired output channels.

All input and output signals can be processed simultaneously with the exception that FM2 cannot be processed at the same time as NICAM. FM-identification and adaptive deemphasis are also not possible simultaneously.

All input and output signals can be processed simultaneously. While processing the adaptive deemphasis, no dual carrier stereo (German or Korean) is possible. Identification values are not valid either.

4.3.1. Dual Carrier FM Stereo/Bilingual Detection

For the terrestrial dual FM carrier systems, audio information can be transmitted in three modes: Mono, stereo, or bilingual. To obtain information about the current audio operation mode, the MSP 3415D detects the so-called identification signal. Information is supplied via the Stereo Detection Register to an external CCU.

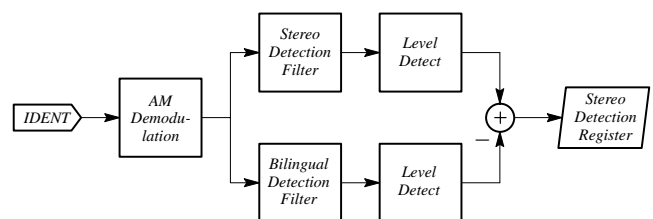

**Fig. 4–4:** Stereo/bilingual detection

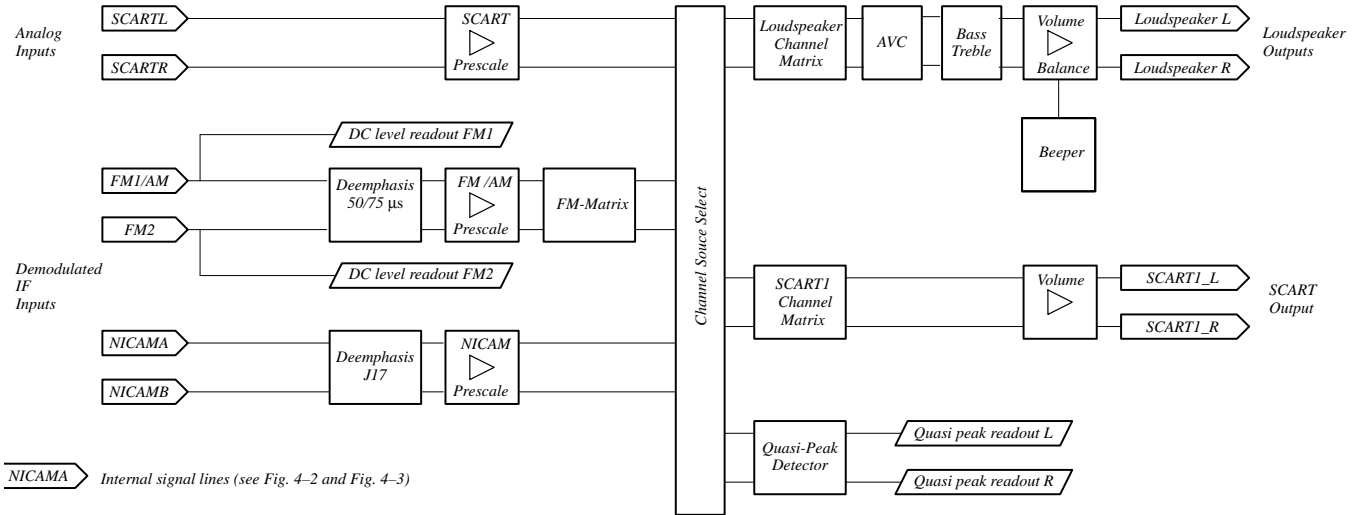

Fig. 4–5: Audio Baseband Processing (DSP-Firmware)

Table 4–1: Some examples for recommended channel assignments for demodulator and audio processing part

Mode	MSP Sound IF-Channel 1	MSP Sound IF-Channel 2	FM-Matrix	Channel-Select	Channel Matrix
B/G-Stereo	FM2 (5.74 MHz): R	FM1 (5.5 MHz): (L+R)/2	B/G Stereo	Speakers: FM	Stereo
B/G-Bilingual	FM2 (5.74 MHz): Sound B	FM1 (5.5 MHz): Sound A	No Matrix	Speakers: FM H. Phone: FM	Speakers: Sound A H. Phone: Sound B
NICAM-I-ST/ FM-mono	NICAM (6.552 MHz)	FM (6.0 MHz): mono	No Matrix	Speakers: NICAM H. Phone: FM	Speakers: Stereo H. Phone: Sound A
Sat-Mono	not used	FM (6.5 MHz): mono	No Matrix	Speakers: FM	Sound A
Sat-Stereo	7.2 MHz: R	7.02 MHz: L	No Matrix	Speakers: FM	Stereo
Sat-Bilingual	7.38 MHz: Sound C	7.02 MHz: Sound A	No Matrix	Speakers: FM H. Phone: FM	Speakers: Sound A H. Phone: Sound B=C
Sat-High Dev. Mode	don't care	6.552 MHz	No Matrix	Speakers: FM H. Phone: FM	Speakers: Sound A H. Phone: Sound A

4.4. Audio PLL and Crystal Specifications

The MSP 3415D requires a 18.432 MHz (12 pF, parallel) crystal. The clock supply of the whole system depends on the MSP 3415D operation mode:

1. FM-Stereo, FM-Mono:  
The system clock runs free on the crystal's 18.432 MHz.
2. NICAM:  
An integrated clock PLL uses the 364 kHz baud-rate, accomplished in the NICAM demodulator block, to lock the system clock to the bit rate, respectively, 32 kHz sam-

pling rate of the NICAM transmitter. As a result, the whole audio system is supplied with a controlled 18.432 MHz clock.

Remark on using the crystal:

External capacitors at each crystal pin to ground are required. They are necessary for tuning the open-loop frequency of the internal PLL and for stabilizing the frequency in closed-loop operation. The higher the capacitors, the lower the clock frequency results. The nominal free running frequency should match the center of the tolerance range between 18.433 and 18.431 MHz as closely as possible.

## 5. I<sup>2</sup>C Bus Interface: Device and Subaddresses

As a slave receiver, the MSP 3415D can be controlled via I<sup>2</sup>C bus. Access to internal memory locations is achieved by subaddressing. The demodulator and the DSP processor parts have two separate subaddressing register banks.

In order to allow for more MSP 3415D ICs to be connected to the control bus, an ADR\_SEL pin has been implemented. With ADR\_SEL pulled to high, low, or left open, the MSP 3415D responds to changed device addresses. Thus, three identical devices can be selected.

By means of the RESET bit in the CONTROL register, all devices with the same device address are reset.

The IC is selected by asserting a special device address in the address part of an I<sup>2</sup>C transmission. A device address pair is defined as a write address (80 hex, 84 hex, or 88 hex) and a read address (81 hex, 85 hex, or 89 hex). Writing is done by sending the device write address first, followed by the subaddress byte, two address bytes, and two data bytes. For reading, the read address has to be transmitted first by sending the device write address (80 hex, 84 hex, or 88 hex) followed by the subaddress byte and two address bytes. Without sending a stop condition, reading of the addressed data is done by sending the device read address (81 hex, 85 hex, or 89 hex) and reading two bytes of data. Refer

to Fig. 5–1: I<sup>2</sup>C Bus Protocol and section 5.2. Proposal for MSP 3415D I<sup>2</sup>C Telegrams.

Due to the internal architecture of the MSP 3415D the IC cannot react immediately to an I<sup>2</sup>C request. The typical response time is about 0.3 ms for the DSP processor part and 1 ms for the demodulator part if NICAM processing is active. If the receiver (MSP) can't receive another complete byte of data until it has performed some other function; for example, servicing an internal interrupt, it can hold the clock line I<sup>2</sup>C\_CL LOW to force the transmitter into a wait state. The positions within a transmission where this may happen are indicated by 'Wait' in section 5.1. The maximum Wait-period of the MSP during normal operation mode is less than 1 ms.

I<sup>2</sup>C-Bus error conditions:

In case of any internal error, the MSP's wait-period is extended to 1.8 ms. Afterwards, the MSP does not acknowledge (NAK) the device address. The data line will be left HIGH by the MSP and the clock line will be released. The master can then generate a STOP condition to abort the transfer.

By means of NAK, the master is able to recognize the error state and to reset the IC via I<sup>2</sup>C-Bus. While transmitting the reset protocol (s. 5.2.4.) to 'CONTROL', the master must ignore the not acknowledge bits (NAK) of the MSP.

A general timing diagram of the I<sup>2</sup>C Bus is shown in Fig. 5–2.

**Table 5–1:** I<sup>2</sup>C Bus Device Addresses

ADR_SEL	Low		High		Left Open	
	Write	Read	Write	Read	Write	Read
MSP device address	80 hex	81 hex	84 hex	85 hex	88 hex	89 hex

**Table 5–2:** I<sup>2</sup>C Bus Subaddresses

Name	Binary Value	Hex Value	Mode	Function
CONTROL	0000 0000	00	W	software reset
TEST	0000 0001	01	W	only for internal use
WR_DEM	0001 0000	10	W	write address demodulator
RD_DEM	0001 0001	11	W	read address demodulator
WR_DSP	0001 0010	12	W	write address DSP
RD_DSP	0001 0011	13	W	read address DSP

**Table 5-3:** Control Register (Subaddress: 00 hex)

Name	Subaddress	MSB	14	13..1	LSB
CONTROL	00 hex	1 : RESET 0 : normal	0	0	0

**5.1. Protocol Description**

**Write to DSP or Demodulator**

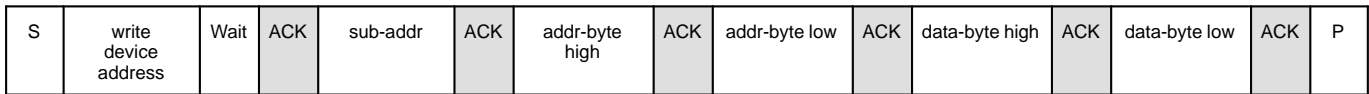

**Read from DSP or Demodulator**

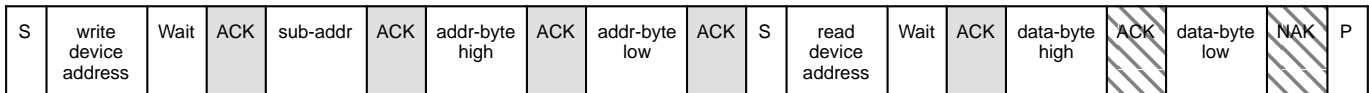

**Write to Control or Test Registers**

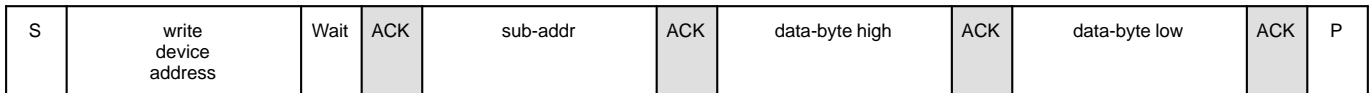

- Note:** S = I<sup>2</sup>C-Bus Start Condition from master  
 P = I<sup>2</sup>C-Bus Stop Condition from master  
 ACK = Acknowledge-Bit: LOW on I<sup>2</sup>C\_DA from slave (=MSP, grey) or master (=CCU, hatched)  
 NAK = Not Acknowledge-Bit: HIGH on I<sup>2</sup>C\_DA from master (=CCU, hatched) to indicate 'End of Read' or from MSP indicating internal error state  
 Wait = I<sup>2</sup>C-Clock line held low by the slave (=MSP) while interrupt is serviced (<1.8 ms)

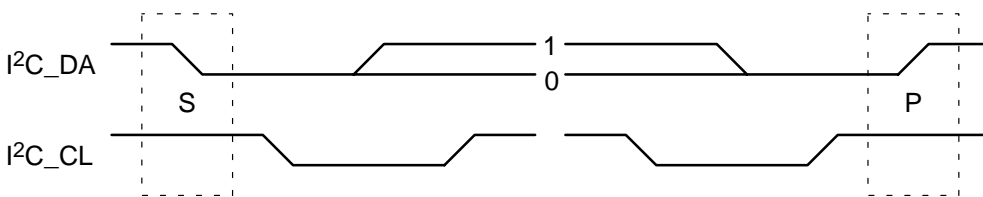

**Fig. 5-1:** I<sup>2</sup>C bus protocol (MSB first; data must be stable while clock is high)

(Data: MSB first)



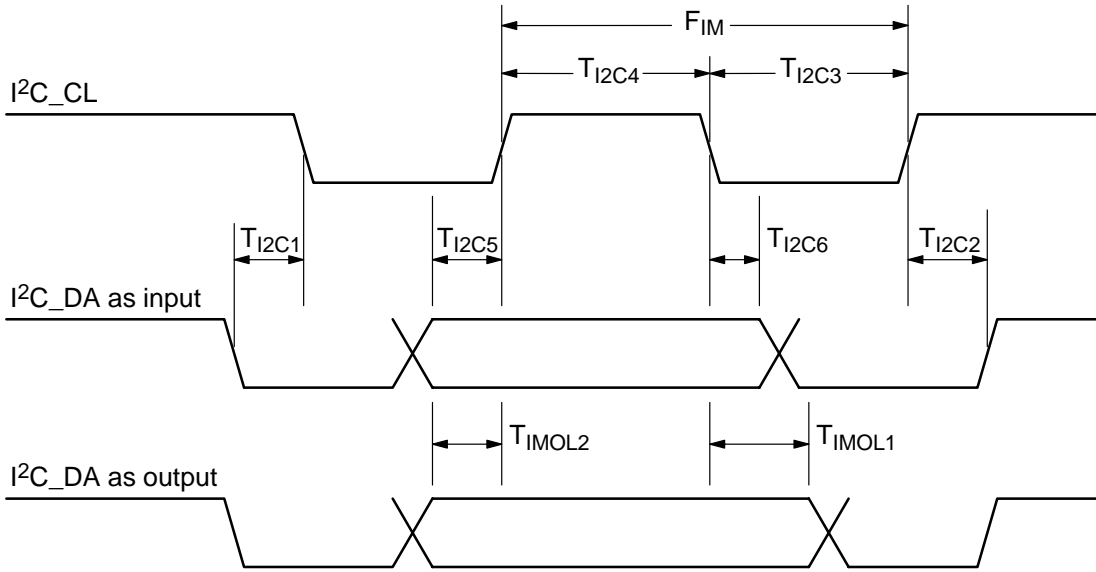

Fig. 5–2: I<sup>2</sup>C bus timing diagram

## 5.2. Proposal for MSP 3415D I<sup>2</sup>C Telegrams

### 5.2.1. Symbols

daw write device address  
 dar read device address  
 < Start Condition  
 > Stop Condition  
 aa Address Byte  
 dd Data Byte

### 5.2.2. Write Telegrams

<daw 00 d0 00> write to CONTROL register  
 <daw 10 aa aa dd dd> write data into demodulator  
 <daw 12 aa aa dd dd> write data into DSP

### 5.2.3. Read Telegrams

<daw 11 aa aa <dar dd dd> read data from demodulator  
 <daw 13 aa aa <dar dd dd> read data from DSP

### 5.2.4. Examples

<80 00 80 00> RESET MSP statically  
 <80 00 00 00> clear RESET  
 <80 12 00 08 01 20> set loudspeaker channel source to NICAM and Matrix to STEREO

5.3. Start Up Sequence: Power Up and I<sup>2</sup>C-Controlling

After power on or RESET (see Fig. 5–3), the IC is in an inactive state. The CCU has to transmit the required coefficient set for a given operation via the I<sup>2</sup>C bus. Initialization should start with the demodulator part. If required for any reason, the audio processing part can be loaded before the demodulator part.

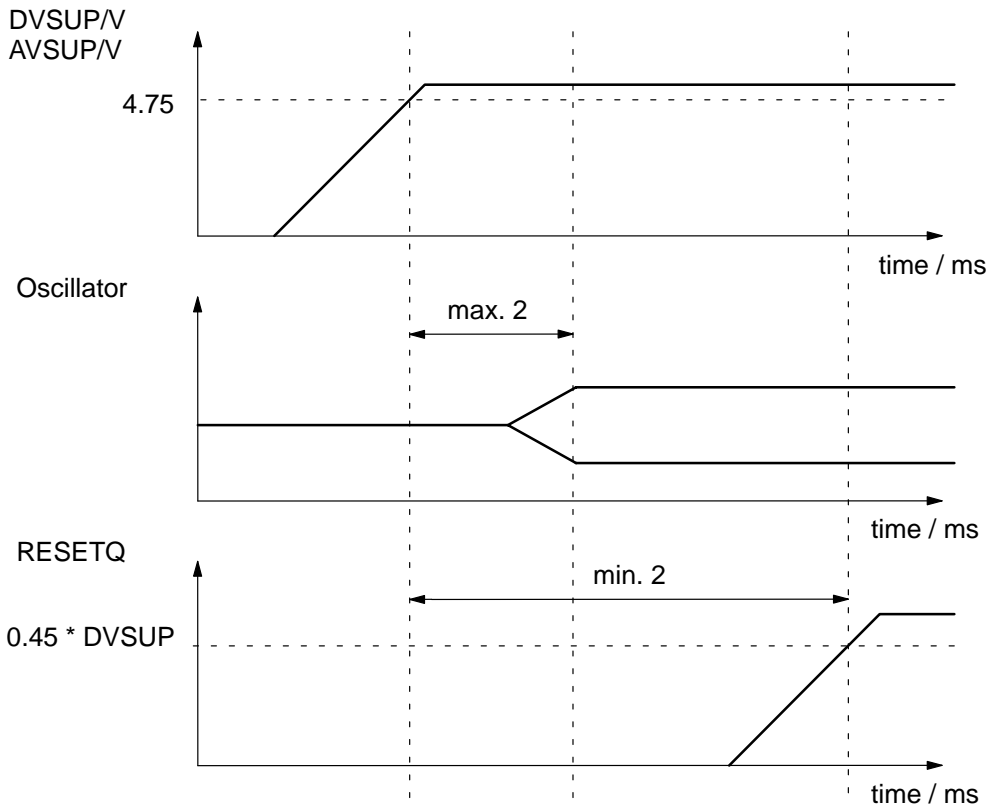

Fig. 5–3: Power-up sequence

**Note:** The reset should not reach high level before the oscillator has started. This requires a reset delay of >2 ms

---

## 6. Programming the Demodulator and NICAM Decoder Section

### 6.1. Autodetection, Short-Programming, and General Programming of the Demodulator Part

The Demodulator Part of the MSP 3415D can be programmed in **three different modes**:

**1. Autodetection for terrestrial TV-Standards** (as part of the below Demodulator Short-Programming) provides the most comfortable way to set up the MSPD-demodulator. This feature facilitates within 0.5 s the detection and set-up of the actual TV-sound standard. Since the detected standard is readable by the control processor, the autodetection feature is mainly recommended for the primary set-up of a TV-set: after having determined once the corresponding TV-channels, their sound standards can be stored and later on programmed by the Demodulator Short-Programming (see sections 6.4.1. and 6.6.1.).

**2. Demodulator Short-Programming** facilitates a comfortable way to set up the demodulator for many terrestrial TV-sound standards with one single I<sup>2</sup>C-Bus transmission. The coding is listed in section 6.4.1.. If a parameter doesn't coincide with the individual programming concept, it simply can be overwritten by using the General Programming mode. Some bits of the registers AD\_CV (see section 6.5.1. ) and MODE\_REG (see section 6.5.2. ) are not affected by the short-programming. They must be transmitted once if their reset status does not fit. The Demodulator Short-Programming is not compatible to MSP 3410B and MSP 3400C.

**3. General Programming** ensures the software compatibility to other MSPs. It offers a very flexible way to apply all of the MSP 3415D demodulator facilities. All registers except 0020hex have to be written with values corresponding to the individual requirements. For satellite applications, with their many variations, this mode must be selected.

All transmissions on the control bus are 16 bits wide. However, data for the demodulator part have only 8 or 12 significant bits. These data have to be inserted LSB-bound and filled with zero bits into the 16-bit transmission word. Table 4–1 explains how to assign FM carriers to the MSP-Sound IF channels and the corresponding matrix modes in the audio processing part.

## 6.2. Demodulator Write Registers: Table and Addresses

**Table 6–1:** Demodulator Write Registers; Subaddress: 10 hex; these registers are not readable!

Demodulator Write Registers	Address (hex)	Function
Demodulator Short-Programming	0020	Write into this register to apply Demodulator Short Programming (see section 6.4.1.). If the internal setting coincidences with the individual requirements no more of the remaining Demodulator Write Registers have to be transferred.
AUTO_FM/AM	0021	Only for NICAM: Automatic switching between NICAM and FM/AM in case of bad NICAM reception (see section 6.4.2.)
Write Registers necessary for <b>General Programming Mode</b> only		
AD_CV	00BB	input selection, configuration of AGC, Mute Function and selection of A/D-converter, FM-Carrier-Mute on/off
MODE_REG	0083	mode register
FIR1 FIR2	0001 0005	filter coefficients channel 1 (6 · 8 bit) filter coefficients channel 2 (6 · 8 bit), + 3 · 8 bit offset (total 72 bit)
DCO1_LO DCO1_HI	0093 009B	increment channel 1 Low Part increment channel 1 High Part
DCO2_LO DCO2_HI	00A3 00AB	increment channel 2 Low Part increment channel 2 High Part
PLL_CAPS	001F	switchable PLL capacitors to tune open-loop frequency; to use only if NICAM of MODE_REG = 0 normally not of interest for the customer

## 6.3. Demodulator Read Registers: Table and Addresses

**Table 6–2:** Demodulator Read Registers; Subaddress: 11 hex; these registers are not writeable!

Demodulator Read Registers	Address (hex)	Function
Result of Autodetection	007E	see Table 6–13
C_AD_BITS	0023	NICAM-Sync bit, NICAM-C-Bits, and three LSBs of additional data bits
ADD_BITS	0038	NICAM: bit [10:3] of additional data bits
CIB_BITS	003E	NICAM: CIB1 and CIB2 control bits
ERROR_RATE	0057	NICAM error rate, updated with 182 ms
CONC_CT	0058	only to be used in MSPB compatibility mode
FAWCT_IST	0025	only to be used in MSPB compatibility mode
PLL_CAPS	021F	Not for customer use.
AGC_GAIN	021E	Not for customer use.

## 6.4. Demodulator Write Registers for Short-Programming: Functions and Values

In the following, the functions of some registers are explained and their (default) values are defined:

### 6.4.1. Demodulator Short-Programming

**Table 6–3:** MSP 3415D Demodulator Short-Programming

Demodulator Short-Programming 0020 hex							
TV-Sound Standard		Internal Setting					
Description	Code (hex)	AD_CV <sup>2)</sup> (see Table 6–5)	MODE_REG <sup>2)</sup> (see Table 6–8)	DCO1 MHz	DCO2 MHz	FIR1/2 -Coefficients	Identification Mode
Autodetection	0001	Detects and sets one of the standards listed below, if available. Results are to be read out of the demodulator read register "Result of Autodetection" (Section 6.6.1.)					
M Dual-FM	0002	AD_CV-FM	M1	4.72421	4.5	s. Table 6–11: Terrestrial TV-Standards	Reset, then Standard M
B/G Dual-FM	0003	AD_CV-FM	M1	5.74218	5.5		Reset, then Standard B/G
D/K1 Dual-FM	0004	AD_CV-FM	M1	6.25781	6.5		
D/K2 Dual-FM	0005	AD_CV-FM	M1	6.74218	6.5		
	0006/ 0007	reserved for future Dual FM Standards					<b>AUTO_FM/AM</b>
B/G-NICAM-FM	0008	AD_CV-FM	M2	5.85	5.5	s. Table 6–11: Terrestrial TV-Standards	1)
L-NICAM-AM	0009	AD_CV-AM	M3	5.85	6.5		
I-NICAM-FM	000A	AD_CV-FM	M2	6.552	6.0		
D/K-NICAM-FM	000B	AD_CV-FM	M2	5.85	6.5		
	>000B	reserved for future NICAM Standards					
<p>1) corresponds to the actual setting of AUTO_FM (Address = 0021 hex)</p> <p>2) Bits of AD_CV or MODE_REG, which are not affected by the short-programming, must be transmitted separately if their reset status does not fit.</p>							
<p><b>Note:</b> All parameters in the DSP section (Audio Baseband Processing), except the identification mode register, are not affected by the Demodulator Short-Programming . They still have to be defined by the control processor.</p>							

#### 6.4.2. AUTO\_FM/AM: Automatic Switching between NICAM and FM/AM-Mono

In case of bad NICAM transmission or loss of the NICAM-carrier, the MSPD offers a comfortable mode to switch back to the FM/AM-mono signal. If automatic switching is active, the MSP internally evaluates the ERROR\_RATE. All output channels which are assigned to the NICAM-source are switched back to the FM/AM-mono source without any further CCU instruction, if the NICAM-carrier fails or the ERROR\_RATE exceeds the definable threshold.

Note, that the channel matrix of the corresponding output-channels must be set according to the NICAM-mode and need not be changed in the FM/AM-fall-back case. An appropriate hysteresis algorithm avoids oscillating effects. The MSB of the Register C\_AD\_BITS (Addr: 0023 hex) informs about the actual NICAM-FM/AM-Status (see section 6.6.2.).

There are two possibilities to define the threshold deciding for NICAM or FM/AM-mono (see Table 6–4):

1. default value of the MSPD (internal threshold=700, i.e. switch to FM/AM if ERROR\_RATE > 700)
2. definable by the customer (recommendable range: threshold = 50....2000, i. e. Bits [10:1] = 25...1000).

**Note:**

The auto\_fm feature is only active if the NICAM-bit of MODE\_REG is set.

To enable appropriate switching of the channel select matrix of the baseband processing part, the NICAM or FM-identification parameters must be read and evaluated by the CCU. The FM-identification registers are described in section 7.2. To handle the NICAM-sound and to observe the NICAM-quality, at least the registers C\_AD\_BITS and ERROR\_RATE must be read and evaluated by the CCU. Additional data bits and CIB bits, if supplied by the NICAM transmitter, can be obtained by reading the registers ADD\_BITS and CIB\_BITS.

**Table 6–4:** Coding of automatic NICAM-FM/AM switching; reset status: mode 0

Mode	Auto_fm [11....0] Addr. = 0021 hex	Selected Sound at the NICAM Channel Select	Threshold	Comment
0. default	Bit [0] = 0 Bits [11...1] = 0	always NICAM	none	Compatible to MSP 3410B, i.e. automatic switching is disabled
1.	Bit [0] = 1 Bit [11:1] = 0	NICAM or FM/AM, depending on ERROR_RATE	700 int	automatic switching with <b>internal</b> threshold
2.	Bit [0] = 1 Bit [10:1] = 25...1000 int = threshold/2 Bit [11] = 0	NICAM or FM/AM, depending on ERROR_RATE	set by customer	automatic switching with <b>external</b> threshold
3.	Bit [11] = [0] = 1 Bit [10...1] = 0	always FM/AM	none	Forced FM-mono mode, i.e. automatic switching is disabled

## 6.5. Demodulator Write Registers for the General Programming Mode: Functions and Values

### 6.5.1. Register 'AD\_CV'

**Table 6–5:** AD\_CV Register; reset status: all bits are "0"

AD_CV 00BB <sub>hex</sub>			Set by Short-Programming	
Bit	Meaning	Settings	AD_CV-FM	AD_CV-AM
AD_CV [0]	not used	must be set to 0	0	0
AD_CV [6:1]	Reference level in case of Automatic Gain Control = on (see Table 6–6). Constant gain factor when Automatic Gain Control = off (see Table 6–7).		101000	100011
AD_CV [7]	Determination of Automatic Gain or Constant Gain	0 = constant gain 1 = automatic gain	1	1
AD_CV [8]	not used	must be set to 0	not affected	not affected
AD_CV [9]	MSP-Carrier-Mute Function	0 = off: no mute 1 = on: mute as described in section 4.1.	1	0
AD_CV [15–10]	not used	must be set to 0	0	0

**Table 6–6:** Reference values for active AGC (AD\_CV[7] = 1)

Application	Input Signal Contains	AD_CV [6:1] Ref. Value	AD_CV [6:1] in integer	Range of Input Signal at pin ANA_IN1+ and ANA_IN2+
Terrestrial TV FM-Stereo	2 FM Carriers	101000	40	0.10 – 3 V <sub>pp</sub> <sup>1)</sup>
FM/NICAM	1 FM and 1 NICAM Carrier	101000	40	0.10 – 3 V <sub>pp</sub> <sup>1)</sup>
AM/NICAM	1 AM and 1 NICAM carrier	100011	35	0.10 – 1.4 V <sub>pp</sub> recommended: 0.10 – 0.8V <sub>pp</sub>
NICAM only	1 NICAM Carrier only	010100	20	0.05 – 1.0 V <sub>pp</sub>
SAT	1 or more FM Carriers	100011	35	0.10 – 3 V <sub>pp</sub> <sup>1)</sup>

<sup>1)</sup> For signals above 1.4 V<sub>pp</sub>, the minimum gain of 3 dB is switched, and overflow of the A/D converter may result. Due to the robustness of the internal processing, the IC works up to and even more than 3 V<sub>pp</sub>, if norm conditions of FM/NICAM or FM1/FM2 ratio are supposed. In this overflow case, a loss of FM-S/N-ratio of about 10 dB may appear.

**Table 6–7:** AD\_CV parameters for constant input gain (AD\_CV[7]=0)

Step	AD_CV [6:1] Constant Gain	Gain	Input Level at pin ANA_IN1+ and ANA_IN2+
0	000000	3.00 dB	maximum input level: 3 V <sub>pp</sub> (FM) or 1 V <sub>pp</sub> (NICAM) <sup>1)</sup>
1	000001	3.85 dB	
2	000010	4.70 dB	
3	000011	5.55 dB	
4	000100	6.40 dB	
5	000101	7.25 dB	
6	000110	8.10 dB	
7	000111	8.95 dB	
8	001000	9.80 dB	
9	001001	10.65 dB	
10	001010	11.50 dB	
11	001011	12.35 dB	
12	001100	13.20 dB	
13	001101	14.05 dB	
14	001110	14.90 dB	
15	001111	15.75 dB	
16	010000	16.60 dB	
17	010001	17.45 dB	
18	010010	18.30 dB	
19	010011	19.15 dB	
20	010100	20.00 dB	maximum input level: 0.14 V <sub>pp</sub>

<sup>1)</sup> For signals above 1.4 V<sub>pp</sub>, the minimum gain of 3 dB is switched, and overflow of the A/D converter may result. Due to the robustness of the internal processing, the IC works up to and even more than 3 V<sub>pp</sub>, if norm conditions of FM/NICAM or FM1/FM2 ratio are supposed. In this overflow case, a loss of FM-S/N-ratio of about 10 dB may appear.



### 6.5.2. Register 'MODE\_REG'

The register 'MODE\_REG' contains the control bits determining the operation mode of the MSP 3415D; Table 6–8 explains all bit positions.

**Table 6–8:** Control word 'MODE\_REG'; reset status: all bits are "0"

MODE_REG 0083 <sub>hex</sub>				Set by Short-Programming		
Bit	Function	Comment	Definition	M1	M2	M3
[0]	not used		0 : strongly recommended	0	0	0
[1]	not used		1 : recommended !	X	X	X
[2]	not used		1 : recommended !	X	X	X
[3]	not used		0 : strongly recommended	X	X	X
[4]	not used		0 : strongly recommended	X	X	X
[5]	Audio_CL_OUT	Switch Audio_Clock_Output to tri-state	0 : on 1 : tri-state	X	X	X
[6]	NICAM <sup>1)</sup>	Mode of MSP-Ch1	0 : FM 1 : Nicam	0	1	1
[7]	not used		0 : strongly recommended	0	0	0
[8]	FM AM	Mode of MSP-Ch2	0 : FM 1 : AM	0	0	1
[9]	HDEV	High Deviation Mode (channel matrix must be sound A)	0 : normal 1 : high deviation mode	0	0	0
[11:10]	not used		0 : strongly recommended	0	0	0
[12]	MSP-Ch1 Gain	see Table 6–11	0 : Gain = 6 dB 1 : Gain = 0 dB	0	0	0
[13]	FIR1-Filter Coeff. Set	see Table 6–11	0 : use FIR1 1 : use FIR2	1	0	0
[14]	not used		0 : strongly recommended	0	0	0
[15]	AM-Gain	Gain for AM Demodulation	0 : 0 dB (default. of MSPB) 1 : 12 dB (recommended)	1	1	1
				X: not affected by short-programming		

**Table 6–9:** Channel modes 'MODE\_REG [6, 8, 9]'

NICAM bit[6]	FM AM bit[8]	HDEV bit[9]	MSP-Ch1	MSP-Ch2
1	0	0	NICAM	FM1
1	1	0	NICAM	AM
0	0	0	FM2	FM1
0	0	1	--	High Deviation FM

### 6.5.3. FIR-Parameter

The following data values (see Table 6–10) are to be transferred **8 bits at a time embedded LSB-bound in a 16-bit word**.

The loading sequences must be obeyed. To change a coefficient set, the complete block FIR1 or FIR2 must be transmitted.

**Note:** For compatibility with MSP 3410B, IMREG1 and IMREG2 have to be transmitted. The value for IMREG1 and IMREG2 is 004. Due to the partitioning to 8-bit units, the values 04hex, 40hex, and 00hex arise.

**Table 6–10:** Loading sequence for FIR-coefficients

FIR1 0001 <sub>hex</sub> (MSP-Ch1: NICAM/FM2)			
No.	Symbol Name	Bits	Value
1	NICAM/FM2_Coeff. (5)	8	see Table 6–11
2	NICAM/FM2_Coeff. (4)	8	
3	NICAM/FM2_Coeff. (3)	8	
4	NICAM/FM2_Coeff. (2)	8	
5	NICAM/FM2_Coeff. (1)	8	
6	NICAM/FM2_Coeff. (0)	8	
FIR2 0005 <sub>hex</sub> (MSP-Ch2: FM1/AM )			
No.	Symbol Name	Bits	Value
1	IMREG1	8	04 HEX
2	IMREG1 / IMREG2	8	40 HEX
3	IMREG2	8	00 HEX
4	FM/AM_Coef (5)	8	see Table 6–11
5	FM/AM_Coef (4)	8	
6	FM/AM_Coef (3)	8	
7	FM/AM_Coef (2)	8	
8	FM/AM_Coef (1)	8	
9	FM/AM_Coef (0)	8	

**Table 6–11:** 8-bit FIR-coefficients (decimal integer) for MSP 3415D; reset status: all coefficients are “0”

Coefficients for FIR1 0001 <sub>hex</sub> and FIR2 0005 <sub>hex</sub>														
Coef(i)	Terrestrial TV-Standards							FM - Satellite FIR filter corresponds to a bandpass with a band-width of B = 130 to 500 kHz						
	B/G-, D/K-NICAM-FM		I-NICAM-FM		L-NICAM-AM		B/G-,D/K-, M-Dual FM	130 kHz	180 kHz	200 kHz	280 kHz	380 kHz	500 kHz	Auto-search
	FIR1	FIR2	FIR1	FIR2	FIR1	FIR2	FIR2	FIR2	FIR2	FIR2	FIR2	FIR2	FIR2	FIR2
0	-2	3	2	3	-2	-4	3	73	9	3	-8	-1	-1	-1
1	-8	18	4	18	-8	-12	18	53	18	18	-8	-9	-1	-1
2	-10	27	-6	27	-10	-9	27	64	28	27	4	-16	-8	-8
3	10	48	-4	48	10	23	48	119	47	48	36	5	2	2
4	50	66	40	66	50	79	66	101	55	66	78	65	59	59
5	86	72	94	72	86	126	72	127	64	72	107	123	126	126
MODE-REG[12]	0		0		0		0	1	1	1	1	1	1	0
MODE-REG[13]	0		0		0		1	1	1	1	1	1	1	0

For compatibility, except for the FIR2-AM and the Autosearch-sets, the FIR-filter programming as used for the MSP 3410B is also possible.

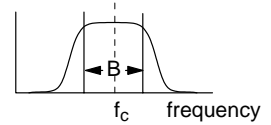

**6.5.4. DCO-Registers**

For a chosen TV standard, a corresponding set of 24-bit registers determining the mixing frequencies of the quadrature mixers, has to be written into the IC. In Table 6–12, some examples of DCO registers are listed. It is necessary to divide them up into low part and high part. The formula for the calculation of the registers for any chosen IF-Frequency is as follows:

$$INCR_{dez} = \text{int}(f/f_s \cdot 2^{24})$$

- with: int = integer function
- f = IF-frequency in MHz
- f<sub>s</sub> = sampling frequency (18.432 MHz)

Conversion of INCR into hex-format and separation of the 12-bit low and high parts lead to the required register values (DCO1\_HI or \_LO for MSP-Ch1, DCO2\_HI or LO for MSP-Ch2).

**6.6. Demodulator Read Registers: Functions and Values**

All registers except C\_AD\_BITS are 8 bit wide. They can be read out of the RAM of the MSP 3415D.

All transmissions take place in 16-bit words. The valid 8 bit data are the 8 LSBs of the received data word.

To enable appropriate switching of the channel select matrix of the baseband processing part, the NICAM or FM-identification parameters must be read and evaluated by the CCU. The FM-identification registers are described in section 7.2. To handle the NICAM-sound and to observe the NICAM-quality, at least the registers C\_AD\_BITS and ERROR\_RATE must be read and evaluated by the CCU. Additional data bits and CIB bits, if supplied by the NICAM transmitter, can be obtained by reading the registers ADD\_BITS and CIB\_BITS.

Observing the presence and quality of NICAM can be delegated to the MSP 3415D, if the automatic switching feature (AUTO\_FM, section 6.4.2.) is applied.

**Table 6–12:** DCO registers for the MSP 3415D; reset status: DCO\_HI/LO = "0000"

DCO1_LO 0093 <sub>hex</sub> , DCO1_HI 009B <sub>hex</sub> ; DCO2_LO 00A3 <sub>hex</sub> , DCO2_HI 00AB <sub>hex</sub>					
Frq. MHz	DCO_HI/hex	DCO_LO/hex	Frq. MHz	DCO_HI/hex	DCO_LO/hex
4.5	03E8	000			
5.04	0460	0000	5.76	0500	0000
5.5	04C6	038E	5.85	0514	0000
5.58	04D8	0000	5.94	0528	0000
5.7421875	04FC	00AA			
6.0	0535	0555	6.6	05BA	0AAA
6.2	0561	0C71	6.65	05C5	0C71
6.5	05A4	071C	6.8	05E7	01C7
6.552	05B0	0000			
7.02	0618	0000	7.2	0640	0000
7.38	0668	0000	7.56	0690	0000

**6.6.1. Autodetect of Terrestrial TV-Audio Standards**

By means of autodetect, the MSP 3415D offers a simple and fast (<0.5 s) facility to detect the actual TV-audio standard. The algorithm checks for the FM-mono and NICAM carriers of all common TV-Sound Standards. The following notes must be considered when applying the autodetect feature:

1. Since there is no way to distinguish between AM and FM-carrier, a carrier detected at 6.5 MHz is interpreted as an AM-carrier. If video detection results in SECAM-East, the MSPD result "9" of autodetect must be reinterpreted as "Bhex" in case of CAD\_BITS[0] = 1, or as "4" or "5" by using the demodulator short programming

mode. A simple decision can be made between the two D/K FM-stereo standards by setting D/K1 and D/K2 using the short programming mode and checking the identification of both versions (see Table 6–13).

2. During active autodetect, no I<sup>2</sup>C-transfers besides reading the autodetect result are recommended. Results exceeding 07FFhex indicate an active autodetect.

3. The results are to be understood as static information, i.e. no evaluation of FM or NICAM identification concerning the dynamic mode (stereo, bilingual, or mono) are done.

4. Before switching to autodetect, the audio processing part should be muted. Do not forget to demute after having received the result.

**Table 6–13:** Result of Autodetection

Result of Autodetect 007E hex			
Code (Data) hex	Detected TV-Sound Standard Note: After detection the detected standard is set automatically according to Table 6–3.		
>07FF	autodetect still active		
0000	no TV Sound Standard was detected; select sound standard manually		
0002	M Dual-FM, even if only FM1 is available		
0003	B/G Dual-FM, even if only FM1 is available		
0008	B/G-FM-NICAM, only if NICAM is available		
0009	L_AM-NICAM, whenever a 6.5 MHz carrier is detected, even if NICAM is not available. If also D/K might be possible a decision has to be made according to the video-mode:		
	Video = SECAM_L → no more activities necessary	Video = SECAM_EAST	
		CAD_BITS[0] = 0	CAD_BITS[0] = 1
		To be set by means of the short programming mode:	
	D/K1 or D/K2 see section 6.6.1.	D/K-NICAM (standard 000Bhex)	
000A	I-FM-NICAM, even if NICAM is not available		
<p><b>Note:</b> Similar as for the Demodulator Short-Programming the Autodetection does not affect most of the parameters of the DSP section (Audio Baseband Processing): The following exceptions are to be considered:</p> <ul style="list-style-type: none"> <li>– identification mode: Autodetection resets and sets the detected mode</li> <li>– Prescale FM/AM &amp; FM matrix and Deemphasis FM are <b>undefined</b> after Autodetection</li> </ul>			

**6.6.2. C\_AD\_BITS**

NICAM operation mode control bits and A[2:0] of the additional data bits.

Format:

C_AD_BITS 0023 <sub>hex</sub>									MSB	LSB
11	...	7	6	5	4	3	2	1	0	
Auto_FM	...	A[2]	A[1]	A[0]	C4	C3	C2	C1	S	

**Important:** “S” = Bit[0] indicates correct NICAM-synchronization (S=1). If S = 0, the MSP 3415D has not yet synchronized correctly to frame and sequence, or has lost synchronization. The remaining read registers are therefore not valid. The MSP 3415D mutes the NICAM output automatically and tries to synchronize again as long as MODE\_REG[6] is set.

The operation mode is coded by C4-C1 as shown in Table 6–14.

**Table 6–14:** NICAM operation modes as defined by the EBU NICAM 728 specification

C4	C3	C2	C1	Operation Mode
0	0	0	0	Stereo sound (NICAMA/B), independent mono sound (FM1)
0	0	0	1	Two independent mono signals (NICAMA, FM1)
0	0	1	0	Three independent mono channels (NICAMA, NICAMB, FM1)
0	0	1	1	Data transmission only; no audio
1	0	0	0	Stereo sound (NICAMA/B), FM1 carries same channel
1	0	0	1	One mono signal (NICAMA). FM1 carries same channel as NICAMA
1	0	1	0	Two independent mono channels (NICAMA, NICAMB). FM1 carries same channel as NICAMA
1	0	1	1	Data transmission only; no audio
x	1	x	x	Unimplemented sound coding option (not yet defined by EBU NICAM 728 specification)

AUTO\_FM: monitor bit for the AUTO\_FM Status:  
 0: NICAM source is NICAM  
 1: NICAM source is FM

**6.6.3. ADD\_BITS [10:3] 0038<sub>hex</sub>**

Contains the remaining 8 of the 11 additional data bits. The additional data bits are not yet defined by the NICAM 728 system.

Format:

ADD_BITS 0038 <sub>hex</sub>								MSB	LSB
7	6	5	4	3	2	1	0		
A[10]	A[9]	A[8]	A[7]	A[6]	A[5]	A[4]	A[3]		

**6.6.4. CIB\_BITS**

Cib bits 1 and 2 (see NICAM 728 specifications)

Format:

CIB_BITS 003E <sub>hex</sub>							MSB	LSB
7	6	5	4	3	2	1	0	
x	x	x	x	x	x	CIB1	CIB2	

**6.6.5. ERROR\_RATE 0057<sub>hex</sub>**

Average error rate of the NICAM reception in a time interval of 182 ms, which should be close to 0.. The initial and maximum value of ERROR\_RATE is 2047. This value is also active, if the NICAM bit of MODE\_REG is not set. Since the value is achieved by filtering, a certain transition time (appr. 0.5 sec) is unavoidable. Acceptable audio may have error\_rates up to a value of 700int. Individual evaluation of this value by the CCU and an appropriate threshold may define the fallback mode from NICAM to FM/AM-mono in case of poor NICAM reception.

The bit error rate per second (BER) can be calculated by means of the following formula:

$$BER = ERROR\_RATE * 7.8 * 10^{-6} /s$$

If the automatic switching feature (AUTO\_FM; section 6.4.2.) is applied, reading of ERROR\_RATE can be omitted.

**6.6.6. CONC\_CT (for compatibility with MSP 3410B)**

This register contains the actual number of bit errors of the previous 728-bit data frame. Evaluation of CONC\_CT is no longer recommended.

**6.6.7. FAWCT\_IST (for compatibility with MSP3410B)**

For compatibility with MSP 3410B this value equals 12 as long as NICAM quality is sufficient. It decreases to 0 if NICAM reception gets poor. Evaluation of FAWCT\_IST is no longer recommended.

**6.6.8. PLL\_CAPS**

It is possible to read out the actual setting of the PLL\_CAPS. In standard applications, this register is not of interest for the customer.

PLL_CAPS	021F <sub>hex</sub>	
minimum frequency	0111 1111	7F <sub>hex</sub>
nominal frequency	0101 0110 RESET	56 <sub>hex</sub>
maximum frequency	0000 0000	00 <sub>hex</sub>

**6.6.9. AGC\_GAIN**

It is possible to read out the actual setting of AGC\_GAIN in Automatic Gain Mode. In standard applications, this register is not of interest for the customer.

AGC_GAIN	021E <sub>hex</sub>	
max. amplification (20 dB)	0001 0100	14 <sub>hex</sub>
min. amplification (3 dB)	0000 0000	00 <sub>hex</sub>

**6.7. Sequences to Transmit Parameters and to Start Processing**

After having been switched on, the MSP has to be initialized by transmitting the parameters according to the LOAD\_SEQ\_1/2 of Table 6–15. The data are immediately active after transmission into the MSP. It is no longer necessary to transmit LOAD\_REG\_1/2 or LOAD\_REG\_1 as it was for MSP 3410B. Nevertheless, transmission of LOAD\_REG\_1/2 or LOAD\_REG\_1 does no harm.

For NICAM operation, the following steps listed in 'NICAM\_WAIT, \_READ and \_Check' in Table 6–15 must be taken.

For FM-stereo operation, the evaluation of the identification signal must be performed. For a positive identification check, the MSP 3415D sound channels have to be switched corresponding to the detected operation mode.

**Table 6–15:** Sequences to initialize and start the MSP 3415D

<b>LOAD_SEQ_1/2:</b> General Initialization	
<b>General Programming Mode</b>	<b>Demodulator Short Programming</b>
<p>Write into MSP 3415D:</p> <ol style="list-style-type: none"> <li>1. AD_CV</li> <li>2. FIR1</li> <li>3. FIR2</li> <li>4. MODE_REG</li> <li>5. DCO1_LO</li> <li>6. DCO1_HI</li> <li>7. DCO2_LO</li> <li>8. DCO2_HI</li> </ol>	<p>Write into MSP 3415D:</p> <p>For example: Addr: 0020hex, Data 0008hex                      Alternatively, for terrestrial reception, the autodetect feature can be applied.</p>
<b>AUDIO PROCESSING INIT</b>	
Initialization of Audio Baseband Processing section, which may be customer dependant (see section 7.).	
<b>NICAM_WAIT:</b> Automatic Start of the NICAM-Decoder if Bit[6] of MODE_REG is set to 1	
<ol style="list-style-type: none"> <li>1. Wait at least 0.25 s</li> </ol>	
<b>NICAM_CHECK:</b> Read NICAM specific information and check for presence, operation mode, and quality of NICAM signal.	
<p>Read out of MSP 3415D:</p> <ol style="list-style-type: none"> <li>1. C_AD_BITS</li> <li>2. CONC_CT or ERROR_RATE; if AUTO_FM is active, reading of CONC_CT or ERROR_RATE can be omitted.</li> </ol> <p>Evaluation of C_AD_BITS and CONC_CT or ERROR_RATE in the CCU (see section 6.6.).                      If necessary, switch the corresponding sound channels within the audio baseband processing section.</p>	
<b>FM_WAIT:</b> Automatic start of the FM-identification process if Bit[6] of MODE_REG is set to 0.	
<ol style="list-style-type: none"> <li>1. Ident Reset</li> <li>2. Wait at least 0.5 s</li> </ol>	
<b>FM_IDENT_CHECK:</b> Read FM specific information and check for presence, operation mode, and quality of dual carrier FM.	
<p>Read out of MSP 3415D:</p> <ol style="list-style-type: none"> <li>1. Stereo detection register (DSP register 0018<sub>hex</sub>, high part)</li> </ol> <p>Evaluation of the stereo detection register (see section 7.5.1.)                      If necessary, switch the corresponding sound channels within the audio baseband processing section</p>	
<b>LOAD_SEQ_1:</b> Reinitialization of Channel 1 without affecting Channel 2	
<p>Write into MSP 3415D:</p> <ol style="list-style-type: none"> <li>1. FIR1 (6 · 8 bit)</li> <li>2. MODE_REG (12 bit)</li> <li>3. DCO1_LO (12 bit)</li> <li>4. DCO1_HI</li> </ol>	<p>Write into MSP 3415D:</p> <p>For example: Addr: 0020hex, Data: 0003hex</p>
<b>PAUSE:</b> Duration of “Pause” determines the repetition rate of the NICAM or the FM_IDENT-check.	
<b>Note:</b> If downwards compatibility to the MSP3410B is required, the MSP 3415D may be programmed according to the MSP 3410B data sheet.	



**6.8. Software Proposals for Multistandard TV-Sets**

To familiarize the reader with the programming scheme of the MSP 3415D demodulator part, three examples in the shape of flow diagrams are shown in the following sections.

**6.8.1. Multistandard Including System B/G with NICAM/FM-Mono only**

Fig. 6–1 shows a flow diagram for the CCU software, applied for the MSP 3415D in a TV set, which facilitates NICAM and FM-mono sound. For the instructions, please refer to Table 6–15.

If the program is changed, resulting in another program within the Scandinavian System B/G, no parameters of the MSP 3415D need be modified. To facilitate the check for NICAM, the CCU has only to continue at the 'NICAM\_WAIT' instruction. During the NICAM-identification process, the MSP 3415D must be switched to the FM-mono sound.

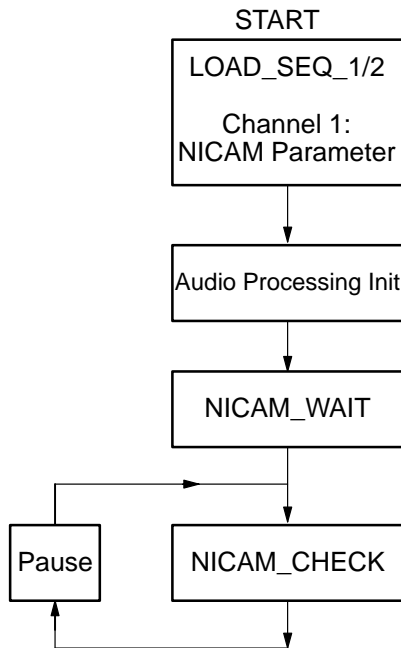

**Fig. 6–1:** CCU software flow diagram: Standard B/G/I NICAM/FM mono only

**6.8.2. Multistandard Including System I with NICAM/FM-Mono only**

This case is identical to the one above. The only difference consists in selecting the UK parameters for DCO1\_LO/HI, DCO2\_LO/HI, and FIR1.

**6.8.3. Multistandard Including System B/G with NICAM/FM-Mono and German DUAL FM**

Fig. 6–3 shows a flow diagram for the CCU software, applied for the MSP 3415D in a TV set, which facilitates all standards according to System B/G. For the instructions used in the diagram, please refer to Table 6–15.

After having switched on the TV-set and having initialized the MSP 3415D (LOAD\_SEQ\_1/2), FM-mono sound is available.

Fig. 6–3 shows that to check for any stereo or bilingual audio information in channel 1, its parameter should be loaded with NICAM and FM2 parameters, alternately (LOAD\_SEQ\_1). If successful, the MSP 3415 D must switch to the desired audio mode.

**6.8.4. Satellite Mode**

Fig. 6–2 shows the simple flow diagram to be used for the MSP 3415D in a satellite receiver. For FM-mono operation, the corresponding FM carrier should preferably be processed at the MSP-channel 2.

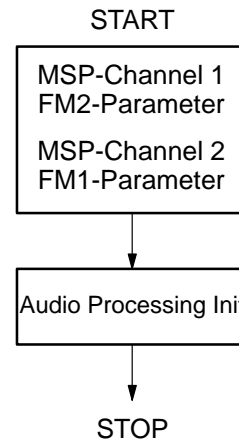

**Fig. 6–2:** CCU software flow diagram: SAT-mode

**6.8.5. Automatic Search Function for FM-Carrier Detection**

The AM demodulation ability of the MSP 3415D offers the possibility to calculate the “field strength” of the momentarily selected FM carrier, which can be read out by the CCU. In SAT receivers, this feature can be used to make automatic FM carrier search possible.

Therefore, the MSPD has to be switched to AM-mode (MODE\_REG[8]), FM-Prescale must be set to 7F<sub>hex</sub>=+127<sub>dez</sub>, and the FM DC notch must be switched off. The sound-IF frequency range must now be “scanned” in the MSPD-channel 2 by means of the programmable quadrature mixer with an appropriate incremental frequency (i.e. 10 kHz).

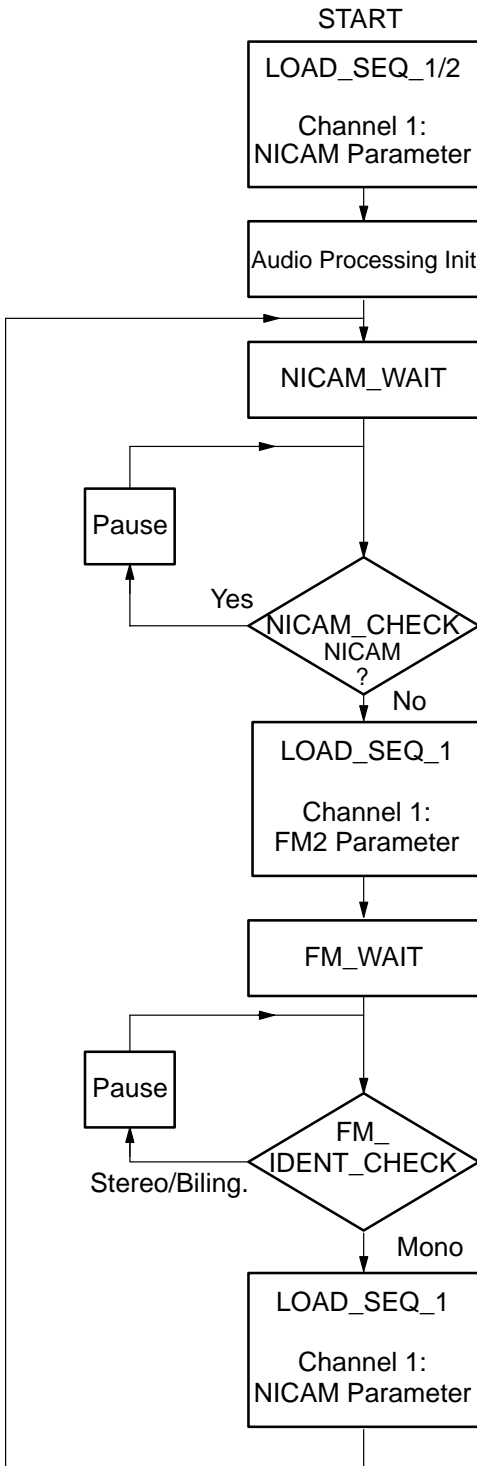

Fig. 6-3: CCU software flow diagram: Standard B/G with NICAM or FM stereo

After each incrementation, a field strength value is available at the quasi-peak detector output (quasi-peak detector source must be set to FM), which must be examined for relative maxima by the CCU. This results in either continuing search or switching the MSP 3415D back to FM demodulation mode.

During the search process, the FIR2 must be loaded with the coefficient set "AUTOSEARCH", which enables small bandwidth, resulting in appropriate field strength characteristics. The absolute field strength value (can be read out of "quasi peak detector output FM1") also gives information on whether a main FM carrier or a sub-carrier was detected, and as a practical consequence, the FM bandwidth (FIR1/2) and the deemphasis (50 µs or adaptive) can be switched automatically.

Due to the fact that a constant demodulation frequency offset of a few kHz, leads to a DC-level in the demodulated signal, further fine tuning of the found carrier can be achieved by evaluating the "DC Level Readout FM1". Therefore, the FM DC Notch must be switched on, and the demodulator part must be switched back to FM-demodulation mode.

For a detailed description of the automatic search function, please refer to the corresponding MSP 3400C Windows software.

**Note:** The automatic search is still possible by evaluating only the DC Level Readout FM1 (DC Notch On) as it is described with the MSP 3410B, but the above mentioned method is faster. If this DC Level method is applied with the MSP 3415D, it is recommended to set MODE\_REG[15] to 1 (AM-Gain= 12 dB) and to use the new Autosearch FIR2 coefficient set as given in Table 6-11.

## 7. Programming the DSP Section (Audio Baseband Processing)

### 7.1. DSP Write Registers: Table and Addresses

**Table 7–1:** DSP Write Registers; Subaddress: 12 hex; if necessary these registers are readable as well.

DSP Write Register	Address	High/Low	Adjustable Range, Operational Modes	Reset Mode
Volume loudspeaker channel	0000 <sub>hex</sub>	H	[+12 dB ... –114 dB, MUTE]	MUTE
Volume / Mode loudspeaker channel		L	1/8 dB Steps, Reduce Volume / Tone Control	00 <sub>hex</sub>
Balance loudspeaker channel [L/R]	0001 <sub>hex</sub>	H	[0..100 / 100 % and vv][–127..0 / 0 dB and vv]	100%/100%
Balance Mode loudspeaker		L	[Linear mode / logarithmic mode]	linear mode
Bass loudspeaker channel	0002 <sub>hex</sub>	H	[+12 dB ... –12 dB]	0 dB
Treble loudspeaker channel	0003 <sub>hex</sub>	H	[+12 dB ... –12 dB]	0 dB
Volume SCART1 channel	0007 <sub>hex</sub>	H	[00 <sub>hex</sub> ... 7F <sub>hex</sub> ],[+12 dB ... –114 dB, MUTE]	00 <sub>hex</sub>
Volume / Mode SCART1 channel		L	[Linear mode / logarithmic mode]	linear mode
Loudspeaker channel source	0008 <sub>hex</sub>	H	[FM/AM, NICAM, SCART]	FM/AM
Loudspeaker channel matrix		L	[SOUNDA, SOUNDB, STEREO, MONO]	SOUNDA
SCART1 channel source	000a <sub>hex</sub>	H	[FM/AM, NICAM, SCART]	FM/AM
SCART1 channel matrix		L	[SOUNDA, SOUNDB, STEREO, MONO]	SOUNDA
Quasi-peak detector source	000c <sub>hex</sub>	H	[FM/AM, NICAM, SCART]	FM/AM
Quasi-peak detector matrix		L	[SOUNDA, SOUNDB, STEREO, MONO]	SOUNDA
Prescale SCART	000d <sub>hex</sub>	H	[00 <sub>hex</sub> ... 7F <sub>hex</sub> ]	00 <sub>hex</sub>
Prescale FM/AM	000e <sub>hex</sub>	H	[00 <sub>hex</sub> ... 7F <sub>hex</sub> ]	00 <sub>hex</sub>
FM matrix		L	[NO_MAT, GSTEREO, KSTEREO]	NO_MAT
Deemphasis FM	000f <sub>hex</sub>	H	[OFF, 50 μs, 75 μs, J17]	50 μs
Adaptive Deemphasis FM		L	[OFF, WP1]	OFF
Prescale NICAM	0010 <sub>hex</sub>	H	[00 <sub>hex</sub> ... 7F <sub>hex</sub> ]	00 <sub>hex</sub>
ACB Register (SCART Switching Facilities)	0013 <sub>hex</sub>	H/L	Bits [15..0]	00 <sub>hex</sub>
Beeper	0014 <sub>hex</sub>	H/L	[00 <sub>hex</sub> ... 7F <sub>hex</sub> ]/[00 <sub>hex</sub> ... 7F <sub>hex</sub> ]	0/0
Identification Mode	0015 <sub>hex</sub>	L	[B/G, M]	B/G
FM DC Notch	0017 <sub>hex</sub>	L	[ON, OFF]	ON
Automatic Volume Correction	0029 <sub>hex</sub>	H	[off, on, decay time]	off

7.2. DSP Read Registers: Table and Addresses

Table 7–2: DSP Read Registers; Subaddress: 13 hex

DSP Read Register	Address	High/Low	Output Range
Stereo detection register	0018 <sub>hex</sub>	H	[80 <sub>hex</sub> ... 7F <sub>hex</sub> ] 8 bit two's complement
Quasi peak readout left	0019 <sub>hex</sub>	H&L	[00 <sub>hex</sub> ... 7FFF <sub>hex</sub> ] 16 bit two's complement
Quasi peak readout right	001a <sub>hex</sub>	H&L	[00 <sub>hex</sub> ... 7FFF <sub>hex</sub> ] 16 bit two's complement
DC level readout FM1/Ch2-L	001b <sub>hex</sub>	H&L	[8000 <sub>hex</sub> ... 7FFF <sub>hex</sub> ] 16 bit two's complement
DC level readout FM2/Ch1-R	001c <sub>hex</sub>	H&L	[8000 <sub>hex</sub> ... 7FFF <sub>hex</sub> ] 16 bit two's complement

7.3. DSP Write Registers: Functions and Values

Write registers are 16 bit wide, whereby the MSB is denoted bit [15]. Transmissions via I<sup>2</sup>C bus have to take place in 16-bit words. Some of the defined 16-bit words are divided into low [7:0] and high [15:8] byte, or in an other manner, thus holding two different control entities. All write registers are readable. Unused parts of the 16-bit registers must be zero. Addresses not given in this table must not be written at any time!

7.3.1. Volume Loudspeaker Channel

Volume Loudspeaker	0000 <sub>hex</sub> [15:4]
+12 dB	0111 1111 0000 7F0 <sub>hex</sub>
+11.875 dB	0111 1110 1110 7EE <sub>hex</sub>
+0.125 dB	0111 0011 0010 732 <sub>hex</sub>
0 dB	0111 0011 0000 730 <sub>hex</sub>
-0.125 dB	0111 0010 1110 72E <sub>hex</sub>
-113.875 dB	0000 0001 0010 012 <sub>hex</sub>
-114 dB	0000 0001 0000 010 <sub>hex</sub>
Mute	0000 0000 0000 000 <sub>hex</sub> RESET
Fast Mute	1111 1111 1110 FFE <sub>hex</sub>

The highest given positive 8-bit number (7F<sub>hex</sub>) yields in a maximum possible gain of 12 dB. Decreasing the volume register by 1 LSB decreases the volume by 1 dB. Volume settings lower than the given minimum mute the output. With large scale input signals, positive volume settings may lead to signal clipping.

The MSP 3415D loudspeaker volume function is divided up in a digital and an analog section.

With Fast Mute, volume is reduced to mute position by digital volume only. Analog volume is not changed. This reduces any audible DC plops. Going back from Fast Mute should be done to the volume step before Fast Mute was activated.

Clipping Mode Loudspeaker	0000 <sub>hex</sub> [3:0]
Reduce Volume	0000 RESET 0 <sub>hex</sub>
Reduce Tone Control	0001 1 <sub>hex</sub>
Compromise Mode	0010 2 <sub>hex</sub>

If the clipping mode is set to “Reduce Volume”, the following clipping procedure is used: To prevent severe clipping effects with bass or treble boosts, the internal volume is automatically limited to a level where, in combination with either bass or treble setting, the amplification does not exceed 12 dB.

If the clipping mode is “Reduce Tone Control”, the bass or treble value is reduced if amplification exceeds 12 dB.

If the clipping mode is “Compromise Mode”, the bass or treble value and volume are reduced half and half if amplification exceeds 12 dB.

Example:	Vol.: +6 dB	Bass: +9 dB	Treble: +5 dB
Red. Volume	3	9	5
Red. Tone Con.	6	6	5
Compromise	4.5	7.5	5

### 7.3.2. Balance Loudspeaker Channel

Positive balance settings reduce the left channel without affecting the right channel; negative settings reduce the right channel leaving the left channel unaffected. In linear mode, a step by 1 LSB decreases or increases the balance by about 0.8% (exact figure: 100/127). In logarithmic mode, a step by 1 LSB decreases or increases the balance by 1 dB.

Balance Mode Loudspeaker	0001 <sub>hex</sub>	[3:0]
linear	0000 RESET	0 <sub>hex</sub>
logarithmic	0001	1 <sub>hex</sub>

Linear Mode		
Balance Loudspeaker Channel [L/R]	0001 <sub>hex</sub>	H
Left muted, Right 100%	0111 1111	7F <sub>hex</sub>
Left 0.8%, Right 100%	0111 1110	7E <sub>hex</sub>
Left 99.2%, Right 100%	0000 0001	01 <sub>hex</sub>
Left 100%, Right 100%	0000 0000 RESET	00 <sub>hex</sub>
Left 100%, Right 99.2%	1111 1111	FF <sub>hex</sub>
Left 100%, Right 0.8%	1000 0010	82 <sub>hex</sub>
Left 100%, Right muted	1000 0001	81 <sub>hex</sub>

Logarithmic Mode		
Balance Loudspeaker Channel [L/R]	0001 <sub>hex</sub>	H
Left -127 dB, Right 0 dB	0111 1111	7F <sub>hex</sub>
Left -126 dB, Right 0 dB	0111 1110	7E <sub>hex</sub>
Left -1 dB, Right 0 dB	0000 0001	01 <sub>hex</sub>
Left 0 dB, Right 0 dB	0000 0000 RESET	00 <sub>hex</sub>
Left 0 dB, Right -1 dB	1111 1111	FF <sub>hex</sub>
Left 0 dB, Right -127 dB	1000 0001	81 <sub>hex</sub>
Left 0 dB, Right -128 dB	1000 0000	80 <sub>hex</sub>

### 7.3.3. Bass Loudspeaker Channel

Bass Loudspeaker	0002 <sub>hex</sub>	H
+20 dB	0111 1111	7F <sub>hex</sub>
+18 dB	0111 1000	78 <sub>hex</sub>
+16 dB	0111 0000	70 <sub>hex</sub>
+14 dB	0110 1000	68 <sub>hex</sub>
+12 dB	0110 0000	60 <sub>hex</sub>
+11 dB	0101 1000	58 <sub>hex</sub>
+1 dB	0000 1000	08 <sub>hex</sub>
+1/8 dB	0000 0001	01 <sub>hex</sub>
0 dB	0000 0000 RESET	00 <sub>hex</sub>
-1/8 dB	1111 1111	FF <sub>hex</sub>
-1 dB	1111 1000	F8 <sub>hex</sub>
-11 dB	1010 1000	A8 <sub>hex</sub>
-12 dB	1010 0000	A0 <sub>hex</sub>

With positive bass settings, internal overflow may occur even with overall volume less than 0 dB. This will lead to a clipped output signal. Therefore, it is not recommended to set bass to a value that, in conjunction with volume, would result in an overall positive gain.

## 7.3.4. Treble Loudspeaker Channel

Treble Loudspeaker	0003 <sub>hex</sub>	H
+15 dB	0111 1000	78 <sub>hex</sub>
+14 dB	0111 0000	70 <sub>hex</sub>
+1 dB	0000 1000	08 <sub>hex</sub>
+1/8 dB	0000 0001	01 <sub>hex</sub>
0 dB	0000 0000 RESET	00 <sub>hex</sub>
-1/8 dB	1111 1111	FF <sub>hex</sub>
-1 dB	1111 1000	F8 <sub>hex</sub>
-11 dB	1010 1000	A8 <sub>hex</sub>
-12 dB	1010 0000	A0 <sub>hex</sub>

With positive treble settings, internal overflow may occur even with overall volume less than 0 dB. This will lead to a clipped output signal. Therefore, it is not recommended to set treble to a value that, in conjunction with volume, would result in an overall positive gain.

## 7.3.5. Volume SCART1

Volume Mode SCART1	0007 <sub>hex</sub>	[3:0]
linear	0000 RESET	0 <sub>hex</sub>
logarithmic	0001	1 <sub>hex</sub>

Linear Mode		
Volume SCART1	0007 <sub>hex</sub>	H
OFF	0000 0000 RESET	00 <sub>hex</sub>
0 dB gain (digital full scale (FS) to 2 V <sub>RMS</sub> output)	0100 0000	40 <sub>hex</sub>
+6 dB gain (-6 dBFS to 2 V <sub>RMS</sub> output)	0111 1111	7F <sub>hex</sub>

Logarithmic Mode		
Volume SCART1	0007 <sub>hex</sub>	[15:4]
+12 dB	0111 1111 0000	7F0 <sub>hex</sub>
+11.875 dB	0111 1110 1110	7EE <sub>hex</sub>
+0.125 dB	0111 0011 0010	732 <sub>hex</sub>
0 dB	0111 0011 0000	730 <sub>hex</sub>
-0.125 dB	0111 0010 1110	72E <sub>hex</sub>
-113.875 dB	0000 0001 0010	012 <sub>hex</sub>
-114 dB	0000 0001 0000	010 <sub>hex</sub>
Mute	0000 0000 0000 RESET	000 <sub>hex</sub>

## 7.3.6. Channel Source Modes

Loudspeaker Source	0008 <sub>hex</sub>	H
SCART1 Source	000a <sub>hex</sub>	H
FM/AM	0000 0000 RESET	00 <sub>hex</sub>
NICAM	0000 0001	01 <sub>hex</sub>
SCART	0000 0010	02 <sub>hex</sub>

## 7.3.7. Channel Matrix Modes

Loudspeaker Matrix	0008 <sub>hex</sub>	L
SCART1 Matrix	000a <sub>hex</sub>	L
SOUNDA / LEFT / MSP-IF-CHANNEL2	0000 0000 RESET	00 <sub>hex</sub>
SOUNDB / RIGHT / MSP-IF-CHANNEL1	0001 0000	10 <sub>hex</sub>
STEREO	0010 0000	20 <sub>hex</sub>
MONO	0011 0000	30 <sub>hex</sub>

## 7.3.8. SCART Prescale

Volume Prescale SCART	000d <sub>hex</sub>	H
OFF	0000 0000 RESET	00 <sub>hex</sub>
0 dB gain (2 V <sub>RMS</sub> in- put to digital full scale)	0001 1001	19 <sub>hex</sub>
+14 dB gain (400 mV <sub>RMS</sub> input to digital full scale)	0111 1111	7F <sub>hex</sub>

**Comments for the FM/AM-Prescaling:**

For the **High Deviation Mode**, the FM prescaling values can be used in the range from 13<sub>hex</sub> to 30<sub>hex</sub>. Please consider the internal reduction of 6 dB for this mode. The FIR-bandwidth should be selected to 500 kHz.

1) Given deviations will result in internal digital full scale signals. Appropriate clipping headroom has to be set by the customer. This can be done by decreasing the listed values by a specific factor.

2) In the mentioned SIF-level range, the AM-output level remains stable and independent of the actual SIF-level. In this case, only the AM degree of audio signals above 40 Hz determines the AM-output level.

## 7.3.9. FM/AM Prescale

Volume Prescale FM (Normal FM Mode)	000e <sub>hex</sub>	H
OFF	0000 0000 RESET	00 <sub>hex</sub>
Maximum Volume (28 kHz deviation <sup>1)</sup> recommended FIR- bandwidth: 130 kHz)	0111 1111	7F <sub>hex</sub>
Deviation 50 kHz <sup>1)</sup> recommended FIR- bandwidth: 200 kHz	0100 1000	48 <sub>hex</sub>
Deviation 75 kHz <sup>1)</sup> recommended FIR- bandwidth: 200 or 280 kHz	0011 0000	30 <sub>hex</sub>
Deviation 150 kHz <sup>1)</sup> recommended FIR- bandwidth: 380 kHz	0001 1000	18 <sub>hex</sub>
Maximum deviation 192 kHz <sup>1)</sup> recommended FIR- bandwidth: 380 kHz	0001 0011	13 <sub>hex</sub>
Prescale for adaptive deemphasis WP1 recommended FIR- bandwidth: 130 kHz	0001 0000	10 <sub>hex</sub>
Volume Prescale FM (High Dev.- Mode)	000e <sub>hex</sub>	H
OFF	0000 0000 RESET	00 <sub>hex</sub>
Deviation 150 kHz <sup>1)</sup> recommended FIR- bandwidth: 380 kHz	0011 0000	30 <sub>hex</sub>
Maximum deviation 384 kHz <sup>1)</sup> recommended FIR- bandwidth: 500 kHz	0001 0100	14 <sub>hex</sub>
Volume Prescale AM	000e <sub>hex</sub>	H
OFF	0000 0000 RESET	00 <sub>hex</sub>
SIF input level:  0.1 V <sub>pp</sub> – 0.8 V <sub>pp</sub> <sup>1)</sup> <sup>2)</sup> 0.8 V <sub>pp</sub> – 1.4 V <sub>pp</sub> <sup>1)</sup>	0111 1100	7C <sub>hex</sub> <7C <sub>hex</sub>
<b>Note:</b> For AM the bit MODE_REG[15] must be 1		

7.3.10. FM Matrix Modes

FM Matrix	000e <sub>hex</sub>	L
NO MATRIX	0000 0000 RESET	00 <sub>hex</sub>
GSTEREO	0000 0001	01 <sub>hex</sub>
KSTEREO	0000 0010	02 <sub>hex</sub>

NO\_MATRIX is used for terrestrial mono or satellite stereo sound. GSTEREO dematrixes [(L+R)/2, R] to [L, R] and is used for German dual carrier stereo system (Standard B/G). KSTEREO dematrixes [(L+R)/2, (L-R)/2] to [L, R] and is used for the Korean dual carrier stereo system (Standard M).

7.3.11. FM Fixed Deemphasis

Deemphasis FM	000f <sub>hex</sub>	H
50 μs	0000 0000 RESET	00 <sub>hex</sub>
75 μs	0000 0001	01 <sub>hex</sub>
J17	0000 0100	04 <sub>hex</sub>
OFF	0011 1111	3F <sub>hex</sub>

7.3.12. FM Adaptive Deemphasis

FM Adaptive Deemphasis WP1	000f <sub>hex</sub>	L
OFF	0000 0000 RESET	00 <sub>hex</sub>
WP1	0011 1111	3F <sub>hex</sub>

7.3.13. NICAM Prescale

Volume Prescale NICAM	0010 <sub>hex</sub>	H
OFF	0000 0000 RESET	00 <sub>hex</sub>
0 dB gain	0010 0000	20 <sub>hex</sub>
+12 dB gain	0111 1111	7F <sub>hex</sub>

7.3.14. NICAM Deemphasis

A J17 Deemphasis is always applied to the NICAM signal. It is not switchable.

7.3.15. ACB Register (see Fig. 4-3); [15:14] = 0 !

Definition of SCART-Switching Facilities

ACB Register	0013 <sub>hex</sub>	[13:0]
<b>DSP IN</b> Selection of Source: * SC1_IN_L/R MONO_IN SC2_IN_L/R Mute	xx xx00 xx00 0000 xx xx01 xx00 0000 xx xx10 xx00 0000 xx xx11 xx10 0000	
<b>SC1_OUT_L/R</b> Selection of Source: SC2_IN_L/R MONO_IN SCART1 via D/A SC1_IN_L/R Mute	xx 01xx x0x0 0000 xx 10xx x0x0 0000 xx 11xx x0x0 0000 xx 01xx x1x0 0000 xx 11xx x1x0 0000	
* = RESET position, which becomes active at the time of the first write transmission on the control bus to the audio processing part (DSP). By writing to the ACB register first, the RESET state can be redefined. <b>Note:</b> After RESET, SC1_OUT_L/R is undefined!		

**Note:** If “MONO\_IN” is selected at the DSP\_IN selection, the channel matrix mode of the corresponding output channel(s) must be set to “sound A”.

7.3.16. Beeper

Beeper Volume	0014 <sub>hex</sub>	H
OFF	0000 0000 RESET	00 <sub>hex</sub>
Maximum Volume (full digital scale FDS)	0111 1111	7F <sub>hex</sub>
Beeper Frequency	0014 <sub>hex</sub>	L
16 Hz (lowest)	0000 0001	01 <sub>hex</sub>
1 kHz	0100 0000	40 <sub>hex</sub>
4 kHz (highest)	1111 1111	FF <sub>hex</sub>

A squarewave beeper can be added to the loudspeaker channel. The addition point is just before volume adjustment.



### 7.3.17. Identification Mode

Identification Mode	0015 <sub>hex</sub>	L
Standard B/G (German Stereo)	0000 0000 RESET	00 <sub>hex</sub>
Standard M (Korean Stereo)	0000 0001	01 <sub>hex</sub>
Reset of Ident-Filter	0011 1111	3F <sub>hex</sub>

To shorten the response time of the identification algorithm after a program change between two FM-stereo capable programs, the reset of the ident-filter can be applied.

Sequence:

1. Program change
2. Reset ident-filter
3. Set identification mode back to standard B/G
4. Wait approx. 0.5 sec.
5. Read stereo detection register

### 7.3.18. FM DC Notch

The DC compensation filter (FM DC Notch) for FM input can be switched off. This is used to speed up the automatic search function (see section 6.8.5.). In normal FM-mode, the FM DC Notch should be switched on.

FM DC Notch	0017 <sub>hex</sub>	L
ON	0000 0000 Reset	00 <sub>hex</sub>
OFF	0011 1111	3F <sub>hex</sub>

### 7.3.19. Automatic Volume Correction (AVC)

AVC	on/off	0029 <sub>hex</sub>	[15:12]
AVC	off and Reset of int. variables	0000 RESET	0 <sub>hex</sub>
AVC	on	1000	8 <sub>hex</sub>
AVC	Decay Time	0029 <sub>hex</sub>	[11:8]
8 sec	(long)	1000	8 <sub>hex</sub>
4 sec	(middle)	0100	4 <sub>hex</sub>
2 sec	(short)	0010	2 <sub>hex</sub>
20 ms	(very short)	0001	1 <sub>hex</sub>

Different sound sources (e.g. Terrestrial channels, SAT channels or SCART) fairly often do not have the same volume level. Advertisement during movies, as well, usually has a different (higher) volume level than the movie itself. The Automatic Volume Correction (AVC) solves this problem and equalizes the volume levels.

The absolute value of the incoming signal is fed into a filter with 16 ms attack time and selectable decay time. The decay time must be adjusted as shown in the table above. This attack/decay filter block works similar to a peak hold function. The volume correction value with its quasi continuous step width is calculated using the attack/decay filter output.

The Automatic Volume Correction works with an internal reference level of  $-18$  dBFS. This means, input signals with a volume level of  $-18$  dBFS will not be affected by the AVC. If the input signals vary in a range of  $-24$  dB to  $0$  dB, the AVC compensates this.

Example: A static input signal of 1 kHz on Scart has an output level as shown in the table below.

Scart Input 0 dbr = 2 Vrms	Volume Correc- tion	Main Output 0 dBr = 1.4 Vrms
0 dBr	$-18$ dB	$-18$ dBr
$-6$ dBr	$-12$ dB	$-18$ dBr
$-12$ dBr	$-6$ dB	$-18$ dBr
$-18$ dBr	$-0$ dB	$-18$ dBr
$-24$ dBr	$+ 6$ dB	$-18$ dBr
$-30$ dBr	$+ 6$ dB	$-24$ dBr
Loudspeaker Volume = 73h = 0 dBFS Scart Prescale = 20h i.e. 2.0 Vrms = 0 dBFS		

To reset the internal variables, the AVC should be switched off and on during any channel or source change. For standard applications, the recommended decay time is 4 sec.

**Note:** AVC should not be used in any Dolby Prologic mode, except PANORAMA, where no other than the loudspeaker output is active.

**7.4. Exclusions for the Audio Baseband Features**

In general, all functions can be switched independently of the others. One exception exists:

1. NICAM cannot be processed simultaneously with the FM2 channel.
2. FM adaptive deemphasis WPI cannot be processed simultaneously with the FM-identification.

**7.5. DSP Read Registers: Functions and Values**

All readable registers are 16-bit wide. Transmissions via I<sup>2</sup>C bus have to take place in 16-bit words. Single data entries are 8 bit. Some of the defined 16-bit words are divided into low and high byte, thus holding two different control entities.

These registers are not writeable.

**7.5.1. Stereo Detection Register**

<b>Stereo Detection Register</b>	<b>0018<sub>hex</sub></b>	<b>H</b>
Stereo Mode	Reading (two's complement)	
MONO	near zero	
STEREO	positive value (ideal reception: 7F <sub>hex</sub> )	
BILINGUAL	negative value (ideal reception: 80 <sub>hex</sub> )	

**7.5.2. Quasi-Peak Detector**

<b>Quasi-Peak Readout Left</b>	<b>0019<sub>hex</sub></b>	<b>H+L</b>
<b>Quasi-Peak Readout Right</b>	<b>001a<sub>hex</sub></b>	<b>H+L</b>
Quasi peak readout	[0 <sub>hex</sub> ... 7FFF <sub>hex</sub> ] values are 16 bit two's complement	

The quasi peak readout register can be used to read out the quasi peak level of any input source, in order to adjust all inputs to the same normal listening level. The refresh rate is 32 kHz. The feature is based on a filter time constant:

attack-time: 1.3 ms  
decay-time: 37 ms

**7.5.3. DC Level Register**

<b>DC Level Readout FM1 (MSP-Ch2)</b>	<b>001b<sub>hex</sub></b>	<b>H+L</b>
<b>DC Level Readout FM2 (MSP-Ch1)</b>	<b>001c<sub>hex</sub></b>	<b>H+L</b>
DC Level	[8000 <sub>hex</sub> ... 7FFF <sub>hex</sub> ] values are 16 bit two's complement	

The DC level register measures the DC component of the incoming FM signals (FM1 and FM2). This can be used for seek functions in satellite receivers and for IF FM frequencies fine tuning. A too low demodulation frequency (DCO) results in a positive DC-Level and vice versa. For further processing, the DC content of the demodulated FM signals is suppressed. The time constant  $\tau$ , defining the transition time of the DC Level Register, is approximately 28 ms.

8. Specifications

8.1. Outline Dimensions

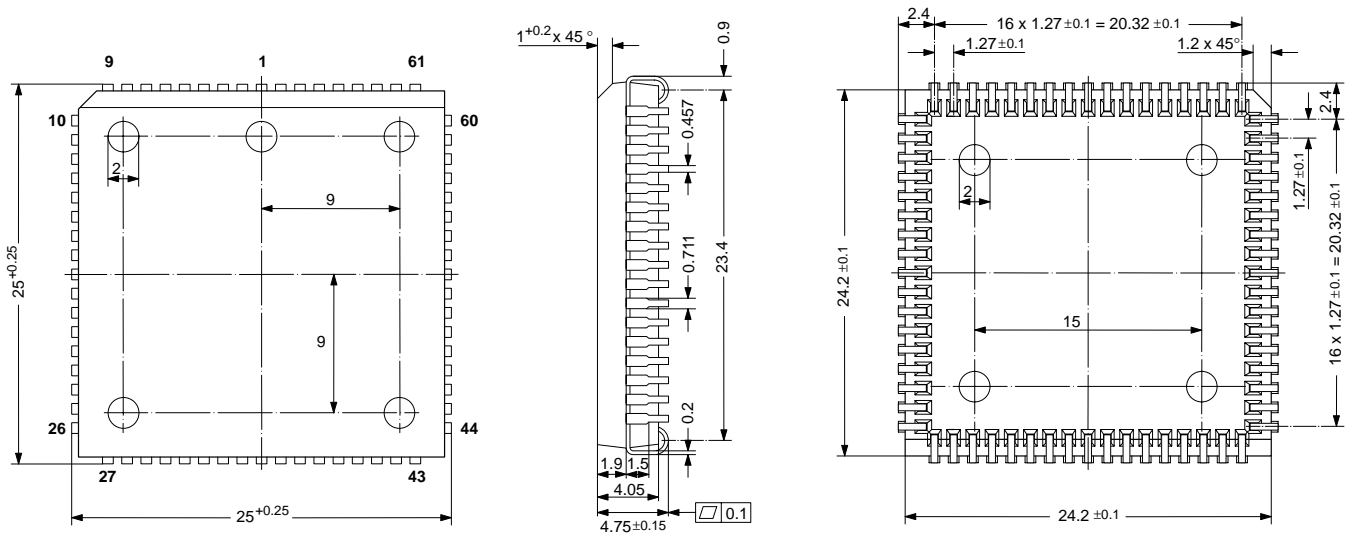

**Fig. 8-1:**  
 68-Pin Plastic Leaded Chip Carrier Package  
**(PLCC68)**  
 Weight approximately 4.8 g  
 Dimensions in mm

SPGS7004-3/4E

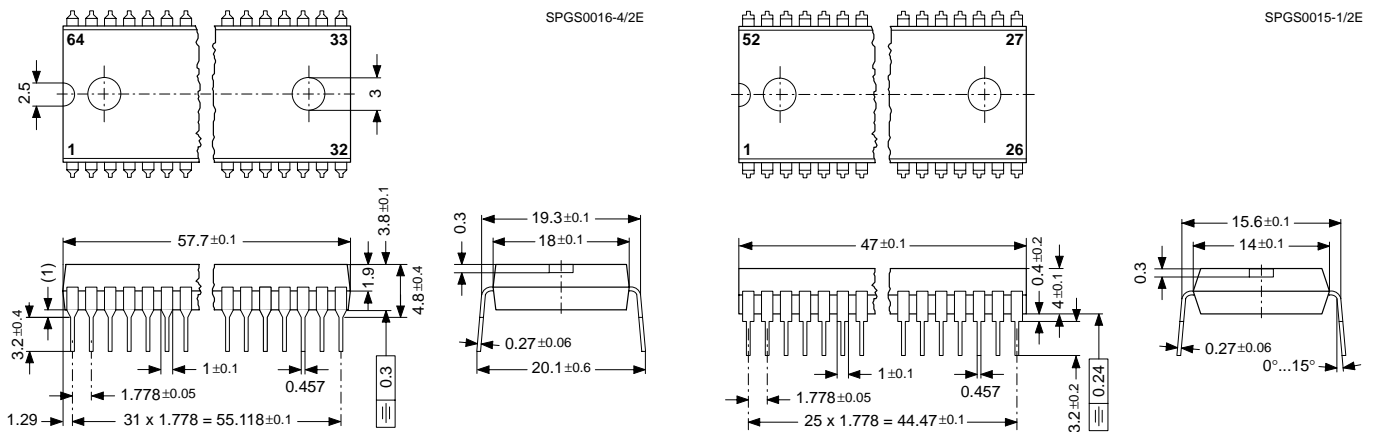
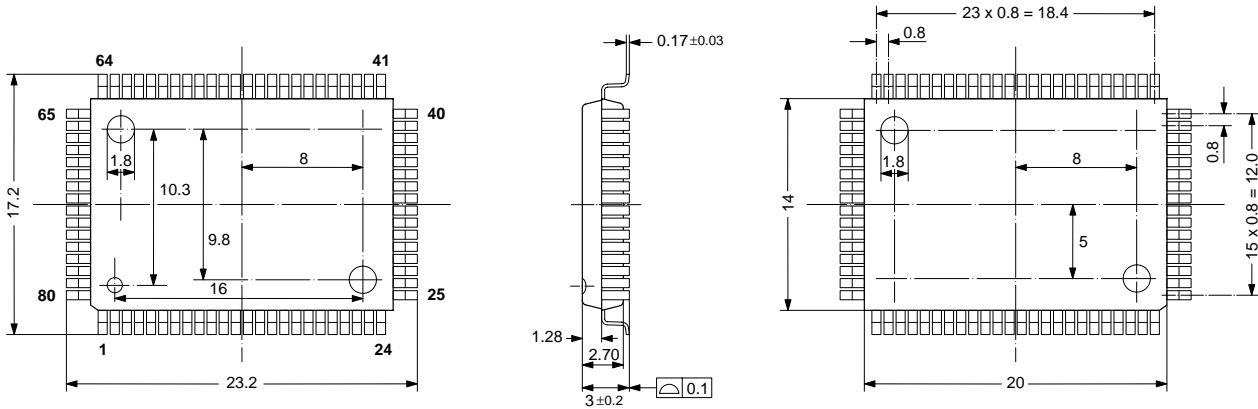

**Fig. 8-2:**  
 64-Pin Plastic Shrink Dual In Line Package  
**(PSDIP64)**  
 Weight approximately 9.0 g  
 Dimensions in mm

**Fig. 8-3:**  
 52-Pin Plastic Shrink Dual In Line Package  
**(PSDIP52)**  
 Weight approximately 5.5 g  
 Dimensions in mm

SPGS0016-4/2E

SPGS0015-1/2E



SPGS0025-1/1E

**Fig. 8-4:**  
 80-Pin Plastic Quad Flat Pack Package  
**(PQFP80)**  
 Weight approximately 1.61 g  
 Dimensions in mm

**8.2. Pin Connections and Short Descriptions**

NC = not connected; leave vacant  
 LV = if not used, leave vacant  
 DVSS: if not used, connect to DVSS

X = obligatory; connect as described in circuit diagram  
 AHVSS: connect to AHVSS

Pin No.				Pin Name	Type	Connection (if not used)	Short Description
PLCC 68-pin	PSDIP 64-pin	PSDIP 52-pin	PQFP 80-pin				
1	16	14	9	TP	OUT	LV	Test pin
2	—	—	—	NC		LV	Not connected
3	15	13	8	TP	OUT	LV	Test pin
4	14	12	7	NC		LV	Not connected
5	13	11	6	TP	OUT	LV	Test pin
6	12	10	5	TP	IN/OUT	LV	Test pin
7	11	9	4	TP	IN/OUT	LV	Test pin
8	10	8	3	I <sup>2</sup> C_DA	IN/OUT	X	I <sup>2</sup> C data
9	9	7	2	I <sup>2</sup> C_CL	IN/OUT	X	I <sup>2</sup> C clock
10	8	—	1	NC		LV	Not connected
11	7	6	80	STANDBYQ	IN	X	Standby (low-active)
12	6	5	79	ADR_SEL	IN	X	I <sup>2</sup> C Bus address select
13	5	4	78	TP	OUT	LV	Test pin
14	4	3	77	TP	OUT	LV	Test pin
15	3	—	76	NC		LV	Not connected
16	2	—	75	NC		LV	Not connected

PLCC 68-pin	Pin No.			Pin Name	Type	Connection (if not used)	Short Description
	PSDIP 64-pin	PSDIP 52-pin	PQFP 80-pin				
17	–	–	–	NC		LV	Not connected
18	1	2	74	TP	OUT	LV	Test pin
19	64	1	73	NC		LV	Test pin
20	63	52	72	XTAL_OUT	OUT	X	Crystal oscillator
21	62	51	71	XTAL_IN	IN	X	Crystal oscillator
22	61	50	70	TESTEN	IN	X	Test pin
23	60	49	69	NC		LV	Not connected
24	59	48	68	ANA_IN–	IN	LV	IF common
25	58	47	67	ANA_IN1+	IN	LV	IF input 1
26	57	46	66	AVSUP		X	Analog power supply +5 V
–	–	–	65	AVSUP		X	Analog power supply +5 V
–	–	–	64	NC		LV	Not connected
–	–	–	63	NC		LV	Not connected
27	56	45	62	AVSS		X	Analog ground
–	–	–	61	AVSS		X	Analog ground
28	55	44	60	MONO_IN	IN	LV	Mono input
–	–	–	59	NC		LV	Not connected
29	54	43	58	VREFTOP		X	Reference voltage IF A/D converter
30	53	42	57	SC1_IN_R	IN	LV	Scart input 1 in, right
31	52	41	56	SC1_IN_L	IN	LV	Scart input 1 in, left
32	51	–	55	ASG1		AHVSS	Analog Shield Ground 1
33	50	40	54	SC2_IN_R	IN	LV	Scart input 2 in, right
34	49	39	53	SC2_IN_L	IN	LV	Scart input 2 in, left
35	48	–	52	ASG2		AHVSS	Analog Shield Ground 2
36	47	38	51	NC		LV	Not connected
37	46	37	50	NC		LV	Not connected
38	45	–	49	NC			Not connected
39	44	–	48	NC		LV	Not connected
40	43	–	47	NC		LV	Not connected

PLCC 68-pin	Pin No.			Pin Name	Type	Connection (if not used)	Short Description
	PSDIP 64-pin	PSDIP 52-pin	PQFP 80-pin				
41	–	–	46	NC		LV or AHVSS	Not connected
42	42	36	45	AGNDC		X	Analog reference voltage high voltage part
43	41	35	44	AHVSS		X	Analog ground
–	–	–	43	AHVSS		X	Analog ground
–	–	–	42	NC		LV	Not connected
–	–	–	41	NC		LV	Not connected
44	40	34	40	CAPL_M		X	Volume capacitor MAIN
45	39	33	39	AHVSUP		X	Analog power supply 8.0 V
46	38	32	38	NC		LV	Not connected
47	37	31	37	SC1_OUT_L	OUT	LV	Scart output 1, left
48	36	30	36	SC1_OUT_R	OUT	LV	Scart output 1, right
49	35	29	35	VREF1		X	Reference ground 1 high voltage part
50	34	28	34	NC		LV	Not connected
51	33	27	33	NC		LV	Not connected
52	–	–	32	NC		LV	Not connected
53	32	–	31	NC		LV	Not connected
54	31	26	30	TP	OUT	LV	Test Pin
55	30	–	29	NC		LV	Not connected
56	29	25	28	DACM_L	OUT	LV	Loudspeaker out, left
57	28	24	27	DACM_R	OUT	LV	Loudspeaker out, right
58	27	23	26	VREF2		X	Reference ground 2 high voltage part
59	26	22	25	NC		LV	Not connected
60	25	21	24	NC		LV	Not connected
–	–	–	23	NC		LV	Not connected
–	–	–	22	NC		LV	Not connected
61	24	20	21	RESETQ	IN	X	Power-on-reset
62	23	–	20	NC		LV	Not connected
63	22	–	19	NC		LV	Not connected
64	21	19	18	NC		LV	Not connected

Pin No.				Pin Name	Type	Connection (if not used)	Short Description
PLCC 68-pin	PSDIP 64-pin	PSDIP 52-pin	PQFP 80-pin				
65	20	18	17	NC		LV	Not connected
66	19	17	16	DVSS		X	Digital ground
–	–	–	15	DVSS		X	Digital ground
–	–	–	14	DVSS		X	Digital ground
67	18	16	13	DVSUP		X	Digital power supply +5 V
–	–	–	12	DVSUP		X	Digital power supply +5 V
–	–	–	11	DVSUP		X	Digital power supply +5 V
68	17	15	10	TP	OUT	LV	Test pin

8.3. Pin Configurations

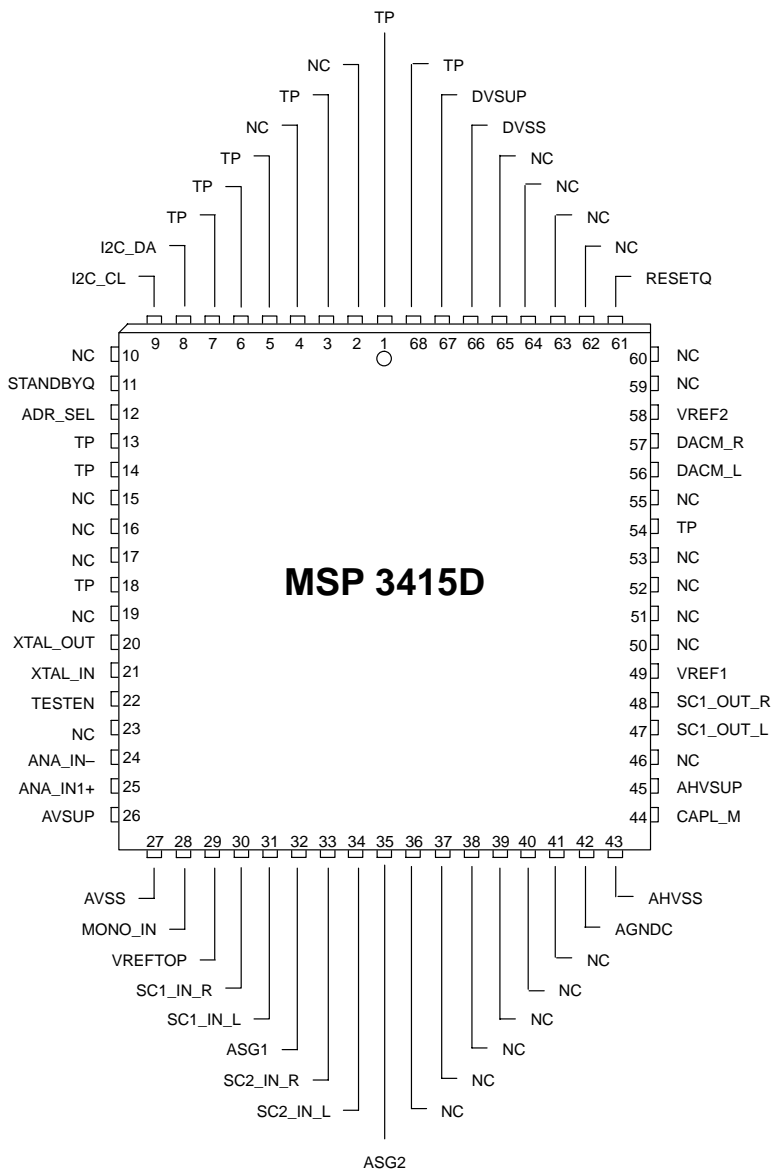

Fig. 8-5: 68-pin PLCC package



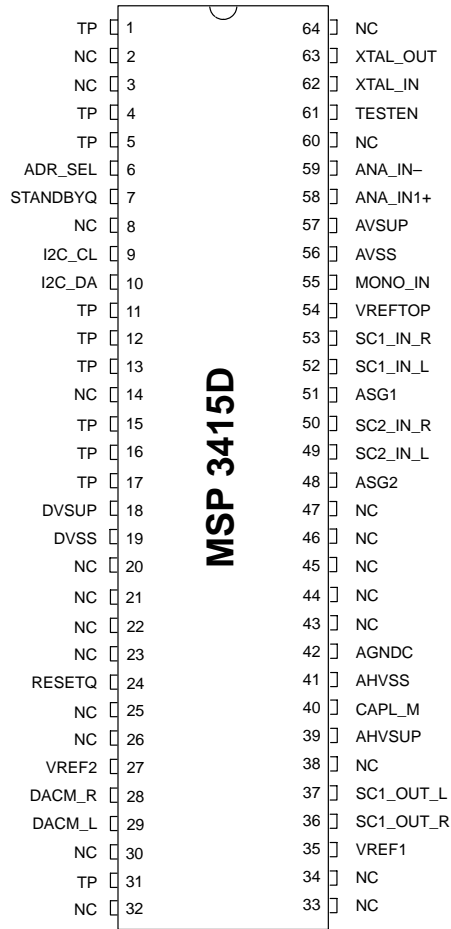

Fig. 8–6: 64-pin PSDIP package

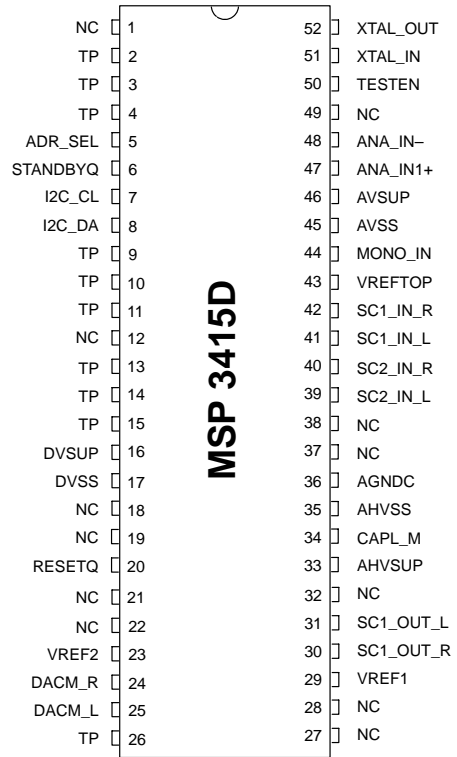

Fig. 8–7: 52-pin PSDIP package

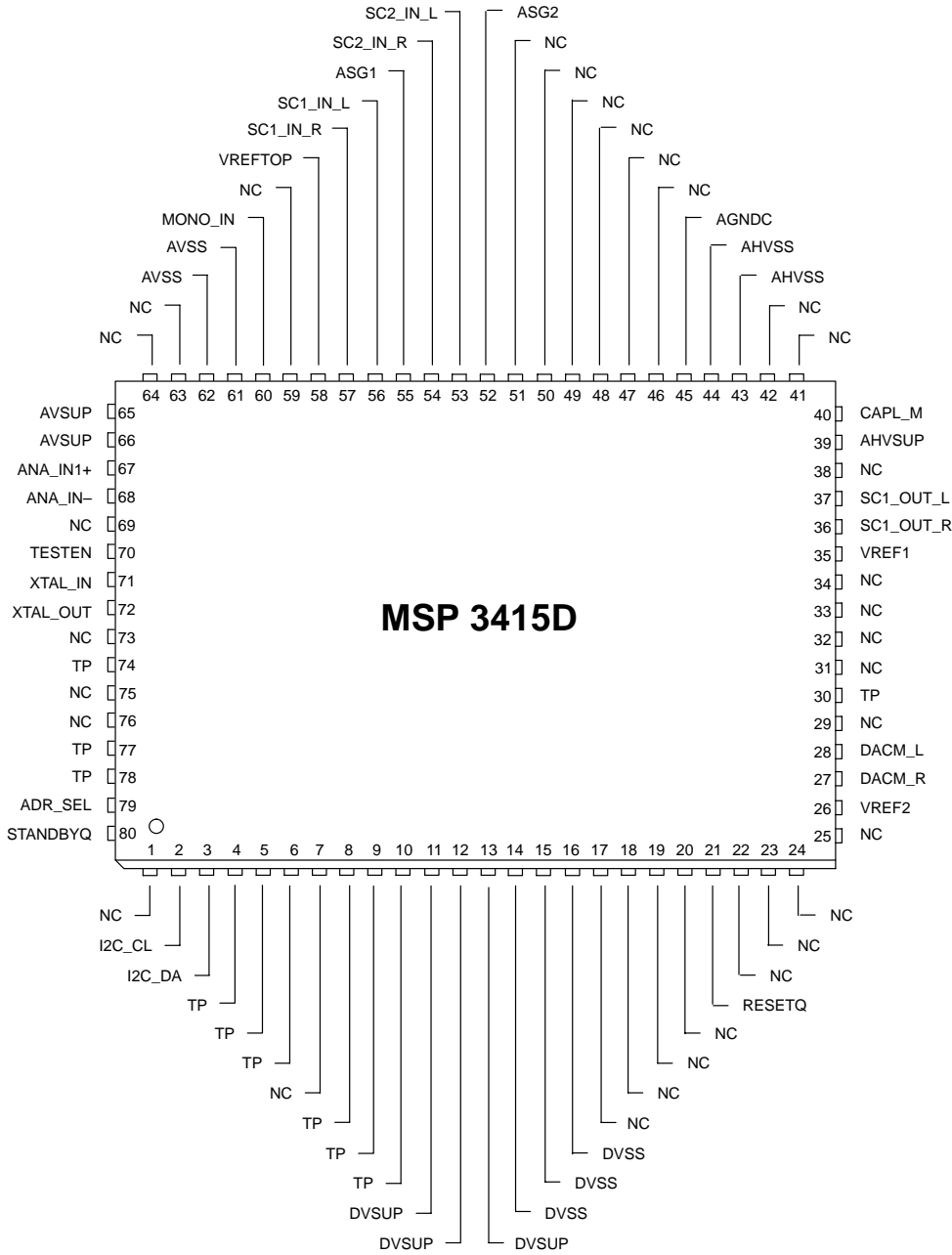

Fig. 8-8: 80-pin PQFP package

8.4. Pin Circuits (pin numbers refer to PLCC68 package)

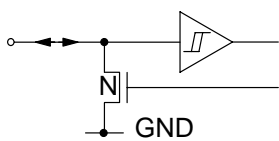

Fig. 8-9: Input/Output Pins 8 and 9 (I<sup>2</sup>C\_DA, I<sup>2</sup>C\_CL)

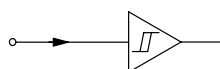
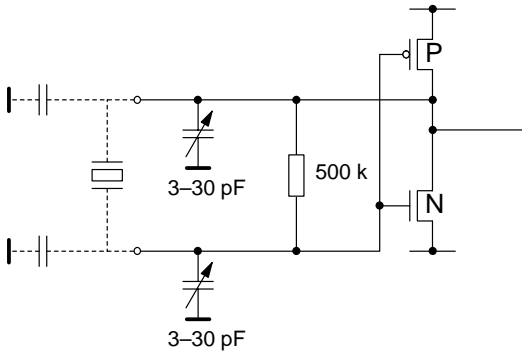
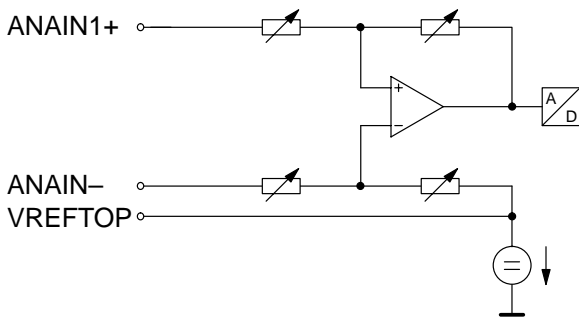

Fig. 8-10: Input Pins 4, 11, 12, 61, (STANDBYQ, ADDR\_SEL, RESETQ, TESTEN)



**Fig. 8-11:** Output/Input Pins 20 and 21 (XTALIN/OUT)



**Fig. 8-12:** Input Pins 24, 25 and 29 (ANA\_IN-, ANA\_IN1+, VREFTOP)

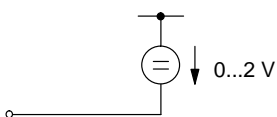

**Fig. 8-13:** Capacitor Pin 44 (CAPL\_M)

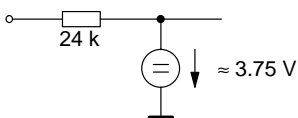

**Fig. 8-14:** Input Pin 28 (MONO\_IN)

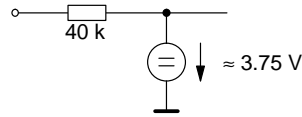

**Fig. 8-15:** Input Pins 30, 31, 33, 34 (SC1-2\_IN\_L/R)

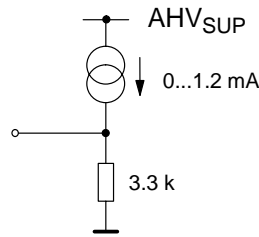

**Fig. 8-16:** Output Pins 56, 57 (DACM\_L/R)

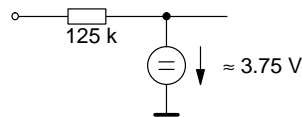

**Fig. 8-17:** Pin 42 (AGNDC)

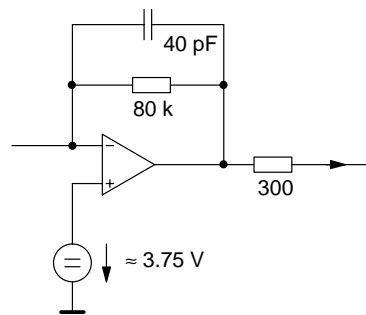

**Fig. 8-18:** Output Pins 47, 48 (SC1\_OUT\_L/R)

## 8.5. Electrical Characteristics

### 8.5.1. Absolute Maximum Ratings

Symbol	Parameter	Pin Name	Min.	Max.	Unit
$T_A$	Ambient Operating Temperature	–	0	70	°C
$T_S$	Storage Temperature	–	–40	125	°C
$V_{SUP1}$	First Supply Voltage	AHVSUP	–0.3	9.0	V
$V_{SUP2}$	Second Supply Voltage	DVSUP	–0.3	6.0	V
$V_{SUP3}$	Third Supply Voltage	AVSUP	–0.3	6.0	V
$dV_{SUP23}$	Voltage between AVSUP and DVSUP	AVSUP, DVSUP	–0.5	0.5	V
$P_{TOT}$	Chip Power Dissipation PLCC68 without Heat Spreader PSDIP64 without Heat Spreader PSDIP52 without Heat Spreader	AHVSUP, DVSUP, AVSUP		1200 1300 1200	mW
$V_{Idig}$	Input Voltage, all Digital Inputs		–0.3	$V_{SUP2}+0.3$	V
$I_{Idig}$	Input Current, all Digital Pins	–	–20	+20	mA <sup>1)</sup>
$V_{Iana}$	Input Voltage, all Analog Inputs	SCn_IN_s, <sup>2)</sup> MONO_IN	–0.3	$V_{SUP1}+0.3$	V
$I_{Iana}$	Input Current, all Analog Inputs	SCn_IN_s, <sup>2)</sup> MONO_IN	–5	+5	mA <sup>1)</sup>
$I_{Oana}$	Output Current, all SCART Outputs	SC1_OUT_s	3), 4)	3), 4)	
$I_{Oana}$	Output Current, all Analog Outputs except SCART Outputs	DACM_s <sup>2)</sup>	3)	3)	
$I_{Cana}$	Output Current, other pins connected to capacitors	CAPL_M AGND_C	3)	3)	

1) positive value means current flowing into the circuit

2) “n” means “1” or “2”, “s” means “L” or “R”

3) The Analog Outputs are short circuit proof with respect to First Supply Voltage and Ground.

4) Total chip power dissipation must not exceed absolute maximum rating.

Stresses beyond those listed in the “Absolute Maximum Ratings” may cause permanent damage to the device. This is a stress rating only. Functional operation of the device at these or any other conditions beyond those indicated in the “Recommended Operating Conditions/Characteristics” of this specification is not implied. Exposure to absolute maximum ratings conditions for extended periods may affect device reliability.

**8.5.2. Recommended Operating Conditions**(at  $T_A = 0$  to  $70$  °C)

Symbol	Parameter	Pin Name	Min.	Typ.	Max.	Unit
$V_{SUP1}$	First Supply Voltage	AHVSUP	7.6	8.0	8.4	V
$V_{SUP2}$	Second Supply Voltage	DVSUP	4.75	5.0	5.25	V
$V_{SUP3}$	Third Supply Voltage	AVSUP	4.75	5.0	5.25	V
$V_{REIL}$	RESET Input High-Low and Low-High Transition Voltage	RESETQ	0.45		0.8	$V_{SUP2}$
$t_{REIL}$	RESET Low Time after DVSUP Stable and Oscillator Startup		5			$\mu$ s
$V_{DIGIL}$	Digital Input Low Voltage	STANDBYQ, ADR_SEL, TESTEN			0.2	$V_{SUP2}$
$V_{DIGIH}$	Digital Input High Voltage		0.8			$V_{SUP2}$
$t_{STBYQ1}$	STANDBYQ Setup Time before Turn-off of Second Supply Voltage	STANDBYQ, DVSUP	1			$\mu$ s
<b>I<sup>2</sup>C-Bus Recommendations</b>						
$V_{IMIL}$	I <sup>2</sup> C-BUS Input Low Voltage	I <sup>2</sup> C_CL, I <sup>2</sup> C_DA			0.3	$V_{SUP2}$
$V_{IMIH}$	I <sup>2</sup> C-BUS Input High Voltage		0.6			$V_{SUP2}$
$f_{IM}$	I <sup>2</sup> C-BUS Frequency	I <sup>2</sup> C_CL			1.0	MHz
$t_{I2C1}$	I <sup>2</sup> C START Condition Setup Time	I <sup>2</sup> C_CL, I <sup>2</sup> C_DA	120			ns
$t_{I2C2}$	I <sup>2</sup> C STOP Condition Setup Time		120			ns
$t_{I2C3}$	I <sup>2</sup> C-Clock Low Pulse Time	I <sup>2</sup> C_CL	500			ns
$t_{I2C4}$	I <sup>2</sup> C-Clock High Pulse Time		500			ns
$t_{I2C5}$	I <sup>2</sup> C-Data Setup Time Before Rising Edge of Clock	I <sup>2</sup> C_CL, I <sup>2</sup> C_DA	55			ns
$t_{I2C6}$	I <sup>2</sup> C-Data Hold Time after Falling Edge of Clock		55			ns

Symbol	Parameter	Pin Name	Min.	Typ.	Max.	Unit
Crystal Recommendations for <b>FM / NICAM</b> Applications						
$f_P$	Parallel Resonance Frequency at 12 pF Load Capacitance			18.432		MHz
$f_{TOL}$	Accuracy of Adjustment		-30		+30	ppm
$D_{TEM}$	Frequency Variation vs Temp.		-30		+30	ppm
$R_R$	Series Resistance			8	25	$\Omega$
$C_0$	Shunt (Parallel) Capacitance			6.2	7.0	pF
$C_1$	Motional (Dynamic) Capacitance		15			fF
Load Capacitance Recommendations for <b>FM / NICAM</b> Applications						
$C_L$	External Load Capacitance <sup>1)</sup>	XTAL_IN, XTAL_OUT	PSDIP	1.5		pF
			PLCC	3.3		pF
$f_{CL}$	Required Open Loop Clock Frequency ( $T_{amb} = 25\text{ }^\circ\text{C}$ )		18.4305		18.4335	MHz
Crystal Recommendations for FM Application						
$f_P$	Parallel Resonance Frequency at 12 pF Load Capacitance			18.432		MHz
$f_{TOL}$	Accuracy of Adjustment		-100		+100	ppm
$D_{TEM}$	Frequency Variation versus Temperature		-50		+50	ppm
$R_R$	Series Resistance			8	25	$\Omega$
$C_0$	Shunt (Parallel) Capacitance			6.2	7.0	pF
Load Capacitance Recommendations for FM Application						
$C_L$	External Load Capacitance <sup>1)</sup>	XTAL_IN, XTAL_OUT	PSDIP	1.5		pF
			PLCC	3.3		pF
Amplitude Recommendation for Operation with External Clock Input ( $C_{load}$ after reset = 22 pF)						
$V_{XCA}$	External Clock Amplitude	XTAL_IN	0.7			$V_{pp}$
Analog Input and Output Recommendations						
$C_{AGNDC}$	AGNDC-Filter-Capacitor	AGNDC	-20%	3.3		$\mu\text{F}$
	Ceramic Capacitor in Parallel		-20%	100		nF
<sup>1)</sup> External capacitors at each crystal pin to ground are required. They are necessary to tune the open-loop frequency of the internal PLL and to stabilize the frequency in closed-loop operation. The higher the capacitors, the lower the clock frequency results. The nominal free running frequency should match 18.432 MHz as closely as possible. Due to different layouts of customer PCBs, the matching capacitor size should be defined in the application. The suggested values (1.5 pF/3.3 pF) are figures based on experience with various PCB layouts.						

Symbol	Parameter	Pin Name	Min.	Typ.	Max.	Unit
C <sub>inSC</sub>	DC-Decoupling Capacitor in front of SCART Inputs	SCn_IN_s <sup>1)</sup>	-20%	330	+20%	nF
V <sub>inSC</sub>	SCART Input Level				2.0	V <sub>RMS</sub>
V <sub>inMONO</sub>	Input Level, Mono Input	MONO_IN			2.0	V <sub>RMS</sub>
R <sub>LSC</sub>	SCART Load Resistance	SC1_OUT_s	10			kΩ
C <sub>LSC</sub>	SCART Load Capacitance				6.0	nF
C <sub>VMA</sub>	Main Volume Capacitor	CAPL_M		10		μF
C <sub>FMA</sub>	Main Filter Capacitor	DACM_s <sup>1)</sup>	-10%	1	+10%	nF
Recommendations for Analog Sound IF Input Signal						
C <sub>VREFTOP</sub>	VREFTOP-Filter-Capacitor	VREFTOP	-20%	10		μF
	Ceramic Capacitor in Parallel		-20%	100		nF
F <sub>IF_FM</sub>	Analog Input Frequency Range	ANA_IN1+, ANA_IN-	0		9	MHz
V <sub>IF_FM</sub>	Analog Input Range FM/NICAM		0.1	0.8	3	V <sub>pp</sub>
V <sub>IF_AM</sub>	Analog Input Range AM/NICAM		0.1	0.45	0.8	V <sub>pp</sub>
R <sub>FMNI</sub>	Ratio: NICAM Carrier/FM Carrier (unmodulated carriers) BG: I:		-20	-7	0	dB
			-23	-10	0	dB
R <sub>AMNI</sub>	Ratio: NICAM Carrier/AM Carrier (unmodulated carriers)		-25	-11	0	dB dB
R <sub>FM</sub>	Ratio: FM-Main/FM-Sub Satellite			7		dB
R <sub>FM1/FM2</sub>	Ratio: FM1/FM2 German FM-System			7		dB
R <sub>FC</sub>	Ratio: Main FM Carrier/ Color Carrier		15	-	-	dB
R <sub>FV</sub>	Ratio: Main FM Carrier/ Luma Components		15	-	-	dB
PR <sub>IF</sub>	Passband Ripple		-	-	±2	dB
SUP <sub>HF</sub>	Suppression of Spectrum Above 9.0 MHz		15		-	dB
FM <sub>MAX</sub>	Maximum FM-Deviation (apprx.) normal mode high deviation mode					
					±192 ±360	kHz
1) "n" means "1" or "2", "s" means "L" or "R"						

## 8.5.3. Characteristics

at  $T_A = 0$  to  $70$  °C,  $f_{\text{CLOCK}} = 18.432$  MHz,  $V_{\text{SUP1}} = 7.6$  to  $8.4$  V,  $V_{\text{SUP2}} = 4.75$  to  $5.25$  V for min./max. values  
 at  $T_A = 60$  °C,  $f_{\text{CLOCK}} = 18.432$  MHz,  $V_{\text{SUP1}} = 8$  V,  $V_{\text{SUP2}} = 5$  V for typical values,  $T_J$  = Junction Temperature  
 MAIN (M) = Loudspeaker Channel, AUX (A) = Headphone Channel

Symbol	Parameter	Pin Name	Min.	Typ.	Max.	Unit	Test Conditions
$f_{\text{CLOCK}}$	Clock Input Frequency	XTAL_IN		18.432		MHz	
$D_{\text{CLOCK}}$	Clock High to Low Ratio		45		55	%	
$t_{\text{JITTER}}$	Clock Jitter (Verification not provided in Production test)				50	ps	
$V_{\text{xtalDC}}$	DC-Voltage Oscillator			2.5		V	
$t_{\text{Startup}}$	Oscillator Startup Time at VDD Slew-rate of 1 V/1 $\mu$ s	XTAL_IN, XTAL_OUT		0.4	2	ms	
$I_{\text{SUP1A}}$	First Supply Current (active) Analog Volume for Main and Aux at 0dB Analog Volume for Main and Aux at -30dB	AHVSUP	9.6 6.3	17.1 11.2	24.6 16.1	mA mA	
$I_{\text{SUP2A}}$	Second Supply Current (active)	DVSUP	86	95	102	mA	
$I_{\text{SUP3A}}$	Third Supply Current (active)	AVSUP	15	25	35	mA	
$I_{\text{SUP1S}}$	First Supply Current (standby mode) at $T_J = 27$ °C	AHVSUP	3.5	5.6	7.7	mA	STANDBYQ = low
$V_{\text{IMOL}}$	I <sup>2</sup> C-Data Output Low Voltage	I <sup>2</sup> C_DA			0.4	V	$I_{\text{IMOL}} = 3$ mA
$I_{\text{IMOH}}$	I <sup>2</sup> C-Data Output High Current				1.0	$\mu$ A	$V_{\text{IMOH}} = 5$ V
$t_{\text{IMOL1}}$	I <sup>2</sup> C-Data Output Hold Time after Falling Edge of Clock	I <sup>2</sup> C_DA, I <sup>2</sup> C_CL	15			ns	
$t_{\text{IMOL2}}$	I <sup>2</sup> C-Data Output Setup Time before Rising Edge of Clock		100			ns	$f_{\text{IM}} = 1$ MHz
Analog Ground							
$V_{\text{AGNDC0}}$	AGNDC Open Circuit Voltage	AGNDC	3.63	3.73	3.83	V	$R_{\text{load}} \geq 10$ M $\Omega$
$R_{\text{outAGN}}$	AGNDC Output Resistance		70	125	180	k $\Omega$	$3$ V $\leq V_{\text{AGNDC}} \leq 4$ V
Analog Input Resistance							
$R_{\text{inSC}}$	SCART Input Resistance from $T_A = 0$ to $70$ °C	SCn_IN_s <sup>1)</sup>	25	40	58	k $\Omega$	$f_{\text{signal}} = 1$ kHz, $I = 0.05$ mA
1) "n" means "1", or "2"; "s" means "L" or "R"							
$R_{\text{inMONO}}$	MONO Input Resistance from $T_A = 0$ to $70$ °C	MONO_IN	15	24	35	k $\Omega$	$f_{\text{signal}} = 1$ kHz, $I = 0.1$ mA
Audio Analog-to-Digital-Converter							
$V_{\text{AICL}}$	Effective Analog Input Clipping Level for Analog-to-Digital-Conversion	SCn_IN_s, <sup>1)</sup> MONO_IN	2.00		2.25	$V_{\text{RMS}}$	$f_{\text{signal}} = 1$ kHz
1) "n" means "1", or "2"; "s" means "L" or "R"							



Symbol	Parameter	Pin Name	Min.	Typ.	Max.	Unit	Test Conditions
SCART Outputs							
R <sub>outSC</sub>	SCART Output Resistance at T <sub>j</sub> = 27 °C from T <sub>A</sub> = 0 to 70 °C	SC1_OUT_s	200 200	330	460 500	Ω Ω	f <sub>signal</sub> = 1 kHz, I = 0.1 mA
dV <sub>OUTSC</sub>	Deviation of DC-Level at SCART Output from AGND Voltage		-70		+70	mV	
A <sub>SCtoSC</sub>	Gain from Analog Input to SCART Output	SCn_IN_s <sup>1)</sup> MONO_IN → SC1_OUT_s	-1.0		+0.5	dB	f <sub>signal</sub> = 1 kHz
f <sub>rSCtoSC</sub>	Frequency Response from Analog Input to SCART Output bandwidth: 0 to 20000 Hz		-0.5		+0.5	dB	with resp. to 1 kHz
V <sub>outSC</sub>	Effective Signal Level at SCART- Output during full-scale digital in- put signal from DSP	SC1_OUT_s	1.8	1.9	2.0	V <sub>RMS</sub>	f <sub>signal</sub> = 1 kHz
Main Outputs							
R <sub>outMA</sub>	Main Output Resistance at T <sub>j</sub> = 27 °C from T <sub>A</sub> = 0 to 70 °C	DACM_s <sup>1)</sup>	2.1 2.1	3.3	4.6 5.0	kΩ kΩ	f <sub>signal</sub> = 1 kHz, I = 0.1 mA
V <sub>outDCMA</sub>	DC-Level at Main-Output for Analog Volume at 0 dB for Analog Volume at -30 dB		1.8	2.04 61	2.28	V mV	
V <sub>outMA</sub>	Effective Signal Level at Main-Out- put during full-scale digital input signal from DSP for Analog Vol- ume at 0 dB		1.23	1.37	1.51	V <sub>RMS</sub>	f <sub>signal</sub> = 1 kHz
Analog Performance							
SNR	Signal-to-Noise Ratio						
	from Analog Input to DSP	MONO_IN, SCn_IN_s <sup>1)</sup>	85	88		dB	Input Level = -20 dB with resp. to V <sub>AICL</sub> , f <sub>sig</sub> =1 kHz, equally weighted 20 Hz ... 16 kHz <sup>2)</sup>
	from Analog Input to SCART Output	MONO_IN, SCn_IN_s <sup>1)</sup> → SC1_OUT_s	93	96		dB	Input Level = -20 dB, f <sub>sig</sub> = 1 kHz, equally weighted 20 Hz ... 20 kHz
	from DSP to SCART Output	SC1_OUT_s	85	88		dB	Input Level = -20 dB, f <sub>sig</sub> = 1 kHz, equally weighted 20 Hz ... 15 kHz <sup>3)</sup>
	from DSP to Main-Output for Analog Volume at 0 dB for Analog Volume at -30 dB	DACM_s <sup>1)</sup>	85 78	88 83		dB dB	Input Level = -20 dB, f <sub>sig</sub> = 1 kHz, equally weighted 20 Hz ... 15 kHz <sup>3)</sup>
1) "n" means "1" or "2"; "s" means "L", "R" 2) DSP measured at I <sup>2</sup> S-Output 3) DSP Input at I <sup>2</sup> S-Input							

Symbol	Parameter	Pin Name	Min.	Typ.	Max.	Unit	Test Conditions	
THD	Total Harmonic Distortion							
	from Analog Input to DSP	MONO_IN, SCn_IN_s <sup>1)</sup>		0.01	0.03	%	Input Level = -3 dBr with resp. to V <sub>AICL</sub> , f <sub>sig</sub> = 1 kHz, equally weighted 20 Hz ... 16 kHz <sup>2)</sup>	
	from Analog Input to SCART Output	MONO_IN, SCn_IN_s → SC1_OUT_s		0.01	0.03	%	Input Level = -3 dBr, f <sub>sig</sub> = 1 kHz, equally weighted 20 Hz ... 20 kHz	
	from DSP to SCART Output	SC1_OUT_s		0.01	0.03	%	Input Level = -3 dBr, f <sub>sig</sub> = 1 kHz, equally weighted 20 Hz ... 16 kHz <sup>3)</sup>	
	from DSP to Main Output	DACM_s <sup>1)</sup>		0.01	0.03	%	Input Level = -3 dBr, f <sub>sig</sub> = 1 kHz, equally weighted 20 Hz ... 16 kHz <sup>3)</sup>	
XTALK	Crosstalk attenuation - PLCC68 - PSDIP64						Input Level = -3 dB, f <sub>sig</sub> = 1 kHz, unused analog inputs connected to ground by Z < 1 kΩ	
	between left and right channel within SCART Input/Output pair (L→R, R→L)						equally weighted 20 Hz ... 20 kHz	
	SCn_IN → SC1_OUT	PLCC68 PSDIP64	80 80			dB dB		
	SC1_IN or SC2_IN → DSP <sup>1)</sup>	PLCC68 PSDIP64	80 80			dB dB	2)	
	SC3_IN → DSP <sup>1)</sup>	PLCC68 PSDIP64	80 80			dB dB		
	DSP → SC1_OUT	PLCC68 PSDIP64	80 80			dB dB	3)	
	between left and right channel within Main or AUX Output pair							equally weighted 20 Hz ... 16 kHz
	DSP → DACM	PLCC68 PSDIP64	80 75			dB dB	3)	
	between SCART Input/Output pairs <sup>1)</sup>							(equally weighted 20 Hz ... 20 kHz) same signal source on left and right disturbing channel, effect on each observed output channel
	D = disturbing program O = observed program							
D: MONO/SCn_IN → SC1_OUT O: MONO/SCn_IN → SC1_OUT <sup>1)</sup>	PLCC68 PSDIP64	100 100				dB dB		
D: MONO/SCn_IN → SC1_OUT or unsel. O: MONO/SCn_IN → DSP <sup>1)</sup>	PLCC68 PSDIP64	100 95				dB dB	2)	
D: MONO/SCn_IN → SC1_OUT <sup>1)</sup> O: DSP → SC1_OUT	PLCC68 PSDIP64	100 100				dB dB	3)	
D: MONO/SCn_IN → unselected O: DSP → SC1_OUT	PLCC68 PSDIP64	100 100				dB dB	3)	
<p>1) "n" means "1" or "2"; "s" means "L" or "R"</p> <p>2) DSP measured at I<sup>2</sup>S-Output</p> <p>3) DSP Input at I<sup>2</sup>S-Input</p>								

Symbol	Parameter	Pin Name	Min.	Typ.	Max.	Unit	Test Conditions
XTALK	Crosstalk between Main Output pairs						(equally weighted 20 Hz ... 16 kHz) <sup>3)</sup> same signal source on left and right disturbing channel, effect on each observed output channel
	DSP → DACM	PLCC68 PSDIP64	95 90			dB dB	
	Crosstalk from Main or AUX Output to SCART Output and vice versa						(equally weighted 20 Hz ... 20 kHz) same signal source on left and right disturbing channel, effect on each observed output channel
	D = disturbing program O = observed program						
	D: MONO/SCn_IN/DSP → SC1_OUT O: DSP → DACM	PLCC68 PSDIP64	85 80				dB dB
D: MONO/SCn_IN/DSP → SC1_OUT O: DSP → DACM	PLCC68 PSDIP64	90 85				dB dB	SCART output load resistance 30 kΩ
D: DSP → DACM O: MONO/SCn_IN → SC1_OUT	PLCC68 PSDIP64	100 95				dB dB	<sup>3)</sup>
D: DSP → DACM O: DSP → SC1_OUT	PLCC68 PSDIP64	100 95				dB dB	
PSRR: rejection of noise on AHVSUP at 1 kHz							
	AGNDC	AGNDC		80		dB	
	From Analog Input to DSP	MONO_IN, SCn_IN_s <sup>1)</sup>		70		dB	
	From Analog Input to SCART Output	MONO_IN, SCn_IN_s <sup>1)</sup> SC1_OUT_s		70		dB	
	From DSP to SCART Output	SC1_OUT_s		60		dB	
	From DSP to MAIN Output	DACM_s <sup>1)</sup>		80		dB	
S/N <sub>FM</sub>	FM Input to Main/AUX/SCART Output	DACp_s, SC1_OUT_s	73			dB	1 FM-carrier 5.5 MHz, 50 μs, 1 kHz, 40 kHz deviation; RMS, unweighted 0 to 15 kHz (for S/N); full input range, FM-Prescale = 46h, Vol = 0 dB → Output Level 1 V <sub>RMS</sub> at DACp_s; SPM = 3
THD <sub>FM</sub>	Total Harmonic Distortion + Noise of FM demodulated signal on Main/AUX/SCART output	DACp_s, SC1_OUT_s			0.1	%	
S/N <sub>NICAM</sub>	Signal to Noise ratio of NICAM baseband signal on Main/AUX/SCART outputs	DACp_s, SC1_OUT_s	72			dB	NICAM: -6 dB, 1 kHz, RMS unweighted 0 to 15 kHz, NIC_Presc=7Fh, Vol=9dB Output level 1 V <sub>RMS</sub> at DACp_s; SPM= 8
THD <sub>NICAM</sub>	Total Harmonic Distortion + Noise of NICAM baseband signal on Main/AUX/SCART output	DACp_s, SC1_OUT_s			0.1	%	2.12 kHz, Modulator input level = 0 dB <sub>ref</sub> SPM = 8
BER <sub>NI</sub>	NICAM: Bit Error Rate	-			1	10 <sup>-7</sup>	FM + NICAM, norm conditions
<p>1) "n" means "1" or "2"; "s" means "L" or "R"</p> <p>3) DSP Input at I<sup>2</sup>S-Input SPM : Short Programming Mode</p>							

Symbol	Parameter	Pin Name	Min.	Typ.	Max.	Unit	Test Conditions
$S/N_{AM}$	Signal to Noise ratio of AM baseband signal on Main/AUX/SCART outputs	DACp_s, SC1_OUT_s	48			dB	SIF input range: 0.1–0.8 Vpp; AM= 70%, 1 kHz, RMS unweighted (S/N); 0 to 15 kHz, FM/AM-Prescale=3Chex, Vol=0dB → Output level: 0.5 V <sub>RMS</sub> at DACp_s AM+NICAM, norm conditions; SPM= 9
$THD_{AM}$	Total Harmonic Distortion + Noise of AM demodulated signal on Main/AUX/SCART output	DACp_s, SC1_OUT_s			0.3	%	
$R_{IFIN}$	Input Impedance	ANA_IN1+, ANA_IN–	1.5 10.5	2 14.1	2.5 17.6	kΩ kΩ	Gain AGC = 20 dB Gain AGC = 3 dB
$DC_{VREFTOP}$	DC voltage at VREFTOP	VREFTOP	2.4	2.6	2.7	V	
$DC_{ANA\_IN}$	DC voltage on IF inputs	ANA_IN1+, ANA_IN–	1.3	1.5	1.7	V	
$XTALK_{IF}$	Crosstalk attenuation	ANA_IN1+, ANA_IN–	40			dB	$f_{signal} = 1$ MHz Input Level = –2 dB
$BW_{IF}$	3 dB Bandwidth		10			MHz	
AGC	AGC Step Width			0.85		dB	
$dV_{FMOUT}$	Tolerance of output voltage of FM demodulated signal	DACM_s, SC1_OUT_s	–1.5		+1.5	dB	1 FM-carrier, 50 μs, 1 kHz 40 kHz deviation; RMS
$dV_{NICAMOUT}$	Tolerance of output voltage of NICAM baseband signal	DACM_s, SC1_OUT_s	–1.5		+1.5	dB	2.12 kHz, Modulator input level = 0 dBref
$fR_{FM}$	FM Frequency Response on Main/SCART Outputs, Bandwidth 20 to 15000 Hz	DACM_s, SC1_OUT_s	–1.0		+1.0	dB	1 FM-carrier 5.5 MHz, 50 μs, Modulator input level = –14.6 dBref; RMS
$fR_{NICAM}$	NICAM Frequency Response on Main/SCART Outputs, Bandwidth 20 to 15000 Hz	DACM_s, SC1_OUT_s	–1.0		+1.0	dB	Modulator input level = –12 dB dBref; RMS
$SEP_{FM}$	FM Channel Separation (Stereo)	DACM_s, SC1_OUT_s	50			dB	2 FM-carriers 5.5/5.74 MHz, 50 μs, 1 kHz, 40 kHz deviation; RMS
$SEP_{NICAM}$	NICAM Channel Separation (Stereo)	DACM_s, SC1_OUT_s	80			dB	
$XTALK_{FM}$	FM Crosstalk Attenuation (Dual)	DACM_s, SC1_OUT_s	80			dB	2 FM-carriers 5.5/5.74 MHz, 50 μs, 1 kHz, 40 kHz deviation; RMS
$XTALK_{NICAM}$	NICAM Crosstalk Attenuation (Dual)	DACM_s, SC1_OUT_s	80			dB	

9. Application Circuit

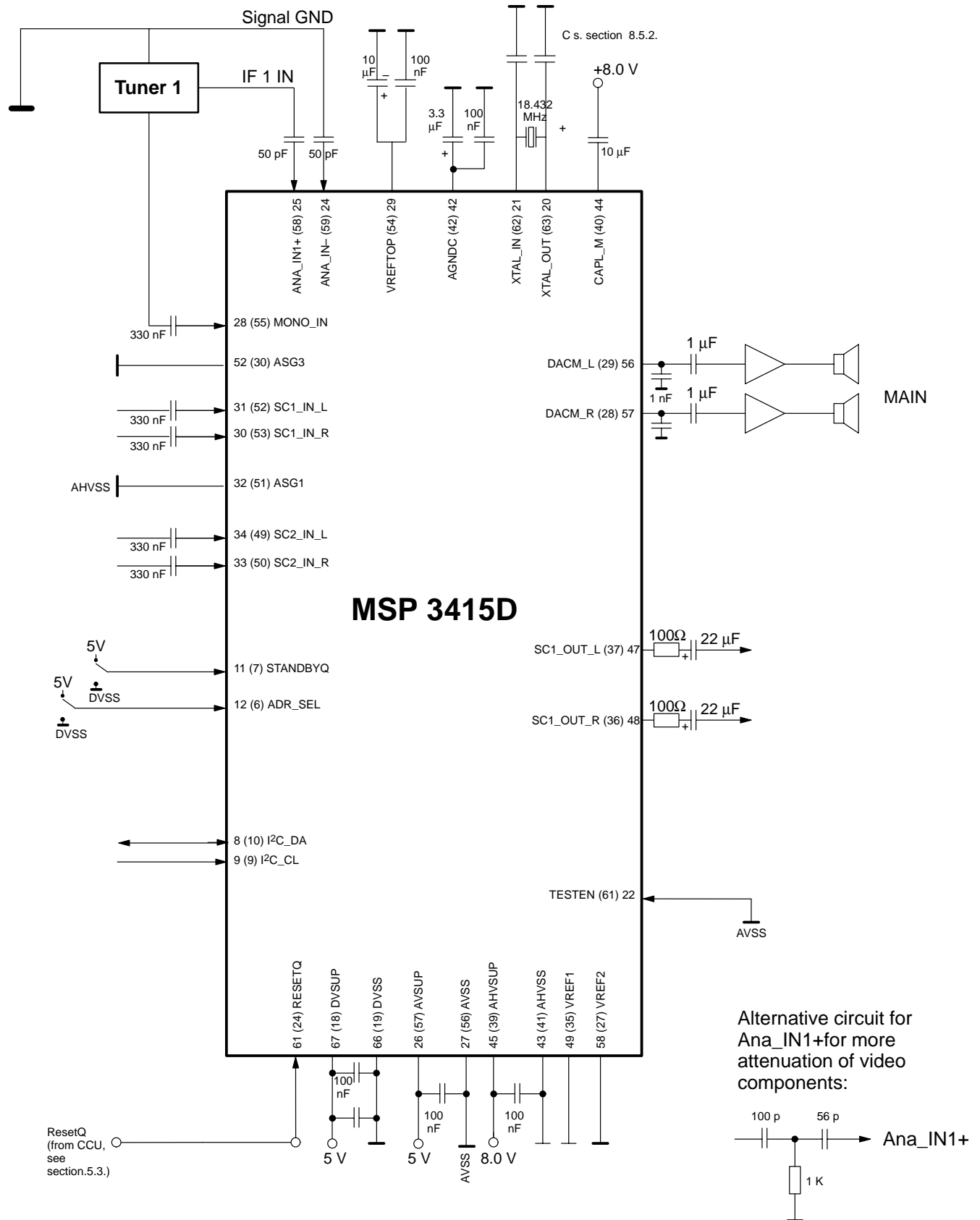

**Note:** Pin numbers refer to the PLCC68 package, numbers in brackets refer to the PSDIP64 package.





---

**10. Appendix A: MSP 3415D Version History****A1**

First hardware release

**11. Data Sheet History**

1. Preliminary Data Sheet: "MSP 3415D Multistandard Sound Processor", Sept. 25, 1997, 6251-438-1PD.  
First release of the preliminary data sheet.

2. Preliminary Data Sheet: "MSP 3415D Multistandard Sound Processor", Jan. 15, 1998, 6251-438-2PD.  
Second release of the preliminary data sheet.

Major changes:

- section 8.2.: PQFP80 pinning changed
- section 8.3. Fig. 8–8: PQFP80 pinning changed
- section 9.: pin numbers for I<sup>2</sup>C\_CL corrected

MICRONAS INTERMETALL GmbH  
Hans-Bunte-Strasse 19  
D-79108 Freiburg (Germany)  
P.O. Box 840  
D-79008 Freiburg (Germany)  
Tel. +49-761-517-0  
Fax +49-761-517-2174  
E-mail: docservice@intermetall.de  
Internet: <http://www.intermetall.de>

Printed in Germany  
Order No. 6251-438-2PD

All information and data contained in this data sheet are without any commitment, are not to be considered as an offer for conclusion of a contract nor shall they be construed as to create any liability. Any new issue of this data sheet invalidates previous issues. Product availability and delivery dates are exclusively subject to our respective order confirmation form; the same applies to orders based on development samples delivered. By this publication, MICRONAS INTERMETALL GmbH does not assume responsibility for patent infringements or other rights of third parties which may result from its use. Reprinting is generally permitted, indicating the source. However, our prior consent must be obtained in all cases.