

# MAXIM

## Complete, 12-Bit Voltage-Output DACs

MX7245/MX7248

### General Description

The MX7245/MX7248 are complete, 12-bit digital-to-analog converters (DACs) that include an internal voltage reference and a voltage-output amplifier. The MX7245/MX7248 are pin and electrically compatible with Analog Devices' AD7245/AD7248.

The MX7245/MX7248 have double-buffered logic interfaces that are easily interfaced to microprocessors ( $\mu$ Ps). Data is transferred into the Input register from a 12-bit-wide data bus (MX7245) for 16-bit  $\mu$ Ps, or in a right-justified (8+4)-bit format (MX7248) for 8- and 16-bit  $\mu$ Ps. All logic signals are level triggered and are TTL and CMOS compatible. The timing specifications ensure compatibility with common  $\mu$ Ps.

The DACs are specified and tested for both dual- and single-supply operation. Usable supplies range from single +12V to dual  $\pm 15$ V.

Internal gain-setting resistors allow three output voltage ranges: 0V to +5V and 0V to +10V can be generated using either single or dual supplies. With dual supplies, an additional output range of  $\pm 5$ V is available. The output amplifier drives 2k $\Omega$  loads to +10V.

See MAX507/MAX508 data sheet for detailed description.

### Applications

- Minimum Component Count Analog Systems
- Digital Offset and Gain Adjustment
- Industrial Control
- Arbitrary Function Generators
- Automatic Test Equipment
- Automated Calibration
- Machine and Motion Control

### Functional Diagram

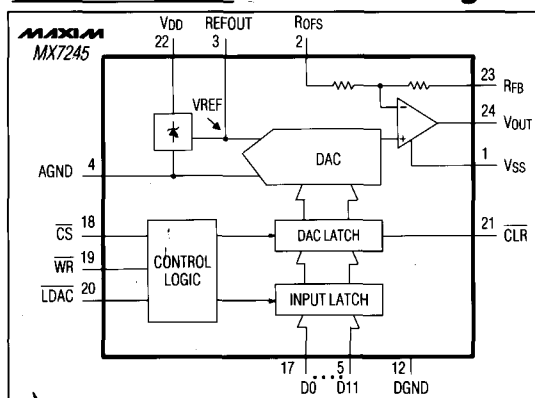

### Features

- ◆ 12-Bit Voltage Output
- ◆ Low-Noise, Buried-Zener Voltage Reference
- ◆ Fast Logic Interface (80ns WR Pulse)
- ◆ Operate from Single or Dual Supplies
- ◆ 8-/16-Bit Microprocessor-Bus Compatible
- ◆ Available in DIP and PLCC Packages
- ◆ Pin and Electrically Compatible with AD7245/AD7248

### Ordering Information

PART	TEMP. RANGE	PIN-PACKAGE
MX7245JN	0°C to +70°C	24 Plastic DIP
MX7245JP	0°C to +70°C	28 PLCC
MX7245J/D	0°C to +70°C	Dice*
MX7245AQ	-40°C to +85°C	24 CERDIP
MX7245SE	-55°C to +125°C	28 LCC**
MX7245SQ	-55°C to +125°C	24 CERDIP**
MX7248JN	0°C to +70°C	20 Plastic DIP
MX7248JP	0°C to +70°C	20 PLCC
MX7248J/D	0°C to +70°C	Dice*
MX7248AE	-40°C to +85°C	20 LCC***
MX7248AQ	-40°C to +85°C	20 CERDIP
MX7248SE	-55°C to +125°C	20 LCC**
MX7248SQ	-55°C to +125°C	20 CERDIP**

\* Contact factory for dice specifications.

\*\* Contact factory for availability and processing to MIL-STD-883.

\*\*\*Contact factory for availability.

### Pin Configurations

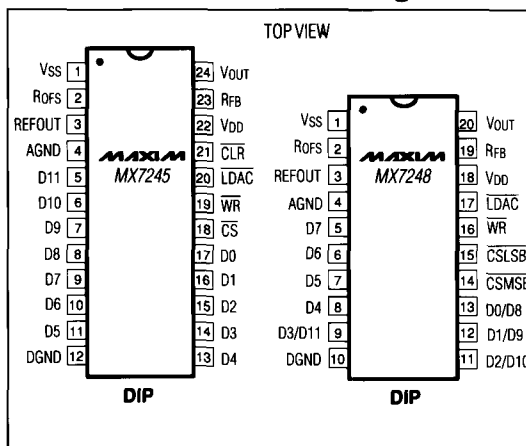

MAXIM

Maxim Integrated Products 1

Call toll free 1-800-998-8800 for free samples or literature.

## Complete, 12-Bit Voltage-Output DACs

### ABSOLUTE MAXIMUM RATINGS

VDD to AGND	-0.3V, +17V
VDD to DGND	-0.3V, +17V
VDD to VSS	-0.3V, +34V
AGND to DGND	-0.3V, VDD
Digital Input Voltage to GND	-0.3V, VDD +0.3V
VOUT to AGND (Note 1)	VSS, VDD
REFOUT to AGND (Note 1)	-0.3V, VDD +0.3V
Continuous Power Dissipation (any package)	
to +75°C	450mW
derate above +75°C by	6mW/°C

### Operating Temperature Ranges:

MX724_J_	0°C to +70°C
MX724_A_	-40°C to +85°C
MX724_S_	-55°C to +125°C
Storage Temperature Range	-65°C to +160°C
Lead Temperature (soldering, 10 sec)	+300°C

**Note 1:** The output can be shorted to either supply rail if the package power dissipation is not exceeded. Typical short-circuit current to AGND is 25mA.

Stresses beyond those listed under "Absolute Maximum Ratings" may cause permanent damage to the device. These are stress ratings only, and functional operation of the device at these or any other conditions beyond those indicated in the operational sections of the specifications is not implied. Exposure to absolute maximum rating conditions for extended periods may affect device reliability.

### ELECTRICAL CHARACTERISTICS

Single Supply (VDD = +11.4V to +15.75V, VSS = AGND = DGND = 0V, RL = 2kΩ, CL = 100pF, REFOUT unloaded, all grades, TA = TMIN to TMAX, unless otherwise noted.)

PARAMETER	SYMBOL	CONDITIONS	MIN	TYP	MAX	UNITS
<b>STATIC PERFORMANCE</b>						
Resolution	N		12			Bits
Relative Accuracy	INL				±1	LSB
Differential Nonlinearity	DNL				±1	LSB
Unipolar Offset Error	UOE	TA = +25°C			±3	LSB
		TA = TMIN to TMAX			±5	
DAC Gain Error					±2	LSB
Full-Scale Output Voltage Error	FSE	VDD = 12V or 15V	TA = +25°C	TA = TMIN to TMAX	±0.2	% of FSR
					±0.6	
ΔFull-Scale Output Voltage Error/ΔVDD		VDD = 12V or 15V ±5%	TA = +25°C	TA = TMIN to TMAX	±0.12	% of FSR
					±0.2	
Full-Scale Tempco		MX724_J_/A_			±30	ppm of FSR/°C
					MX724_S_	
ΔOffset/ΔVDD		VDD = 12V or 15V ±5%			±1	mV
<b>REFERENCE</b>						
Reference Output		VDD = 12V or 15V, TA = +25°C	4.99		5.01	V
ΔReference/ΔVDD		VDD = 12V or 15V ±5%	TA = +25°C	TA = TMIN to TMAX	2	mV/V
					6	
Reference Temperature Coefficient	TCVO	MX724_J_/A_			±30	ppm/°C
					MX724_S_	
Reference Load Sensitivity		ILOAD = 0μA to 100μA			±1	mV
<b>ANALOG OUTPUT</b>						
Output Range Resistors			15		30	kΩ
Ranges		(Note 2)			0 to 5 or 10	V
DC Output Impedance				0.5		Ω
Short-Circuit Current				25		mA

## Complete, 12-Bit Voltage-Output DACs

**MX7245/MX7248**

### ELECTRICAL CHARACTERISTICS (continued)

Single Supply ( $V_{DD} = +11.4V$  to  $+15.75V$ ,  $V_{SS} = AGND = DGND = 0V$ ,  $R_L = 2k\Omega$ ,  $C_L = 100pF$ , REFOUT unloaded, all grades,  $T_A = T_{MIN}$  to  $T_{MAX}$ , unless otherwise noted.)

PARAMETER	SYMBOL	CONDITIONS	MIN	TYP	MAX	UNITS
<b>DYNAMIC PERFORMANCE</b> (Note 3)						
Output Voltage Settling Time	$t_S$	Settling time to $\pm 1/2LSB$			5	$\mu s$
Output Voltage Slew Rate			2			V/ $\mu s$
Digital Feedthrough				10		nV-s
Digital-to-Analog Glitch Impulse	Q	Major carry transition		30		nV-s
Output Load Resistance		$V_{OUT} = 0V$ to $+10V$ (Note 2)	2			k $\Omega$
<b>POWER SUPPLIES</b>						
$V_{DD}$ Range		For specified performance	11.40		15.75	V
$I_{DD}$		Outputs unloaded			9	mA
			$T_A = +25^\circ C$		12	
			$T_A = T_{MIN}$ to $T_{MAX}$			

### ELECTRICAL CHARACTERISTICS

Dual Supply ( $V_{DD} = +11.4V$  to  $+15.75V$ ,  $V_{SS} = -11.4V$  to  $-15.75V$ ,  $DGND = AGND = 0V$ ,  $R_L = 2k\Omega$ ,  $C_L = 100pF$ , REFOUT unloaded, all grades,  $T_A = T_{MIN}$  to  $T_{MAX}$ , unless otherwise noted.)

PARAMETER	SYMBOL	CONDITIONS	MIN	TYP	MAX	UNITS
<b>STATIC PERFORMANCE</b>						
Resolution	N		12			Bits
Relative Accuracy	INL				$\pm 1$	LSB
Differential Nonlinearity	DNL				$\pm 1$	LSB
Bipolar Zero Offset Error	BZOE	$T_A = +25^\circ C$ $T_A = T_{MIN}$ to $T_{MAX}$			$\pm 3$ $\pm 5$	LSB
DAC Gain Error					$\pm 2$	LSB
Full-Scale Output Voltage Error	FSE	$V_{DD} = 15V$ or $-15V$	$T_A = +25^\circ C$		$\pm 0.2$	% of FSR
			$T_A = T_{MIN}$ to $T_{MAX}$		$\pm 0.6$	
		$V_{DD} = 12V$ or $-12V$	$T_A = +25^\circ C$		$\pm 0.2$	
			$T_A = T_{MIN}$ to $T_{MAX}$		$\pm 0.6$	
$\Delta$ Full-Scale Output Voltage Error/ $\Delta V_{DD}$		$V_{DD} = 12V$ or $15V \pm 5\%$			$\pm 0.12$ $\pm 0.2$	% of FSR
$\Delta$ Full-Scale Output Voltage Error/ $\Delta V_{SS}$		$V_{SS} = 12V$ or $15V \pm 5\%$			$\pm 1$	mV
Full-Scale Tempco		MX724_J/A_			$\pm 30$	ppm of FSR/ $^\circ C$
		MX724_S_			$\pm 40$	
$\Delta$ Offset/ $\Delta V_{DD}$		$V_{DD} = 12V$ or $15V \pm 5\%$			$\pm 1$	mV
<b>REFERENCE</b>						
Reference Output		$V_{DD} = 12V$ or $15V$ , $T_A = +25^\circ C$	4.99		5.01	V
$\Delta$ Reference/ $\Delta V_{DD}$		$V_{DD} = 12V$ or $15V \pm 5\%$	$T_A = +25^\circ C$		2	mV/V
			$T_A = T_{MIN}$ to $T_{MAX}$		6	
Reference Temperature Coefficient	TCV <sub>O</sub>	MX724_J/A_			$\pm 30$	ppm/ $^\circ C$
		MX724_S_			$\pm 40$	
Reference Load Sensitivity		$I_{LOAD} = 0\mu A$ to $100\mu A$			$\pm 1$	mV

## Complete, 12-Bit Voltage-Output DACs

### ELECTRICAL CHARACTERISTICS (continued)

Dual Supply ( $V_{DD} = +11.4V$  to  $+15.75V$ ,  $V_{SS} = -11.4V$  to  $-15.75V$ ,  $DGND = AGND = 0V$ ,  $R_L = 2k\Omega$ ,  $C_L = 100pF$ , REFOUT unloaded, all grades,  $T_A = T_{MIN}$  to  $T_{MAX}$ , unless otherwise noted.)

PARAMETER	SYMBOL	CONDITIONS	MIN	TYP	MAX	UNITS
<b>ANALOG OUTPUT</b>						
Output Range Resistors			15		30	k $\Omega$
Ranges		(Note 2)		0 to 5 or 10 -5 to 5		V
DC Output Impedance				0.5		$\Omega$
Short-Circuit Current				25		mA
<b>DYNAMIC PERFORMANCE (Note 3)</b>						
Output Voltage Settling Time	$t_s$	Settling time to $\pm 1/2LSB$			5	$\mu s$
Output Voltage Slew Rate			2			V/ $\mu s$
Digital Feedthrough				10		nV-s
Digital-to-Analog Glitch Impulse	Q	Major carry transition		30		nV-s
Output Load Resistance		$V_{OUT} = -5V$ to $+10V$	2			k $\Omega$
<b>POWER SUPPLIES</b>						
$V_{DD}$ Range		For specified performance	11.40		15.75	V
$V_{SS}$ Range		For specified performance	-11.40		-15.75	V
$I_{DD}$		Outputs unloaded			9	mA
					12	
					3	
$I_{SS}$		Outputs unloaded			5	mA
					5	

### ELECTRICAL CHARACTERISTICS

Single or Dual Supply ( $V_{DD} = +11.4V$  to  $+15.75V$ ,  $V_{SS} = 0V$  to  $-15.75V$ ,  $DGND = AGND = 0V$ ,  $R_L = 2k\Omega$ ,  $C_L = 100pF$ , REFOUT unloaded, all grades,  $T_A = T_{MIN}$  to  $T_{MAX}$ , unless otherwise noted.)

PARAMETER	SYMBOL	CONDITIONS	MIN	TYP	MAX	UNITS
<b>DIGITAL INPUTS</b>						
Input High Voltage	$V_{INH}$		2.4			V
Input Low Voltage	$V_{INL}$				0.8	V
Input Current	$I_N$	D0-D11	$T_A = +25^\circ C$		$\pm 1$	$\mu A$
			$T_A = T_{MIN}$ to $T_{MAX}$		$\pm 10$	
	$I_{INH}$	CS, WR, LDAC, CLR, CSMB, CSLSB	$T_A = +25^\circ C$		$\pm 1$	
			$T_A = T_{MIN}$ to $T_{MAX}$		$\pm 10$	
	$I_{INL}$	CS, WR, LDAC, CLR, CSMB, CSLSB	$T_A = +25^\circ C$		150	
$T_A = T_{MIN}$ to $T_{MAX}$				200		
Digital Input Capacitance	$C_{IN}$	MX7245			8	pF
		MX7248			16	

**Note 2:**  $V_{OUT}$  must be less than  $(V_{DD} - 2.5V)$ .

**Note 3:** Guaranteed at  $T_A = +25^\circ C$ , but not production tested.

## Complete, 12-Bit Voltage-Output DACs

**MX7245/MX7248**

### SWITCHING CHARACTERISTICS

( $T_A = T_{MIN} = T_{MAX}$ , unless otherwise noted.)

PARAMETER	SYMBOL	CONDITIONS	J GRADE			A GRADE			S GRADE			UNITS
			MIN	MAX	MIN	MAX	MIN	MAX	MIN	MAX		
$\overline{CS}$ Pulse Width	$t_1$	$T_A = +25^\circ\text{C}$	80	80	105						ns	
		$T_A = T_{MIN}$ to $T_{MAX}$	100	100	135							
$\overline{WR}$ Pulse Width	$t_2$	$T_A = +25^\circ\text{C}$	80	80	105						ns	
		$T_A = T_{MIN}$ to $T_{MAX}$	100	100	135							
$\overline{CS}$ to $\overline{WR}$ Setup Time	$t_3$		0	0	0					ns		
$\overline{CS}$ to $\overline{WR}$ Hold Time	$t_4$		0	0	0					ns		
Data to $\overline{WR}$ Setup Time	$t_5$ (MX7245 only)	$T_A = +25^\circ\text{C}$	100	100	155					ns		
		$T_A = T_{MIN}$ to $T_{MAX}$	110	130	250							
	$t_5$ (MX7248 only)	$T_A = +25^\circ\text{C}$	110	110	180							
		$T_A = T_{MIN}$ to $T_{MAX}$	130	130	270							
Data to $\overline{WR}$ Hold Time	$t_6$ (MX7245 only)		10	10	10				ns			
LDAC Pulse Width	$t_7$	$T_A = +25^\circ\text{C}$	80	80	90					ns		
		$T_A = T_{MIN}$ to $T_{MAX}$	100	100	120							
$\overline{CLR}$ Pulse Width	$t_8$ (MX7245 only)	$T_A = +25^\circ\text{C}$	80	80	140					ns		
		$T_A = T_{MIN}$ to $T_{MAX}$	100	100	200							

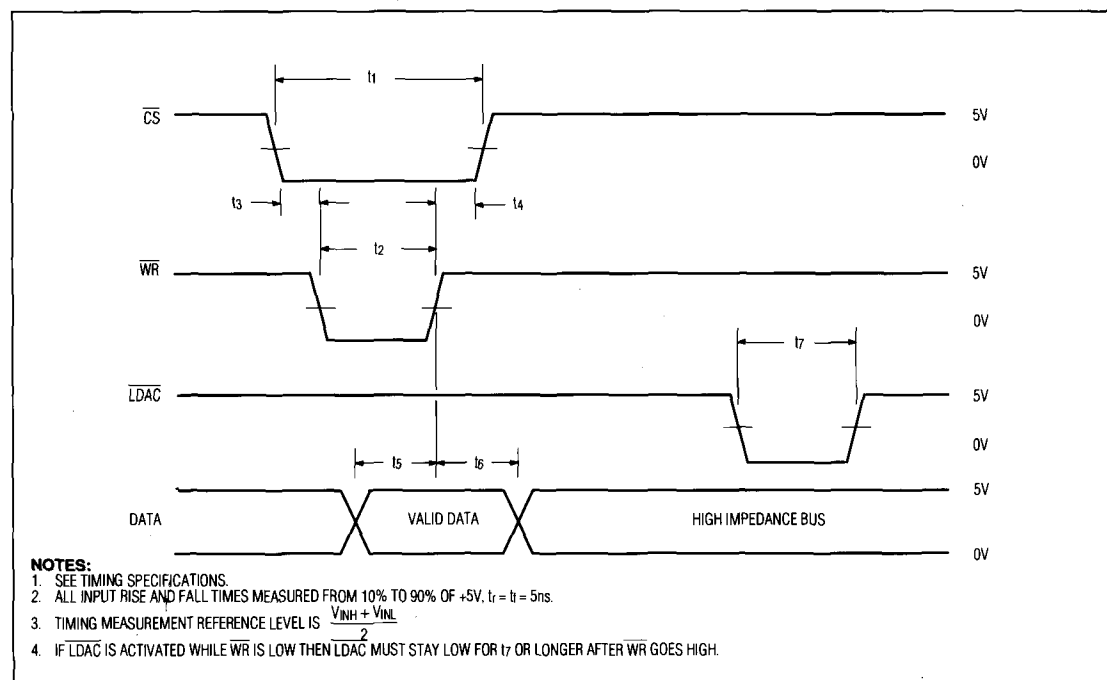

Figure 1. MX7245 Write-Cycle Timing Diagram

## Complete, 12-Bit Voltage-Output DACs

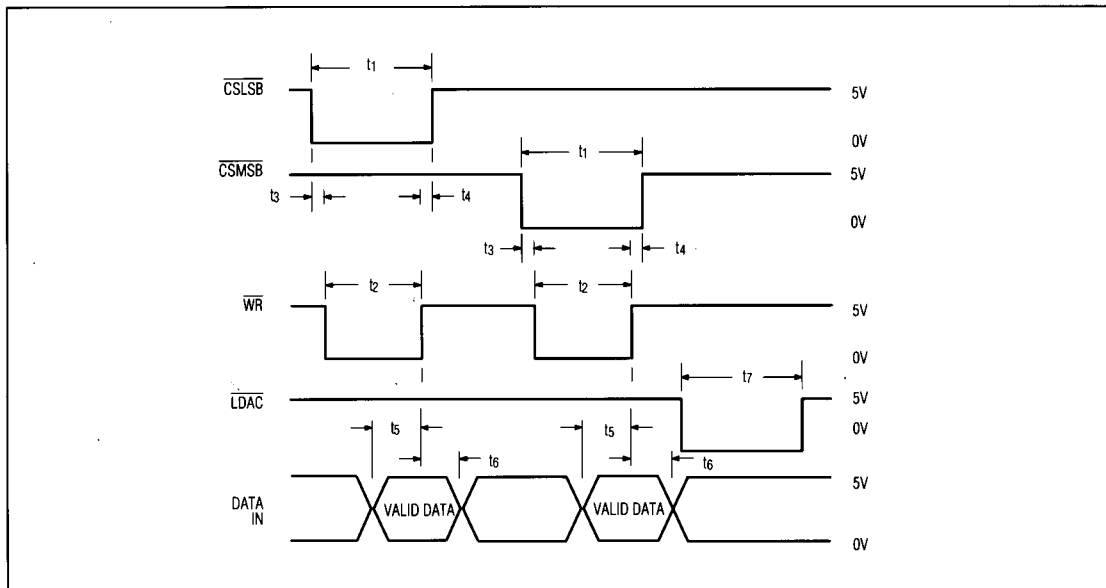

Figure 2. MX7248 Write-Cycle Timing Diagram

MX7245 PIN	MX7248 PIN	NAME	FUNCTION	MX7245 PIN	MX7248 PIN	NAME	FUNCTION
1	1	VSS	Negative Supply Voltage	13-17		D4-D0	Data Bits 4-0
2	2	ROFS	Bipolar Offset Resistor	18		CS	Chip-Select Input - active low
3	3	REFOUT	Reference Output		14	CSMSB	Chip-Select Input for the MSB nibble - active low
4	4	AGND	Analog Ground		15	CSLSB	Chip-Select Input for the LSB byte - active low
	5-8	D7-D4	Data Bits 7-4	19	16	WR	Write Input - active low
	9	D3/D11	Data Bits 3 and 11	20	17	LDAC	Load DAC Input - active low
	5-11	D11-D5	Data Bits 11-5	21		CLR	Clear Input - active low
12	10	DGND	Digital Ground	22	18	VDD	Positive Supply Voltage
	11	D2/D10	Data Bits 2 and 10	23	19	RFB	Feedback Resistor
	12	D1/D9	Data Bits 1 and 9	24	20	VOUT	Output Voltage
	13	D0-D8	Data Bits 0 and 8				

See MAX507/MAX508 data sheet for applications information.