



NT511740D5J DATA SHEET



Contents

Table of Contents	02
Description	03
Features	03
Product Family	03
Pin Assignment	04
Electrical Characteristics	05
Absolute Maximum Ratings	05
Recommended DC Operating Conditions	05
Capacitance	05
DC Electrical Characteristics	06
AC Characteristics	07
Timing Waveform	10
Read Cycle	10
Write Cycle	10
Read Modify Write Cycle	11
Fast Page Mode Read Cycle	11
Fast Page Mode Write Cycle	12
Fast Page Mode Read Modify Write Cycle	13
RAS -only Refresh Cycle	13
CAS -before- RAS refresh	14
Hidden Refresh Read	15
Package Dimension	16



DESCRIPTION

This is a family of 4,194,304 x 4 bit Extended Data Out CMOS DRAMs. Extended Data Out Mode offers high speed random access of memory cells within the same row, so called Hyper Page Mode. Power supply voltage (+5.0V), refresh cycle (2K Ref), access time (-5 or -6), power consumption (Normal or Low power) and package type (SOJ) are optional features of this family.

All of this family have $\overline{\text{CAS}}$ -before- $\overline{\text{RAS}}$ refresh, $\overline{\text{RAS}}$ -only refresh and Hidden refresh capabilities. Furthermore, Self-refresh operation is available in L-version. This 4Mx4 EDO Mode DRAM family is fabricated using NANYA's advanced CMOS process to realize high bandwidth, low power consumption and high reliability.

It may be used as main memory unit for microcomputer, high level computer and personal computer .

FEATURES

- Extended Data Out Mode operation (Fast Page Mode with Extended Data Out)
- TTL(5V) compatible inputs and outputs
- Single +5V \pm 10% power supply (5V product)
- JEDEC Standard pinout
- $\overline{\text{CAS}}$ before $\overline{\text{RAS}}$ refresh, hidden refresh, $\overline{\text{RAS}}$ -only refresh capability
- Refresh : 2048 cycles / 32 ms
- Self-refresh capability (L-ver only)
- Multi-bit test mode capability
- Available in plastic SOJ packages

PRODUCT FAMILY

Family	Access Time (Max.)				Active Power Dissipation	Voltage	Package
	tRAC	tCAC	tRC	tHPC			
NT511740D5J - 50/5L	50ns	15ns	84ns	20ns	605mW	5V	26(24)-pin SOJ
NT511740D5J - 60/6L	60ns	17ns	104ns	25ns	550mW		

PIN CONFIGURATION (TOP VIEW)

NT511740D5J

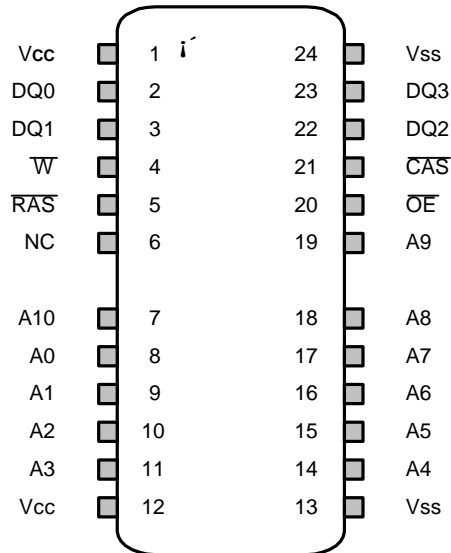

300mil 26(24)-pin SOJ

Pin Name	Pin Function
A0-A10	Address Inputs
DQ0-DQ3	Data Input / Output
Vss	Ground
\overline{RAS}	Row Address Strob
\overline{CAS}	Column Address Strob
\overline{W}	Read/Write Input
\overline{OE}	Data Output Enable
Vcc	Power +5.0 V (+ 3.3V)
NC	No Connection

ELECTRICAL CHARACTERISTICS

Absolute Maximum Ratings

Parameter	Symbol	Rating	Unit
Voltage on Any Pin Relative to V _{SS}	V _{IN} , V _{OUT}	-1.0 to +7.0	V
Voltage on V _{CC} Supply Relative to V _{SS}	V _{CC}	-1.0 to +7.0	V
Short Circuit Output Current	I _{OS}	50	mA
Power Dissipation	P _D *	1	W
Operation Temperature	T _{opr}	0 to 70	°C
Storage Temperature	T _{stg}	-55 to 150	°C

*: Ta = 25°C

- Permanent device damage may occur if "ABSOLUTE MAXIMUM RATINGS" are exceeded. Functional operation should be restricted to the conditions as detailed in the operational sections of this data sheet. Exposure to absolute maximum rating conditions for extended periods may affect device reliability.

Recommended Operating Conditions

(Voltage referenced to V_{SS}, Ta = 0°C to 70°C)

Parameter	Symbol	Min.	Typ.	Max.	Unit
Supply Voltage	V _{CC}	4.5	5.0	5.5	V
Ground	V _{SS}	0	0	0	V
Input High Voltage	V _{IH}	2.4	-	V _{CC} +1.0 ^{*1}	V
Input Low Voltage	V _{IL}	-1.0 ^{*2}	-	0.8	V

*1 : V_{CC} +2.0V/20ns(5V), Pulse width is measured at V_{CC}*2 : -2.0V/20ns(5V), Pulse width is measured at V_{SS}

Capacitance

(V_{CC} = 5V, Ta = 25°C, f = 1 MHz)

Parameter	Symbol	Typ.	Max.	Unit
Input Capacitance (A0-A11)	C _{IN1}	-	5	pF
Input Capacitance ($\overline{\text{RAS}}$, $\overline{\text{CAS}}$, $\overline{\text{WE}}$, $\overline{\text{OE}}$)	C _{IN2}	-	7	pF
Output Capacitance (DQ0-DQ3)	C _{I/O}	-	7	pF

DC Characteristics

(Recommended operating conditions unless otherwise noted.)

Max	Parameter	Symbol	Min	Max	Units
5V	Input Leakage Current (Any input 0 ≤ V _{IN} ≤ V _{IN} +0.5V, all other input pins not under test =0 Volt)	I _{I(L)}	-5	5	uA
	Output Leakage Current (Data out is disabled, 0 ≤ V _{OUT} ≤ V _{CC})	I _{O(L)}	-5	5	uA
	Output High Voltage Level (I _{OH} = -5mA)	V _{OH}	2.4	-	V
	Output Low Voltage Level (I _{OL} =4.2mA)	V _{OL}	-	0.4	V

DC CHARACTERISTICS (Continued)

Symbol	Power	Speed	Max	Units
ICC1	Don't care	-5	110	mA
		-6	100	mA
ICC2	Normal	Don't care	2	mA
	L		1	mA
ICC3	Don't care	-5	110	mA
		-6	100	mA
ICC4	Don't care	-5	90	mA
		-6	80	mA
ICC5	Normal	Don't care	3	mA
	L		200	uA
ICC6	Don't care	-5	110	mA
		-6	100	mA
ICC7	L	Don't care	300	uA
ICCS	L	Don't care	250	uA

ICC1* : Operating Current (\overline{RAS} and \overline{CAS} cycling @ $t_{RC}=\text{min.}$)

ICC2 : Standby Current ($\overline{RAS} = \overline{CAS} = \overline{W} = V_{IH}$)

ICC3* : \overline{RAS} -only Refresh Current ($\overline{RAS}=V_{IH}$, \overline{RAS} cycling @ $t_{RC}=\text{min.}$)

ICC4* : Hyper Page Mode Current ($\overline{RAS}=V_{IL}$, \overline{CAS} Address cycling @ $t_{HPC}=\text{min.}$)

ICC5 : Standby Current ($\overline{RAS} = \overline{CAS} = \overline{W} = V_{CC}-0.2V$)

ICC6* : CAS-Before- \overline{RAS} Refresh Current (\overline{RAS} , \overline{CAS} Cycling @ $t_{RC}=\text{min.}$)

ICC7 : Battery back-up current, Average power supply current, Battery back-up mode Input high voltage (V_{IH})= $V_{CC}-0.2V$, Input low voltage (V_{IL})= $0.2V$, $\overline{CAS}=0.2V$, $DQ=\text{Don't care}$, $t_{RC}=125\mu\text{s}(2K/L\text{-ver})$, $t_{RAS}=t_{RAS\text{min}}\sim 300\text{ns}$

ICCS : Self Refresh Current

($\overline{RAS} = \overline{CAS}=0.2V$, $\overline{W} = \overline{OE}=A0 \sim A11=V_{CC}-0.2V$ or $0.2V$, $DQ0 \sim DQ3=V_{CC}-0.2V$, $0.2V$ or open)

*Note : ICC1, ICC3, ICC4 and ICC6 are dependent on output loading and cycle rates. Specified values are obtained with the output open. ICC is specified as an average current. In ICC1, ICC3 and ICC6, address can be changed maximum once while $\overline{RAS}=V_{IL}$. In ICC4, address can be changed maximum once within one hyper page mode cycle time, t_{HPC} .

AC CHARACTERISTICS

(0°C ≤ Ta ≤ 70°C , See note 1,2) ; Test condition : VCC=5.0V ± 10%, VIH/VIL=2.4/0.8V, VOH/VOL=2.0/0.8V

Parameter	Symbol	-50		-60		Unit	Notes
		Min	Max	Min	Max		
Random read or write cycle time	t RC	84	-	104	-	ns	
Read-modify-write cycle time	t RWC	110		135		ns	
Access time from $\overline{\text{RAS}}$	t RAC		50		60	ns	3,4,10
Access time from $\overline{\text{CAS}}$	t CAC		13		15	ns	3,4,5
Access time from column address	t AA		25		30	ns	3,10
$\overline{\text{CAS}}$ to output in Low-Z	t CLZ	0		0		ns	3
Output buffer turn-off delay from $\overline{\text{CAS}}$	t CEZ	0		0		ns	6,14
$\overline{\text{OE}}$ to output in Low-Z	t OLZ	0		0		ns	3
Transition time (rise and fall)	t T	1		1		ns	2
$\overline{\text{RAS}}$ precharge time	t RP	30		40		ns	
$\overline{\text{RAS}}$ pulse width	t RAS	50		60		ns	
$\overline{\text{RAS}}$ hold time	t RSH	7		10		ns	
$\overline{\text{CAS}}$ hold time	t CSH	35		40		ns	
$\overline{\text{CAS}}$ pulse width	t CAS	7		10		ns	
$\overline{\text{RAS}}$ to $\overline{\text{CAS}}$ delay time	t RCD	11		14		ns	4
$\overline{\text{RAS}}$ to column address delay time	t RAD	9		12		ns	10
$\overline{\text{CAS}}$ to $\overline{\text{RAS}}$ precharge time	t CRP	5		5		ns	
Row address set-up time	t ASR	0		0		ns	
Row address hold time	t RAH	7		10		ns	
Column address set-up time	t ASC	0		0		ns	
Column address hold time	t CAH	7		10		ns	
Column address to $\overline{\text{RAS}}$ lead time	t RAL	25		30		ns	
Read command set-up time	t RCS	0		0		ns	
Read command hold time referenced to $\overline{\text{CAS}}$	t RCH	0		0		ns	8
Read command hold time referenced to $\overline{\text{RAS}}$	t RRH	0		0		ns	8
Write command hold time	t WCH	7		10		ns	
Write command pulse width	t WP	7		10		ns	
Write command to $\overline{\text{RAS}}$ lead time	t RWL	7		10		ns	
Write command to $\overline{\text{CAS}}$ lead time	t CWL	7		10		ns	
Data set-up time	t DS	0		0		ns	9
Data hold time	t DH	7		10		ns	9
Refresh period (2K, Normal)	t REF		32		32	ms	
Refresh period (L-ver)	t REF		128		128	ms	
Write command set-up time	t WCS	0		0		ns	7

AC CHARACTERISTICS (Continued)

Parameter	Symbol	-50		-60		Unit	Notes
		Min	Max	Min	Max		
$\overline{\text{CAS}}$ to $\overline{\text{W}}$ delay time	t CWD	30		34		ns	7
$\overline{\text{RAS}}$ to $\overline{\text{W}}$ delay time	t RWD	67		79		ns	7
Column address to $\overline{\text{W}}$ delay time	t AWD	42		49		ns	7
$\overline{\text{CAS}}$ precharge to $\overline{\text{W}}$ delay time	t CPWD	47		54		ns	
$\overline{\text{CAS}}$ set-up time ($\overline{\text{CAS}}$ -before- $\overline{\text{RAS}}$ refresh)	t CSR	5		5		ns	
$\overline{\text{CAS}}$ hold time ($\overline{\text{CAS}}$ -before- $\overline{\text{RAS}}$ refresh)	t CHR	10		10		ns	
$\overline{\text{RAS}}$ to CAS precharge time	t RPC	5		5		ns	
Access time from $\overline{\text{CAS}}$ precharge	t CPA		28		35	ns	3
Hyper Page cycle time	t HPC	20		25		ns	13
Hyper Page read-modify-write cycle time	t HPRWC	47		56		ns	13
$\overline{\text{CAS}}$ precharge time (Hyper Page cycle)	t CP	7		10		ns	
$\overline{\text{RAS}}$ pulse width (Hyper Page cycle)	t RASP	50	100k	60	100k	ns	
$\overline{\text{RAS}}$ hold time from $\overline{\text{CAS}}$ precharge	t RHCP	30		35		ns	
$\overline{\text{OE}}$ access time	t OEA		13		15	ns	
$\overline{\text{OE}}$ to data delay	t OED	12		15		ns	
Output buffer turn off delay time from $\overline{\text{OE}}$	t OEZ	3		3		ns	6
$\overline{\text{OE}}$ command hold time	t OEH	7		10		ns	
Write command set-up time (Test mode in)	t WTS	7		10		ns	11
Write command hold time (Test mode in)	t WTH	10		10		ns	11
$\overline{\text{W}}$ to $\overline{\text{RAS}}$ precharge time(C-B-R refresh)	t WRP	10		10		ns	
$\overline{\text{W}}$ to $\overline{\text{RAS}}$ hold time(C-B-R refresh)	t WRH	10		10		ns	
Output data hold time	t DOH	5		5		ns	
Output buffer turn off delay from $\overline{\text{RAS}}$	t REZ	0		0		ns	6,14
Output buffer turn off delay from $\overline{\text{W}}$	t WEZ	0		0		ns	6
$\overline{\text{W}}$ to data delay	t WED	10		10		ns	
$\overline{\text{OE}}$ to $\overline{\text{CAS}}$ hold time	t OCH	5		5		ns	
$\overline{\text{CAS}}$ hold time to OE	t CHO	5		5		ns	
$\overline{\text{OE}}$ precharge time	t OEP	7		10		ns	
$\overline{\text{W}}$ pulse width (Hyper Page Cycle)	t WPE	7		10		ns	
$\overline{\text{RAS}}$ pulse width (C-B-R self refresh)	t RASS	100		100		ns	15,16,17
$\overline{\text{RAS}}$ precharge time (C-B-R self refresh)	t RPS	90		110		ns	15,16,17
$\overline{\text{CAS}}$ hold time (C-B-R self refresh)	t CHS	-50		-50		ns	15,16,17



NOTES

1. An initial pause of 200us is required after power-up followed by any 8 $\overline{\text{RAS}}$ -only refresh or $\overline{\text{CAS}}$ -before- $\overline{\text{RAS}}$ refresh Cycles before proper device operation is achieved.
2. VIH(min) and VIL(max) are reference levels for measuring timing of input signals. Transition times are measured between VIH(min) and VIL(max) and are assumed to be 2ns for all inputs.
3. Measured with a load equivalent to 2 TTL(5V)/1 TTL(3.3V) loads and 100pF.
4. Operation within the tRCD(max) limit insures that tRAC(max) can be met. tRCD(max) is specified as a reference point only. If tRCD is greater than the specified tRCD (max) limit, then access time is controlled exclusively by tCAC.
5. Assumes that tRCD >= tRCD(max).
6. This parameter defines the time at which the output achieves the open circuit condition and is not referenced to VOH or VOL.
7. tWCS, tRWD, tCWD and tAWD are non restrictive operating parameters. They are included in the data sheet as electrical characteristics only. If tWCS >= tWCS(min), the cycle is an early write cycle and the data output will remain high impedance for the duration of the cycle. If tCWD >= tCWD(min), tRWD >= tRWD(min) and tAWD >= tAWD(min), then the cycle is a read-modify-write cycle and the data output will contain the data read from the selected address. If neither of the above conditions is satisfied, the condition of the data out is indeterminate. Either tRCH or tRRH must be satisfied for a read cycle.
8. These parameters are referenced to $\overline{\text{CAS}}$ falling edge in early write cycles and to $\overline{\text{W}}$ falling edge in $\overline{\text{OE}}$ controlled Write Cycle and read-modify-write cycles.
9. Operation within the tRAD (max) limit insures that tRAD(max) can be met. tRAD(max) is specified as a reference point only. If tRAD is greater than the specified tRAD(max) limit, then access time is controlled by tAA .
10. These specifications are applied in the test mode.
11. In test mode read cycle, the value of tRAC, tAA, tCAC is delayed by 2ns to 5ns for the specified values. These Parameters should specified in test mode cycles by adding the above value to the specified value in this data sheet.
12. tASC >= 6ns, Assume t τ = 2.0ns
13. If $\overline{\text{RAS}}$ goes high before $\overline{\text{CAS}}$ high going, the open circuit condition of the output is achieved by $\overline{\text{CAS}}$ high going.
If $\overline{\text{CAS}}$ goes high before $\overline{\text{RAS}}$ high going, the open circuit condition of the output is achieved by $\overline{\text{RAS}}$ high going.
14. If tRASS >= 100us, then $\overline{\text{RAS}}$ precharge time must use tRPS instead of tRP.
15. For RAS-only refresh and burst $\overline{\text{CAS}}$ -before- $\overline{\text{RAS}}$ refresh mode, 2048(2K) cycles of burst refresh must be executed within 32ms before and after self refresh, in order to meet refresh specification..
16. For distributed $\overline{\text{CAS}}$ -before- $\overline{\text{RAS}}$ with 15.6us interval $\overline{\text{CAS}}$ -before- $\overline{\text{RAS}}$ refresh should be executed with in 15.6us immediately before and after self refresh in order to meet refresh specification.

TIMING WAVEFORM

Read Cycle

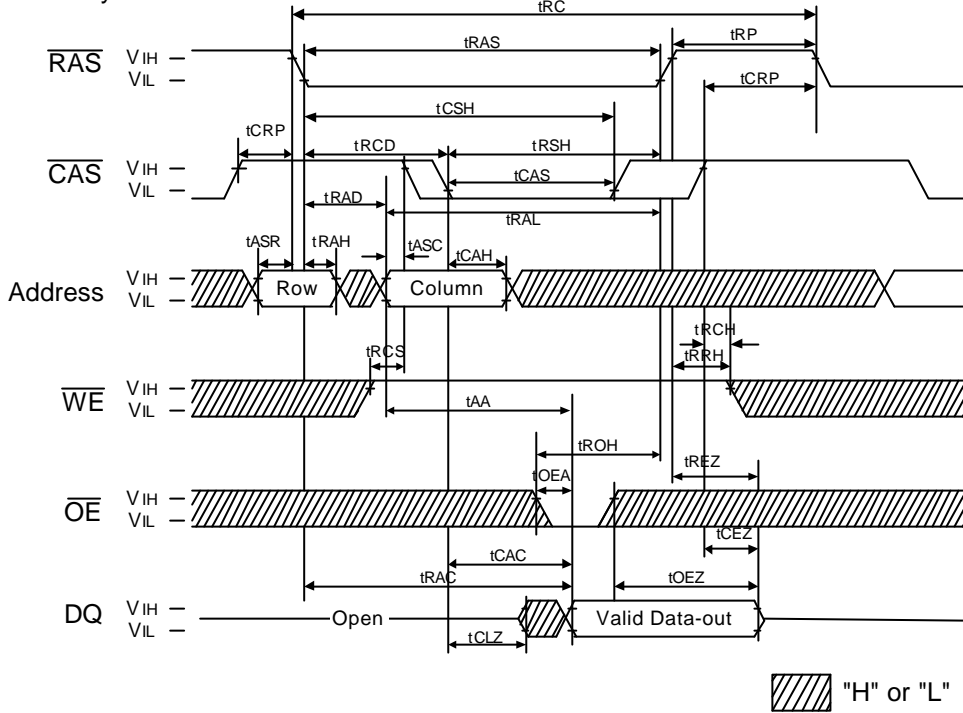

Write Cycle(Early Write)

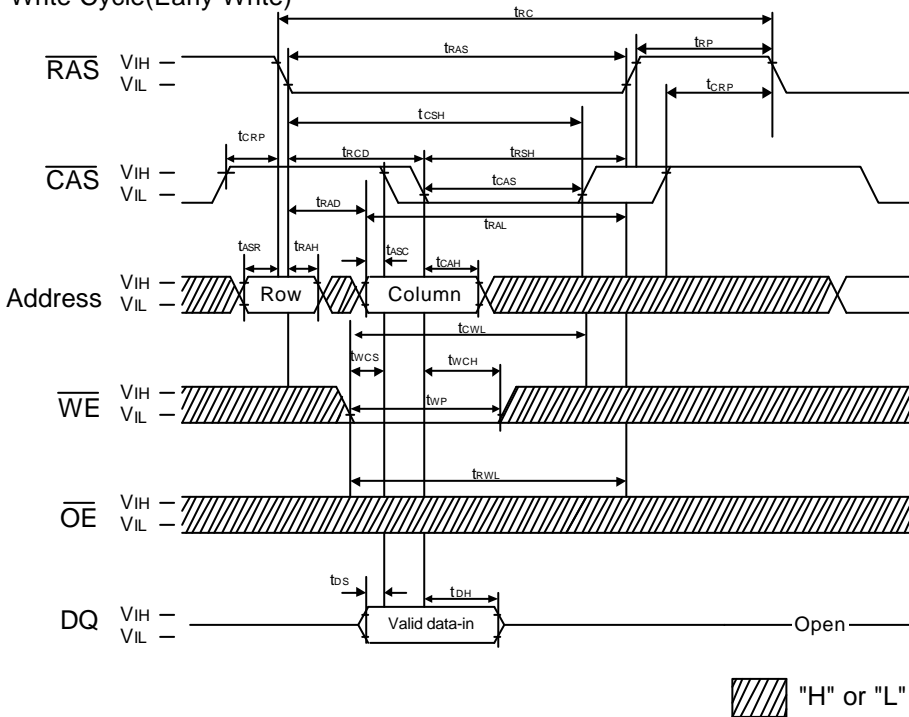



Fast Page Mode Read Cycle(Part-2)

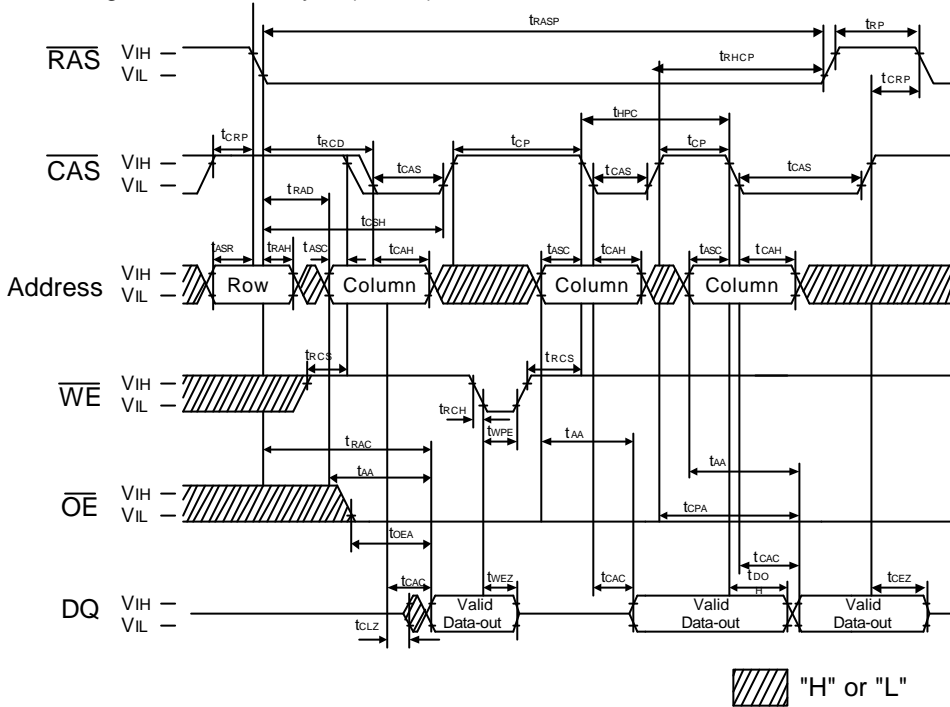

Fast page Mode Write Cycle(Early Write)

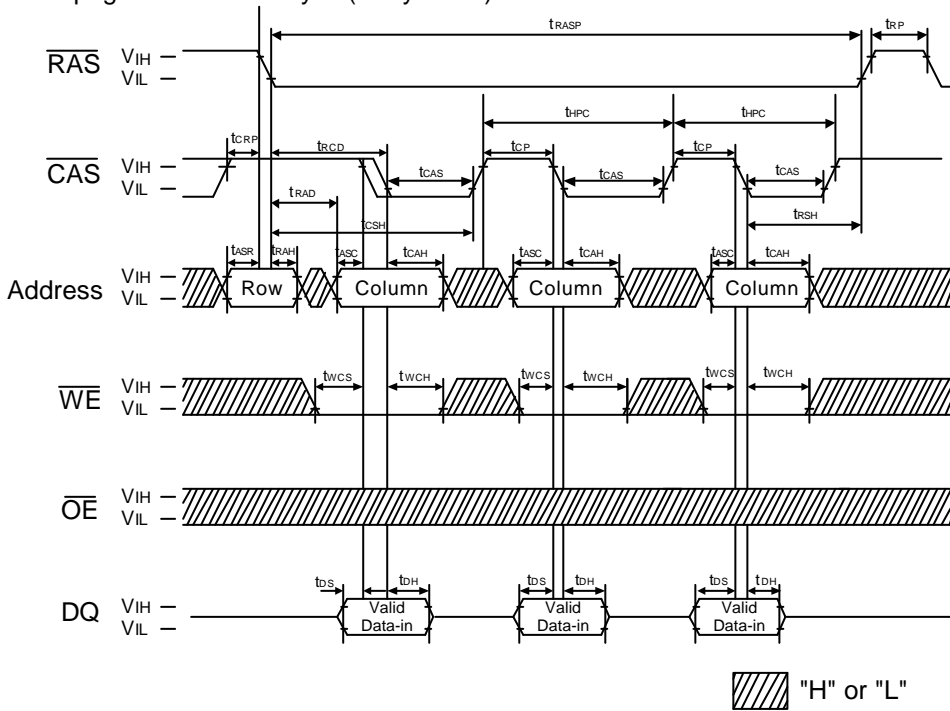

Fast Page Mode Read Modify Write Cycle

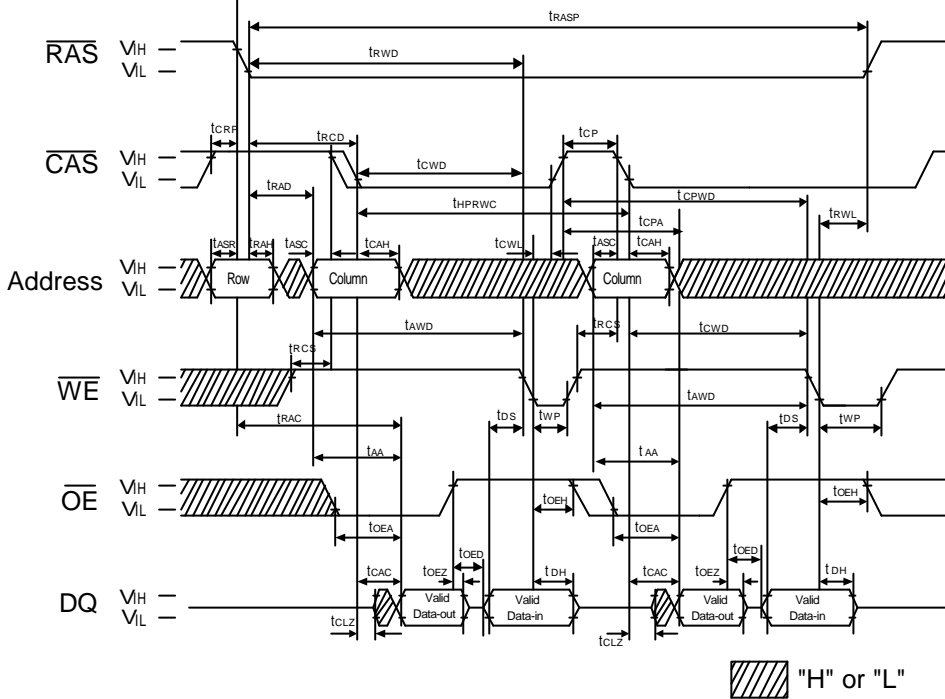

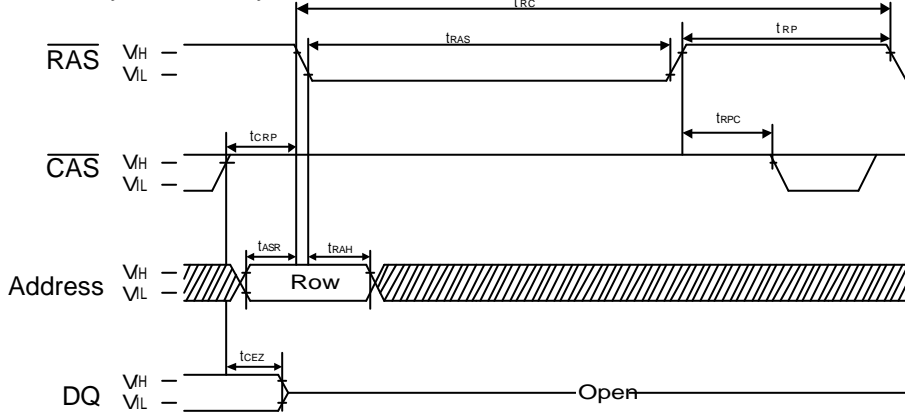

RAS-only Refresh Cycle

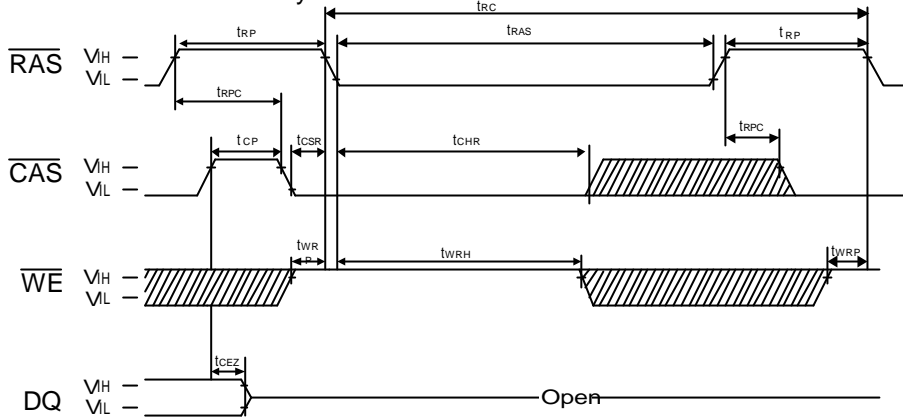

Note: $\overline{WE}, \overline{OE}$ = "H" or "L"  "H" or "L"

$\overline{\text{CAS}}$ before $\overline{\text{RAS}}$ Refresh Cycle



Note: $\overline{\text{OE}}$, Address="H" or "L"  "H" or "L"

Hidden Refresh Read Cycle

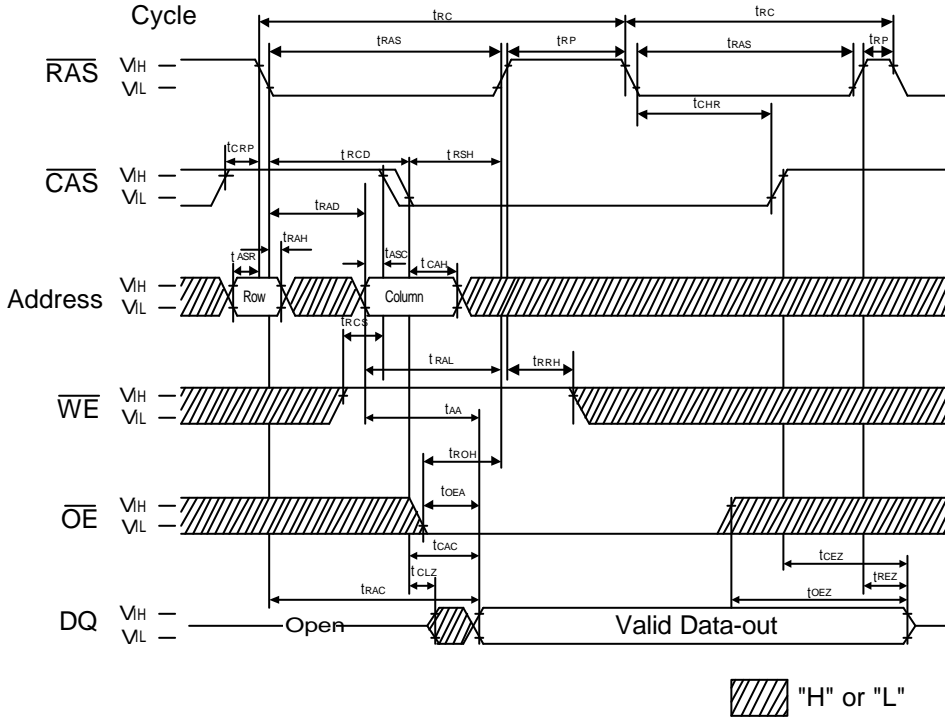

 "H" or "L"

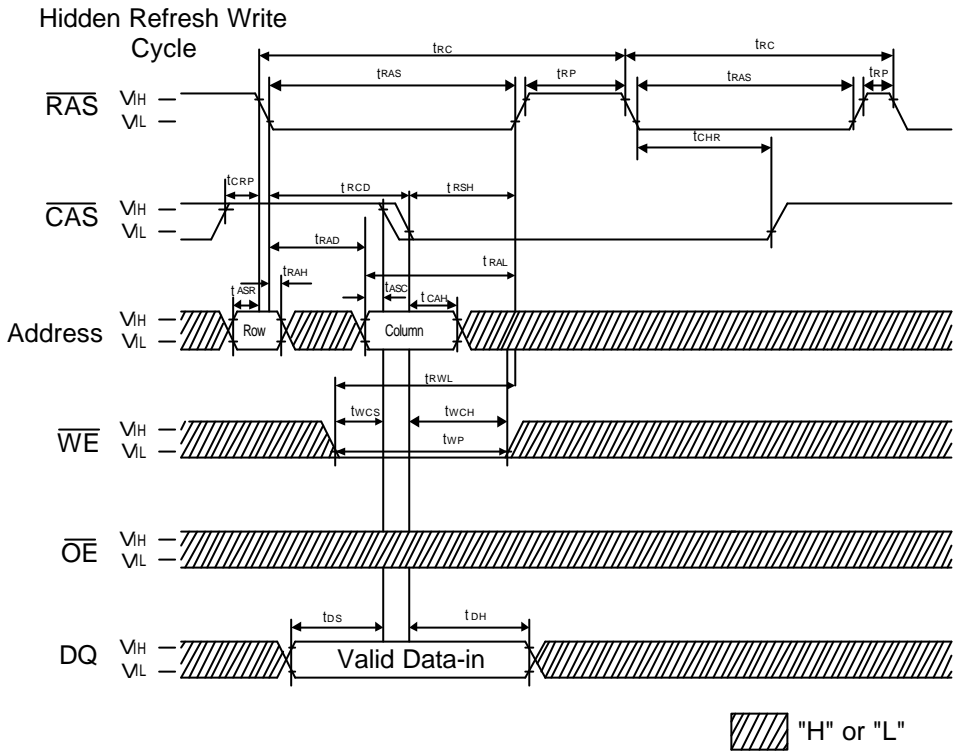

NT511740D5J

16MEG : x4
CMOS with Extended Data Out



PACKAGE DIMENSION

24/26-PIN PLASTIC SOJ (300mil)

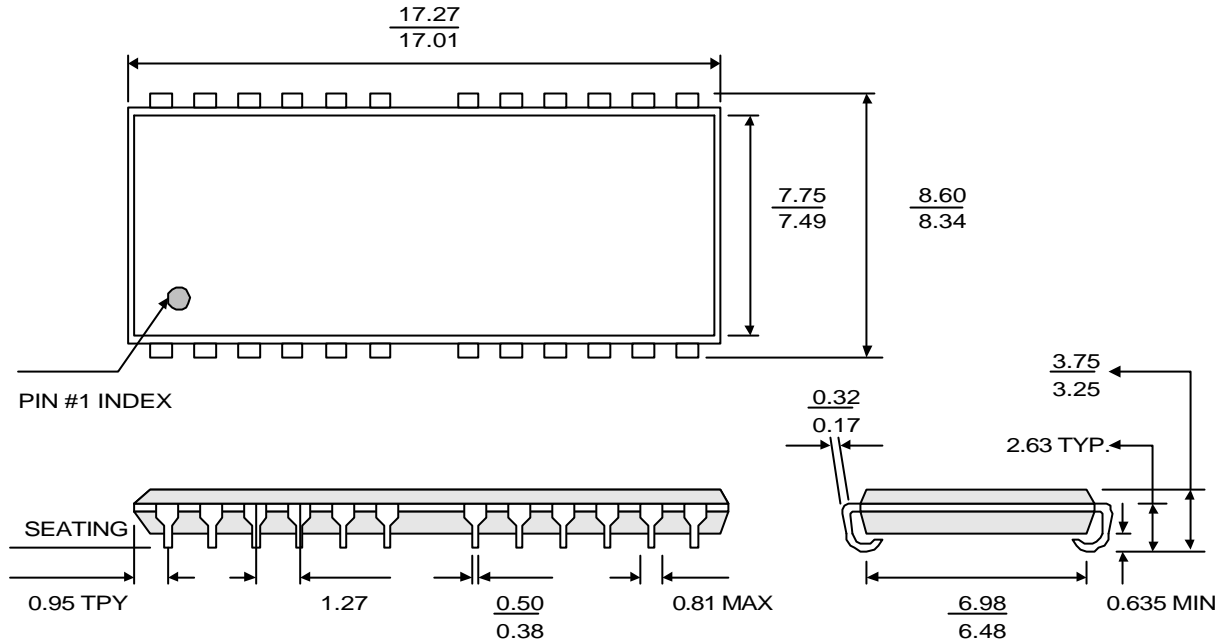

NOTE : All dimensions in millimeters $\frac{\text{MAX}}{\text{MIN}}$ or typical where noted.