

DATA SHEET

SA575

Low voltage compandor

Product specification
Replaces data of 1997 June 28
IC17

1997 Nov 07

Philips Semiconductors



PHILIPS

Low voltage compandor

SA575

DESCRIPTION

The SA575 is a precision dual gain control circuit designed for low voltage applications. The SA575's channel 1 is an expander, while channel 2 can be configured either for expander, compressor, or automatic level controller (ALC) application.

FEATURES

- Operating voltage range from 3V to 7V
- Reference voltage of $100\text{mV}_{\text{RMS}} = 0\text{dB}$
- One dedicated summing op amp per channel and two extra uncommitted op amps
- 600Ω drive capability
- Single or split supply operation
- Wide input/output swing capability
- 3000V ESD protection

APPLICATIONS

- Portable communications
- Cellular radio
- Cordless telephone
- Consumer audio

PIN CONFIGURATION

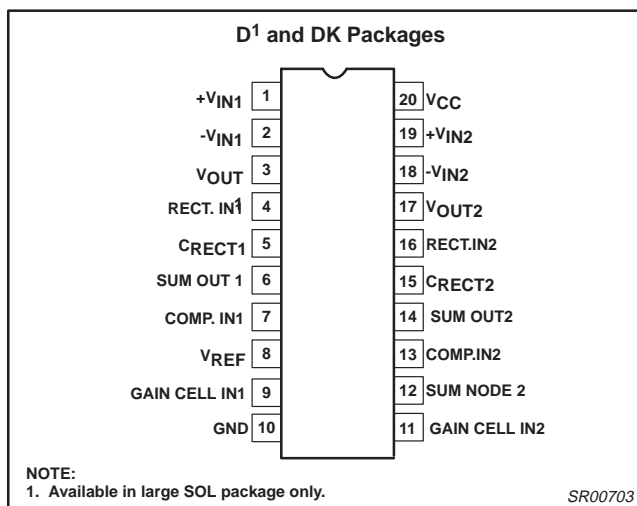

Figure 1. Pin Configuration

- Portable broadcast mixers
- Wireless microphones
- Modems
- Electric organs
- Hearing aids

ORDERING INFORMATION

DESCRIPTION	TEMPERATURE RANGE	ORDER CODE	DWG
20-Pin Plastic Small Outline Large	-40 to +85°C	SA575D	SOT163-1
20-Pin Plastic Shrink Small Outline Package (SSOP)	-40 to +85°C	SA575DK	SOT266-1

ABSOLUTE MAXIMUM RATINGS

SYMBOL	PARAMETER	RATING	UNITS	
		SA575		
V_{CC}	Single supply voltage	-0.3 to 8	V	
V_{IN}	Voltage applied to any other pin	-0.3 to ($V_{CC}+0.3$)	V	
T_A	Operating ambient temperature range	-40 to +85	°C	
T_{STG}	Storage temperature range	-65 to +150	°C	
θ_{JA}	Thermal impedance	SOL	112	°C/W
		SSOP	117	°C/W

Low voltage compandor

SA575

BLOCK DIAGRAM and TEST CIRCUIT

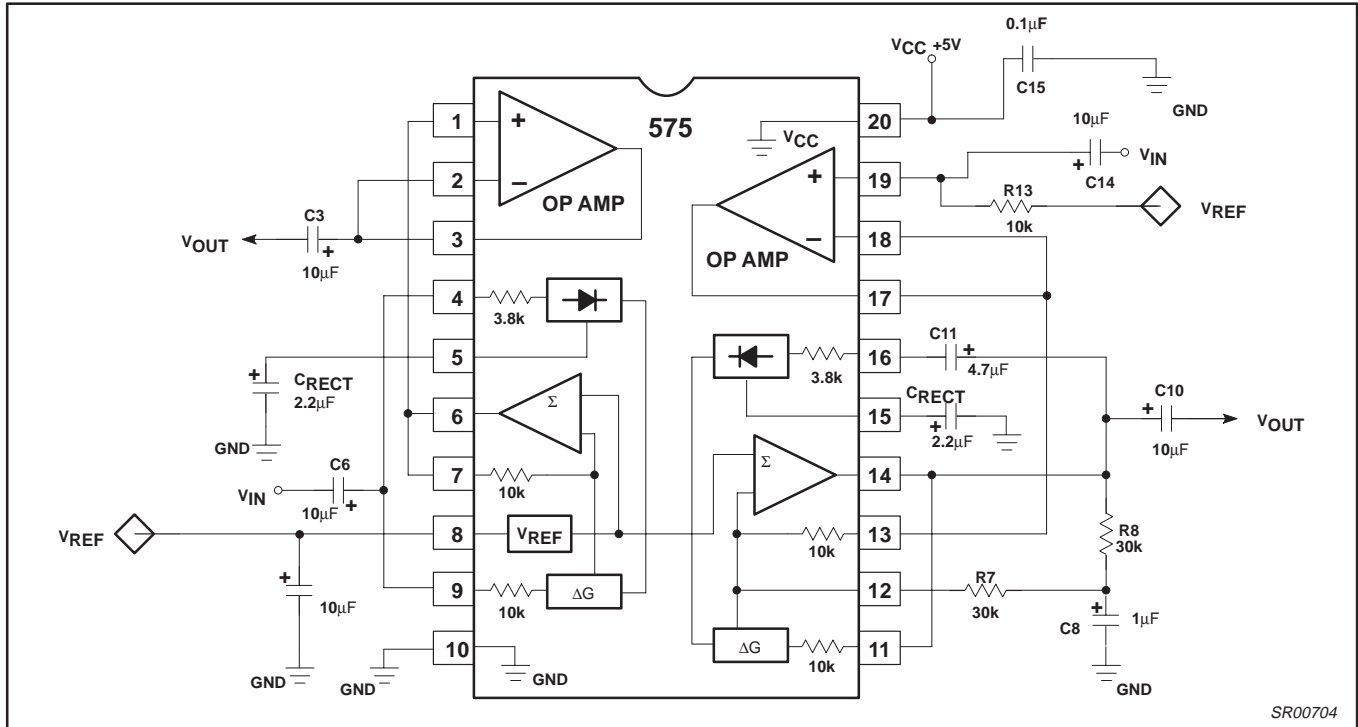

Figure 2. Block Diagram and Test Circuit

DC ELECTRICAL CHARACTERISTICS

Typical values are at $T_A = 25^\circ\text{C}$. Minimum and Maximum values are for the full operating temperature range: -40 to $+85^\circ\text{C}$ for SA575, except SSOP package is tested at $+25^\circ\text{C}$ only. $V_{CC} = 5\text{V}$, unless otherwise stated. Both channels are tested in the Expander mode (see Test Circuit)

SYMBOL	PARAMETER	TEST CONDITIONS	LIMITS			UNITS
			SA575			
			MIN	TYP	MAX	
For compandor, including summing amplifier						
V_{CC}	Supply voltage ¹		3	5	7	V
I_{CC}	Supply current	No signal	3	4.2	5.5	mA
V_{REF}	Reference voltage ²	$V_{CC} = 5\text{V}$	2.4	2.5	2.6	V
R_L	Summing amp output load		10			k Ω
THD	Total harmonic distortion	1kHz, 0dB BW = 3.5kHz		0.12	1.5	%
E_{NO}	Output voltage noise	BW = 20kHz, $R_S = 0\Omega$		6	30	μV
0dB	Unity gain level	1kHz	-1.5		1.5	dB
V_{OS}	Output voltage offset	No signal	-150		150	mV
	Output DC shift	No signal to 0dB	-100		100	mV
	Tracking error relative to 0dB	Gain cell input = 0dB, 1kHz Rectifier input = 6dB, 1kHz	-1.0		1.0	dB
		Gain cell input = 0dB, 1kHz Rectifier input = -30dB, 1kHz	-1.0		1.0	dB

Low voltage compandor

SA575

DC ELECTRICAL CHARACTERISTICS (cont.)

SYMBOL	PARAMETER	TEST CONDITIONS	LIMITS			UNITS
			SA575			
			MIN	TYP	MAX	
	Crosstalk	1kHz, 0dB, $C_{REF} = 220\mu\text{F}$		-80	-65	dB
For operational amplifier						
V_O	Output swing	$R_L = 10\text{k}\Omega$	$V_{CC}-0.4$	V_{CC}		V
R_L	Output load	1kHz	600			Ω
CMR	Input common-mode range		0		V_{CC}	V
CMRR	Common-mode rejection ratio		60	80		dB
I_B	Input bias current	$V_{IN} = 0.5\text{V to } 4.5\text{V}$	-1		1	μA
V_{OS}	Input offset voltage			3		mV
A_{VOL}	Open-loop gain	$R_L = 10\text{k}\Omega$		80		dB
SR	Slew rate	Unity gain		1		V/ μs
GBW	Bandwidth	Unity gain		3		MHz
E_{NI}	Input voltage noise	BW = 20kHz		2.5		μV
PSRR	Power supply rejection ratio	1kHz, 250mV		60		dB

NOTES:

1. Operation down to $V_{CC} = 2\text{V}$ is possible, but performance is reduced. See curves in Figure 7a and 7b.
2. Reference voltage, V_{REF} , is typically at $1/2V_{CC}$.

FUNCTIONAL DESCRIPTION

This section describes the basic subsystems and applications of the SA575 Comandor. More theory of operation on comandors can be found in AN174 and AN176. The typical applications of the SA575 low voltage comandor in an Expandor (1:2), Compressor (2:1) and Automatic Level Control (ALC) function are explained. These three circuit configurations are shown in Figures 3, 4, 5 respectively.

The SA575 has two channels for a complete companding system. The left channel, A, can be configured as a 1:2 Expandor while the right channel, B, can be configured as either a 2:1 Compressor, a 1:2 Expandor or an ALC. Each channel consists of the basic companding building blocks of rectifier cell, variable gain cell, summing amplifier and V_{REF} cell. In addition, the SA575 has two additional high performance uncommitted op amps which can be utilized for application such as filtering, pre-emphasis/de-emphasis or buffering.

Figure 6 shows the complete schematic for the applications demo board. Channel A is configured as an expandor while channel B is configured so that it can be used either as a compressor or as an ALC circuit. The switch, S1, toggles the circuit between compressor and ALC mode. Jumpers J1 and J2 can be used to either include the additional op amps for signal conditioning or exclude them from the signal path. Bread boarding space is provided for R1, R2, C1, C2, R10, R11, C10 and C11 so that the response can be tailored for each individual need. The components as specified are suitable for the complete audio spectrum from 20Hz to 20kHz.

The most common configuration is as a unity gain non-inverting buffer where R1, C1, C2, R10, C10 and C11 are eliminated and R2 and R11 are shorted. Capacitors C3, C5, C8, and C12 are for DC blocking. In systems where the inputs and outputs are AC coupled, these capacitors and resistors can be eliminated. Capacitors C4 and C9 are for setting the attack and release time constant.

C6 is for decoupling and stabilizing the voltage reference circuit. The value of C6 should be such that it will offer a very low impedance to the lowest frequencies of interest. Too small a capacitor will allow supply ripple to modulate the audio path. The

better filtered the power supply, the smaller this capacitor can be. R12 provides DC reference voltage to the amplifier of channel B. R6 and R7 provide a DC feedback path for the summing amp of channel B, while C7 is a short-circuit to ground for signals. C14 and C15 are for power supply decoupling. C14 can also be eliminated if the power supply is well regulated with very low noise and ripple.

DEMONSTRATED PERFORMANCE

The applications demo board was built and tested for a frequency range of 20Hz to 20kHz with the component values as shown in Figure 6 and $V_{CC} = 5\text{V}$. In the expandor mode, the typical input dynamic range was from -34dB to +12dB where 0dB is equal to 100mV_{RMS} . The typical unity gain level measured at 0dB @ 1kHz input was $\pm 0.5\text{dB}$ and the typical tracking error was $\pm 0.1\text{dB}$ for input range of -30 to +10dB.

In the compressor mode, the typical input dynamic range was from -42dB to $\pm 18\text{dB}$ with a tracking error $\pm 0.1\text{dB}$ and the typical unity gain level was $\pm 0.5\text{dB}$.

In the ALC mode, the typical input dynamic range was from -42dB to +8dB with typical output deviation of $\pm 0.2\text{dB}$ about the nominal output of 0dB. For input greater than +9dB in ALC configuration, the summing amplifier sometimes exhibits high frequency oscillations. There are several solutions to this problem. The first is to lower the values of R6 and R7 to $20\text{k}\Omega$ each. The second is to add a current limiting resistor in series with C12 at Pin 13. The third is to add a compensating capacitor of about 22 to 30pF between the input and output of summing amplifier (Pins 12 and 14). With any one of the above recommendations, the typical ALC mode input range increased to +18dB yielding a dynamic range of over 60dB.

EXPANDOR

The typical expandor configuration is shown in Figure 3. The variable gain cell and the rectifier cell are in the signal input path. The V_{REF} is always $1/2 V_{CC}$ to provide the maximum headroom without clipping. The 0dB ref is 100mV_{RMS} . The input is AC coupled through C5, and the output is AC coupled through C3. If in a system the inputs and outputs are AC coupled, then C3 and C5 can be eliminated, thus requiring only one external component, C4. The variable gain cell and rectifier cell are DC coupled so any offset

Low voltage compandor

SA575

voltage between Pins 4 and 9 will cause small offset error current in the rectifier cell. This will affect the accuracy of the gain cell. This can be improved by using an extra capacitor from the input to Pin 4 and eliminating the DC connection between Pins 4 and 9.

The expander gain expression and the attack and release time constant is given by Equation 1 and Equation 2, respectively.

Equation 1.

$$\text{Expander gain} = \frac{4V_{IN(avg)}}{3.8k \times 100\mu A}$$

where $V_{IN(avg)} = 0.95V_{IN(RMS)}$

Equation 2.

$$\tau_R = \tau_A = 10k \times C_{RECT} = 10k \times C4$$

COMPRESSOR

The typical compressor configuration is shown in Figure 4. In this mode, the rectifier cell and variable gain cell are in the feedback path. R6 and R7 provide the DC feedback to the summing amplifier. The input is AC coupled through C12 and output is AC coupled through C8. In a system with inputs and outputs AC coupled, C8 and C12 could be eliminated and only R6, R7, C7, and C13 would be required. If the external components R6, R7 and C7 are eliminated, then the output of the summing amplifier will motor-boop in absence of signals or at extremely low signals. This is because there is no DC feedback path from the output to input. In the presence of an AC signal this phenomenon is not observed and the circuit will appear to function properly.

The compressor gain expression and the attack and release time constant is given by Equation 3 and Equation 4, respectively.

Equation 3.

$$\text{Compressor gain} = \left[\frac{3.8k \times 100\mu A}{4V_{IN(avg)}} \right]^{1/2}$$

where $V_{IN(avg)} = 0.95V_{IN(RMS)}$

Equation 4.

$$\tau_R = \tau_A = 10k \times C_{RECT} = 10k \times C4$$

AUTOMATIC LEVEL CONTROL

The typical Automatic Level Control circuit configuration is shown in Figure 5. It can be seen that it is quite similar to the compressor schematic except that the input to the rectifier cell is from the input path and not from the feedback path. The input is AC coupled through C12 and C13 and the output is AC coupled through C8. Once again, as in the previous cases, if the system input and output signals are already AC coupled, then C12, C13 and C8 could be eliminated. Concerning the compressor, removing R6, R7 and C7 will cause motor-booping in absence of signals. C_{COMP} is necessary to stabilize the summing amplifier at higher input levels. This circuit provides an input dynamic range greater than 60dB with the output within $\pm 0.5dB$ typical. The necessary design expressions are given by Equation 5 and Equation 6, respectively.

Equation 5.

$$\text{ALC gain} = \frac{3.8k \times 100\mu A}{4V_{IN(avg)}}$$

Equation 6.

$$\tau_R = \tau_A = 10k \times C_{RECT} = 10k \times C9$$

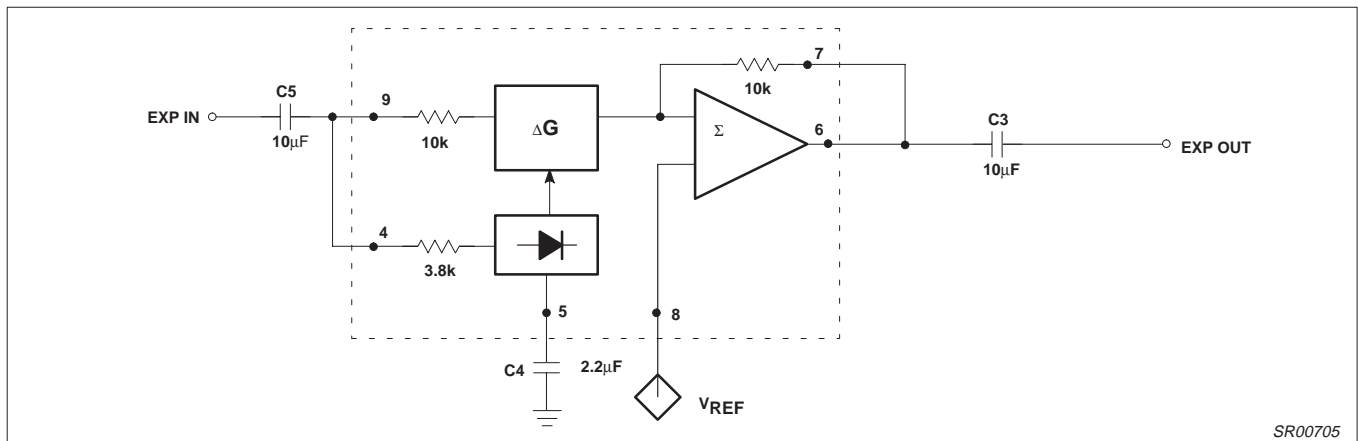

Figure 3. Typical Expander Configuration

SR00705

Low voltage compandor

SA575

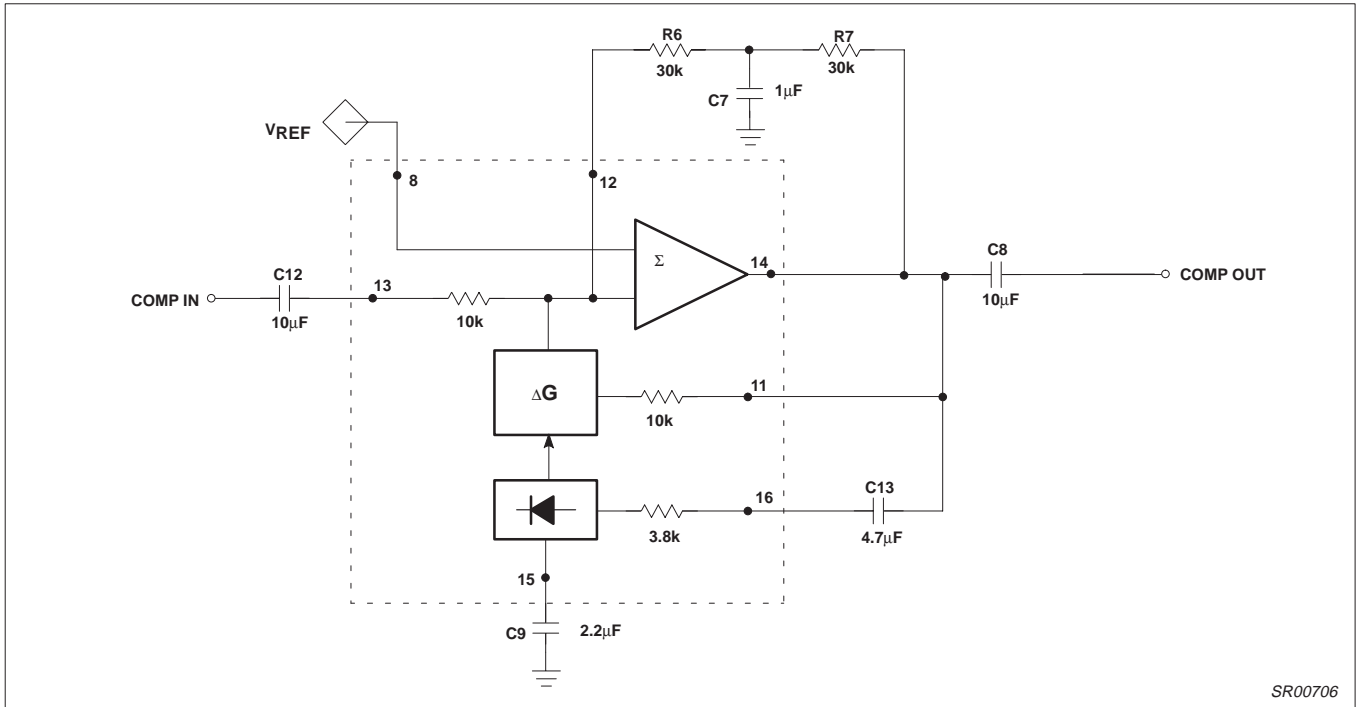

Figure 4. Typical Compressor Configuration

SR00706

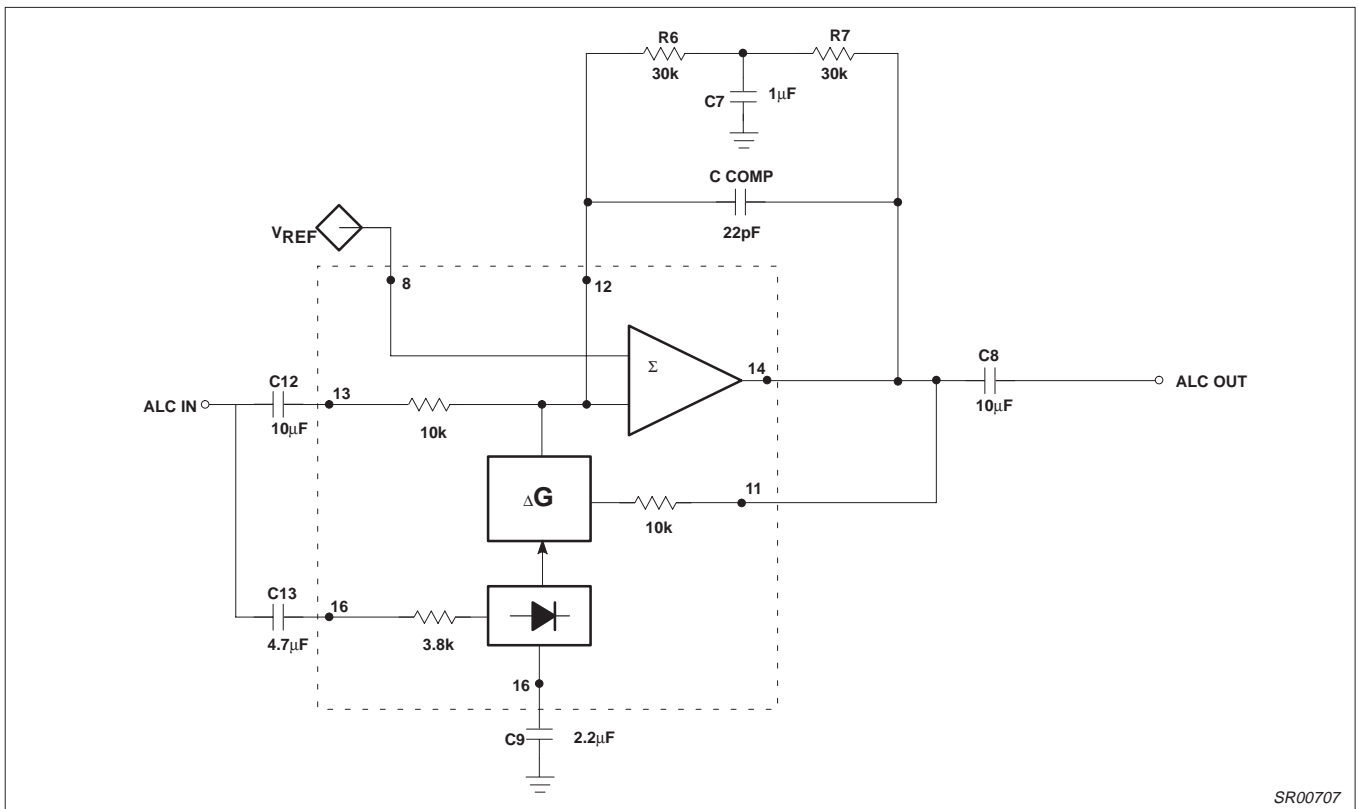

Figure 5. Typical ALC Configuration

SR00707

Low voltage compandor

SA575

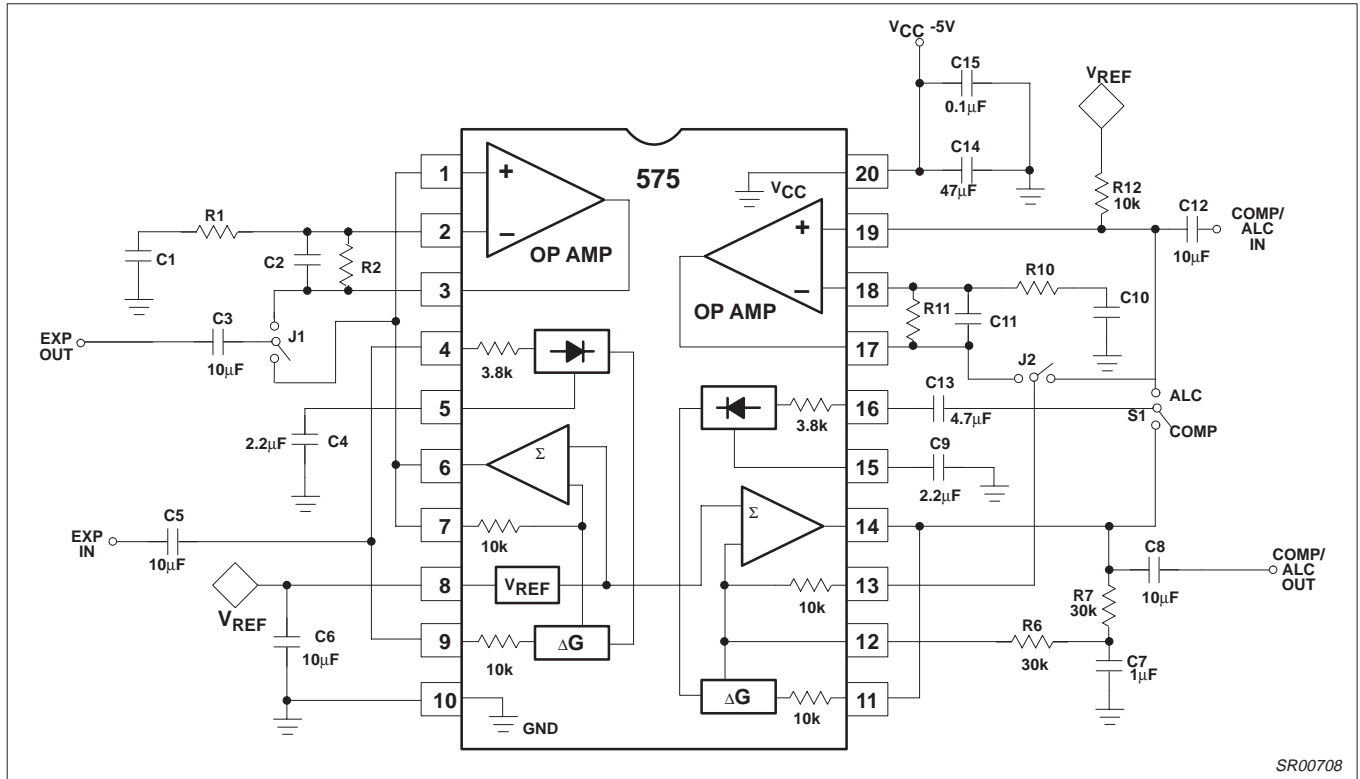
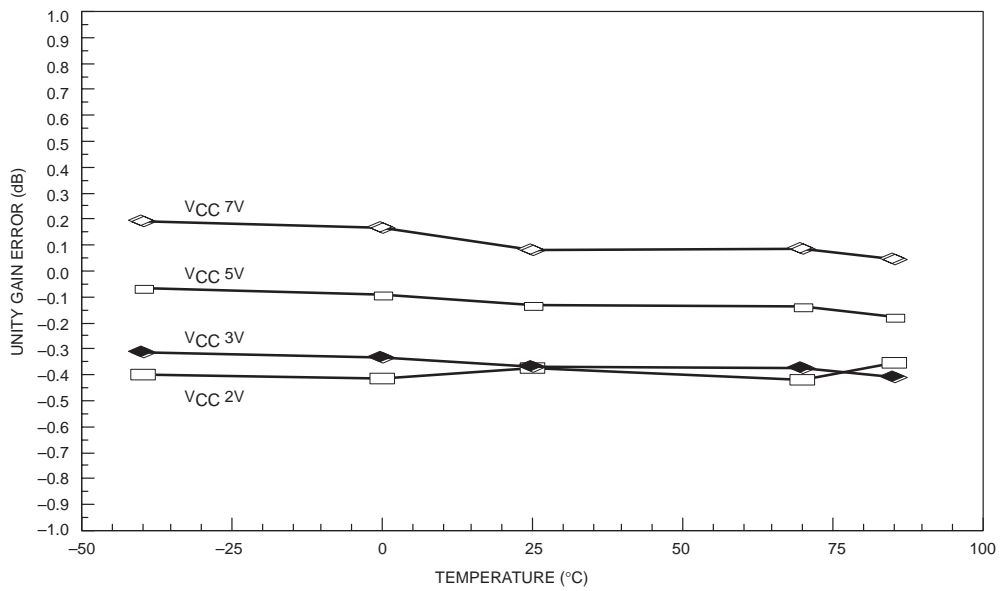

Figure 6. SA575 Low Voltage Expander/Compressor/ALC Demo Board

SR00708

Low voltage compandor

SA575



a. Unity Gain Error vs Temperature and V_{CC}

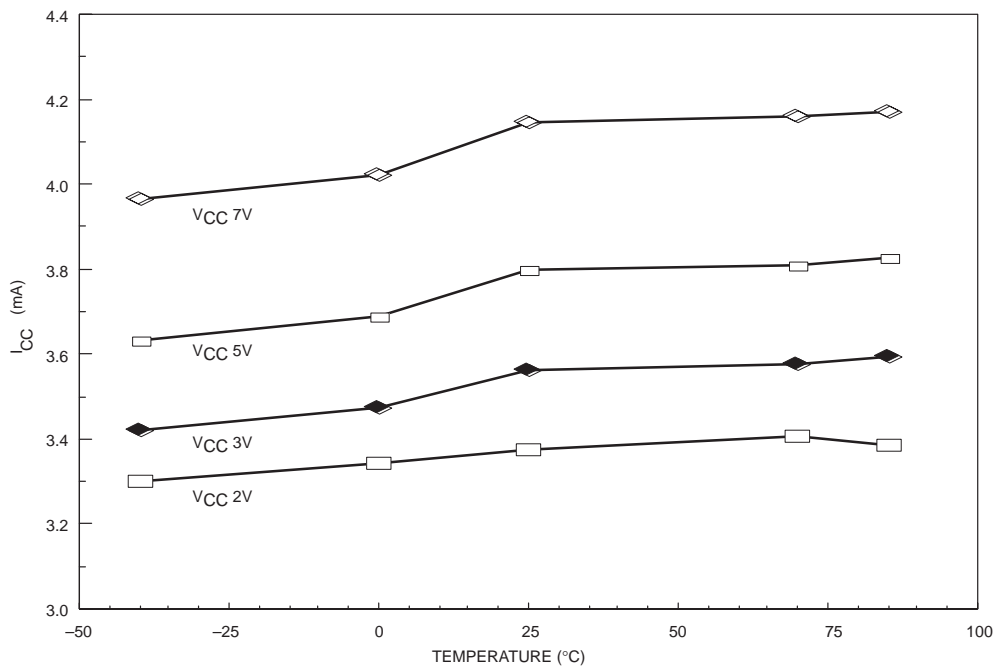

b. I_{CC} vs Temperature and V_{CC}

SR00709

Figure 7. Temperature and V_{CC} Curves

Low voltage compandor

SA575

TYPICAL PERFORMANCE CHARACTERISTICS

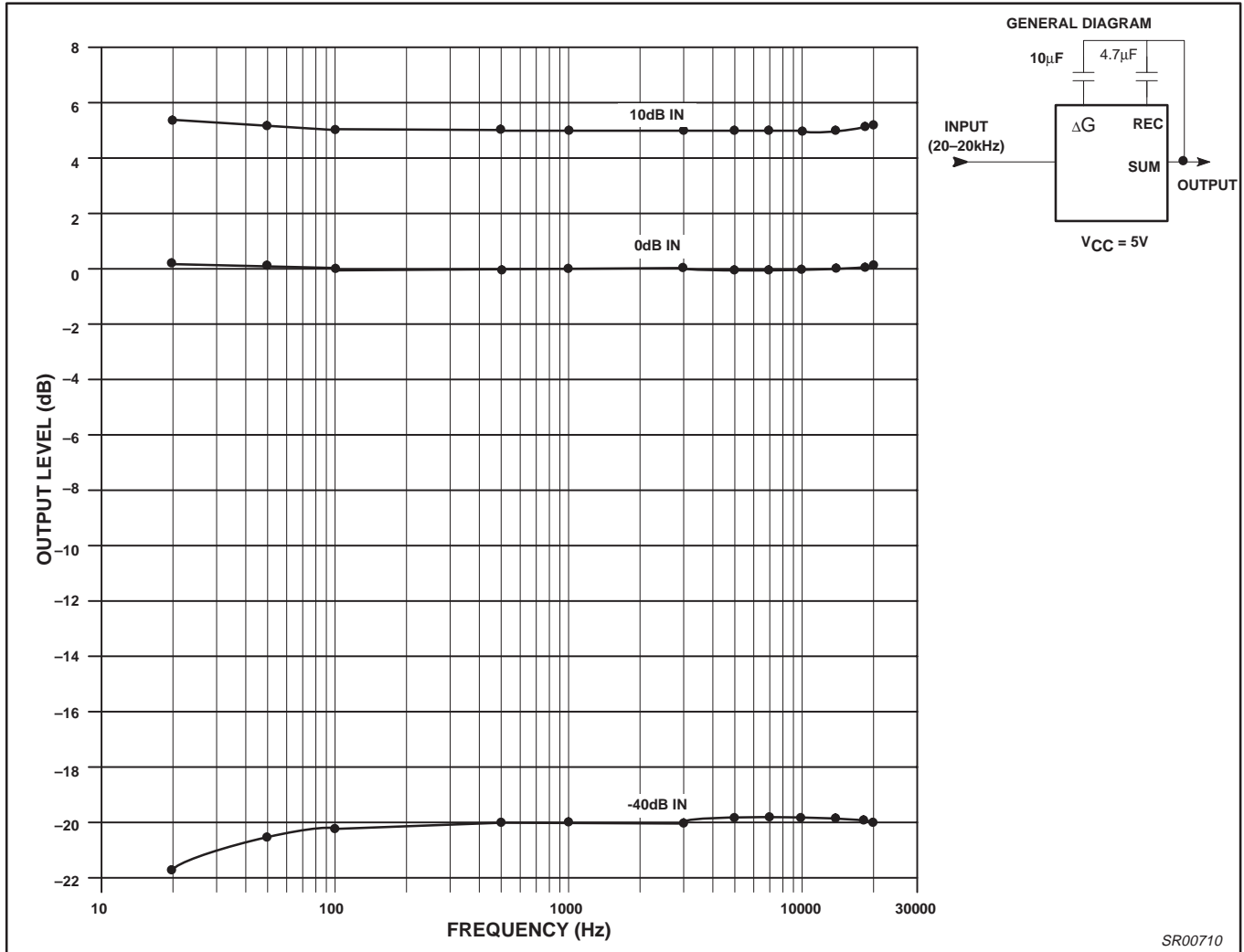

Figure 8. Compressor Output Frequency Response

Low voltage compandor

SA575

TYPICAL PERFORMANCE CHARACTERISTICS (continued)

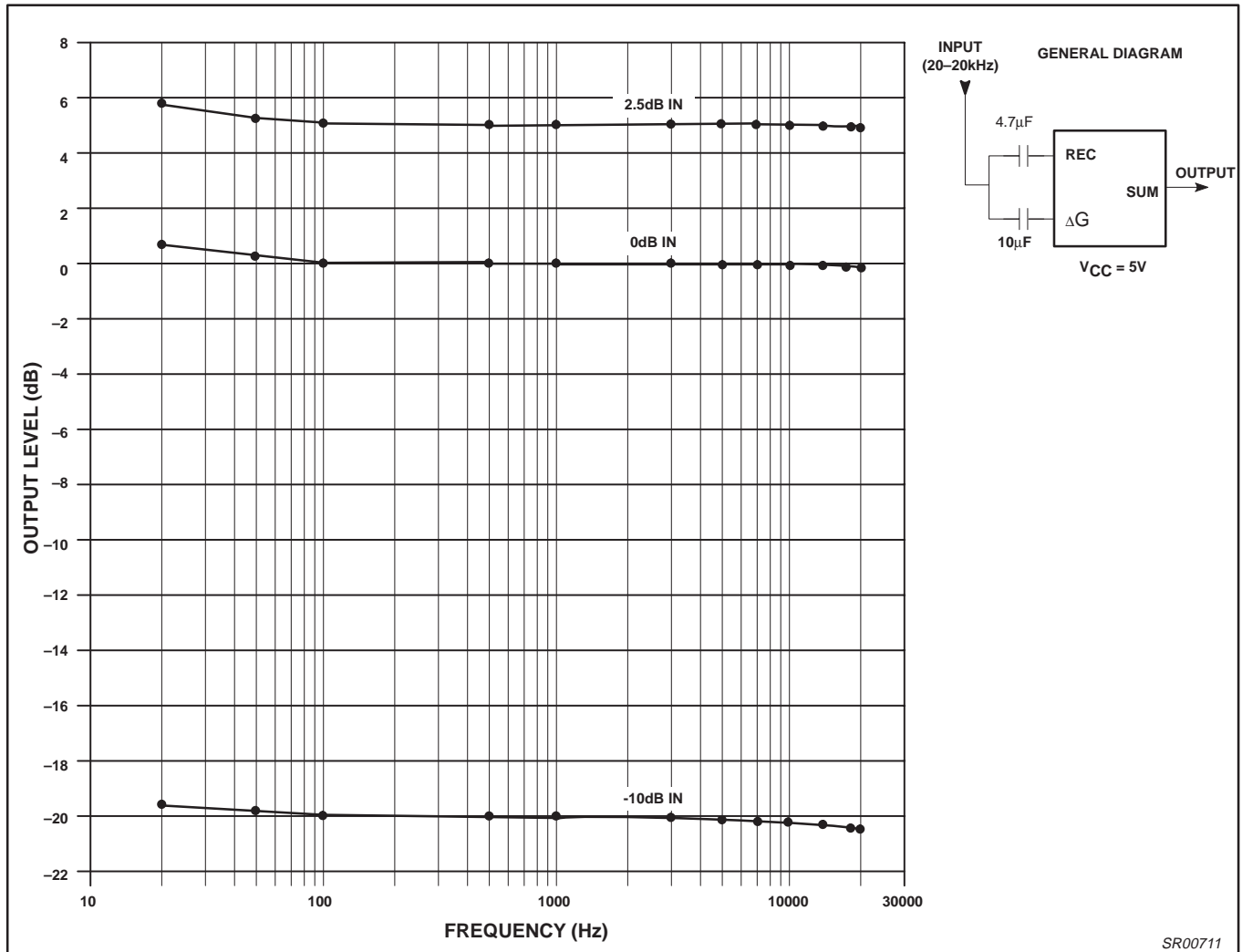

Figure 9. Expander Output Frequency Response

SR00711

Low voltage compandor

SA575

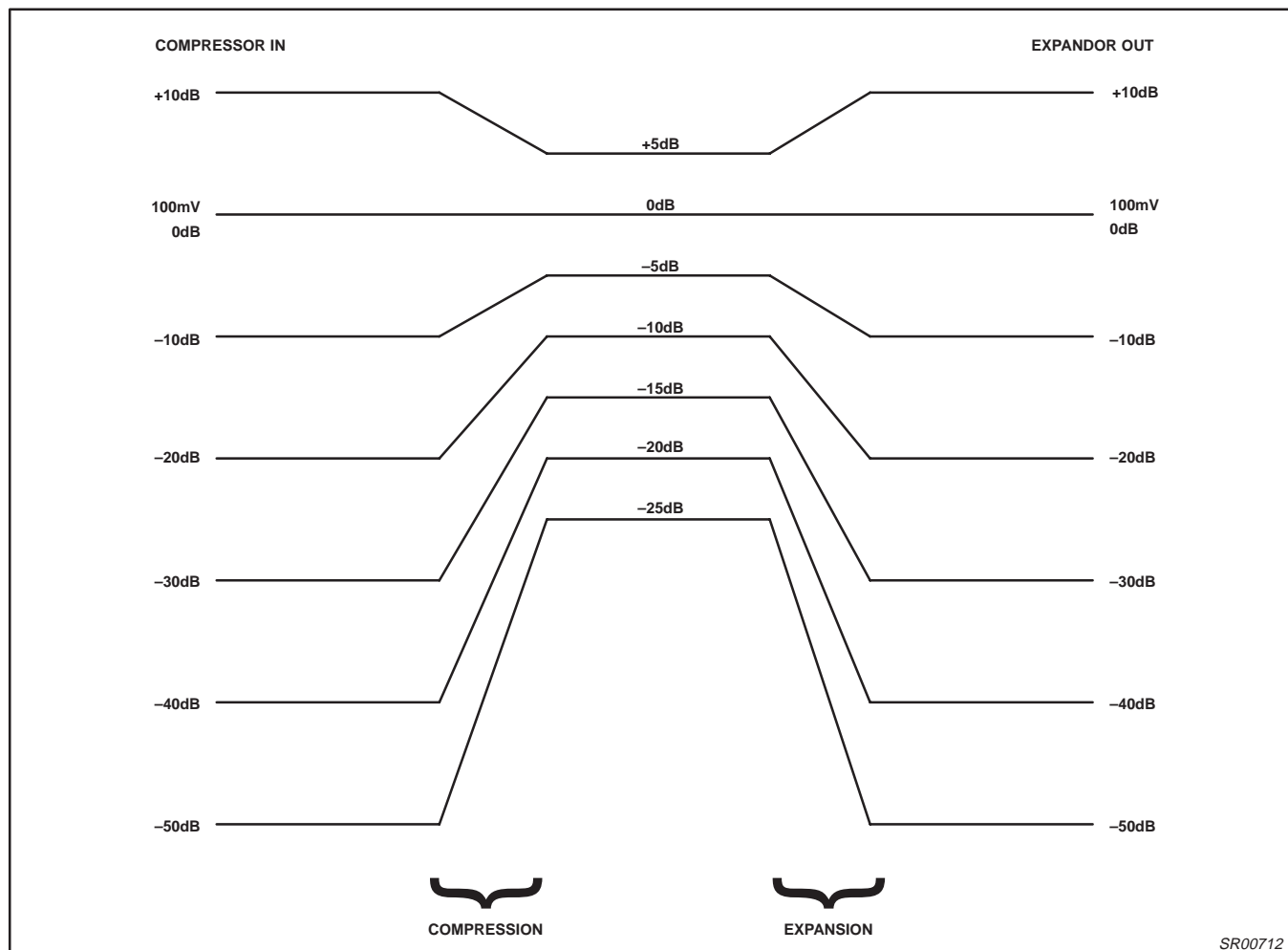

Figure 10. The Companding Function

SR00712

Low voltage compandor

SA575

SO20: plastic small outline package; 20 leads; body width 7.5 mm

SOT163-1

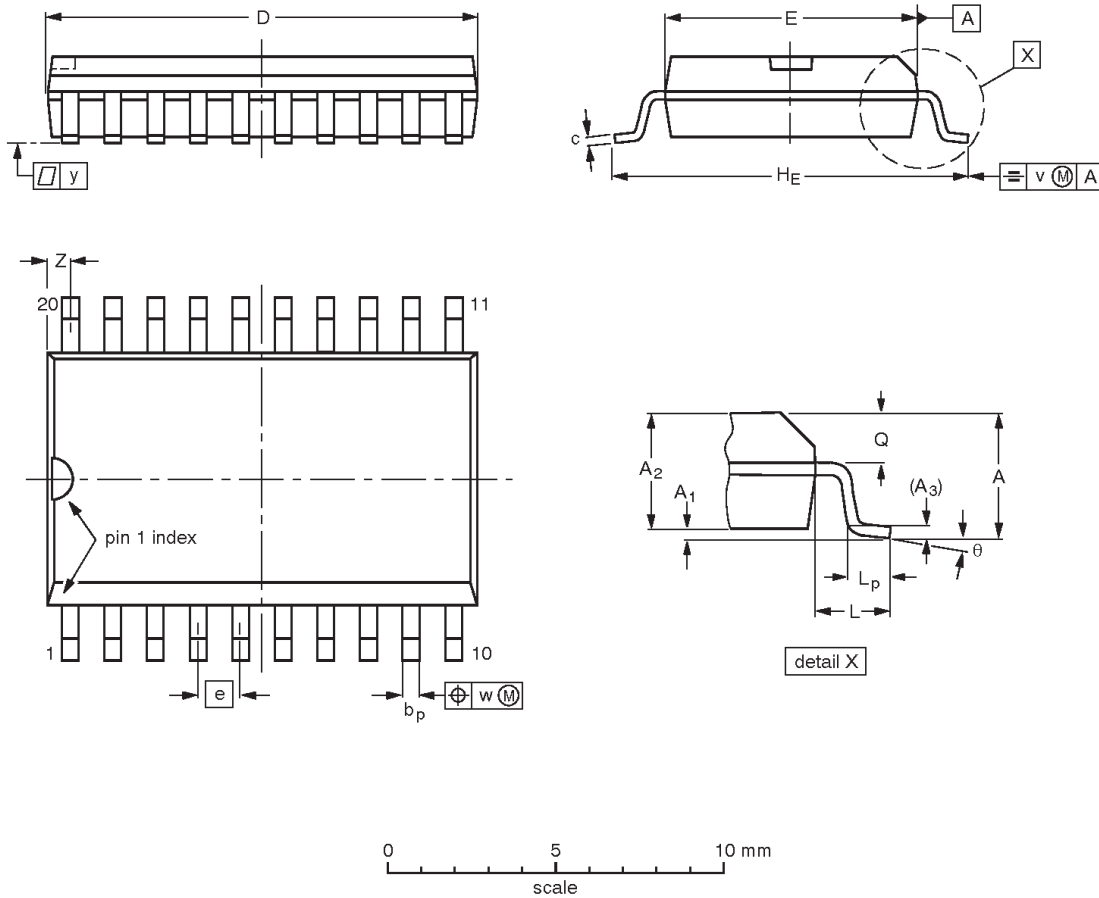

DIMENSIONS (inch dimensions are derived from the original mm dimensions)

UNIT	A max.	A ₁	A ₂	A ₃	b _p	c	D ⁽¹⁾	E ⁽¹⁾	e	H _E	L	L _p	Q	v	w	y	Z ⁽¹⁾	θ
mm	2.65	0.30 0.10	2.45 2.25	0.25	0.49 0.36	0.32 0.23	13.0 12.6	7.6 7.4	1.27	10.65 10.00	1.4	1.1 0.4	1.1 1.0	0.25	0.25	0.1	0.9 0.4	8° 0°
inches	0.10	0.012 0.004	0.096 0.089	0.01	0.019 0.014	0.013 0.009	0.51 0.49	0.30 0.29	0.050	0.42 0.39	0.055	0.043 0.016	0.043 0.039	0.01	0.01	0.004	0.035 0.016	

Note

1. Plastic or metal protrusions of 0.15 mm maximum per side are not included.

OUTLINE VERSION	REFERENCES				EUROPEAN PROJECTION	ISSUE DATE
	IEC	JEDEC	EIAJ			
SOT163-1	075E04	MS-013AC				92-11-17 95-01-24

Low voltage compandor

SA575

SSOP20: plastic shrink small outline package; 20 leads; body width 4.4 mm

SOT266-1

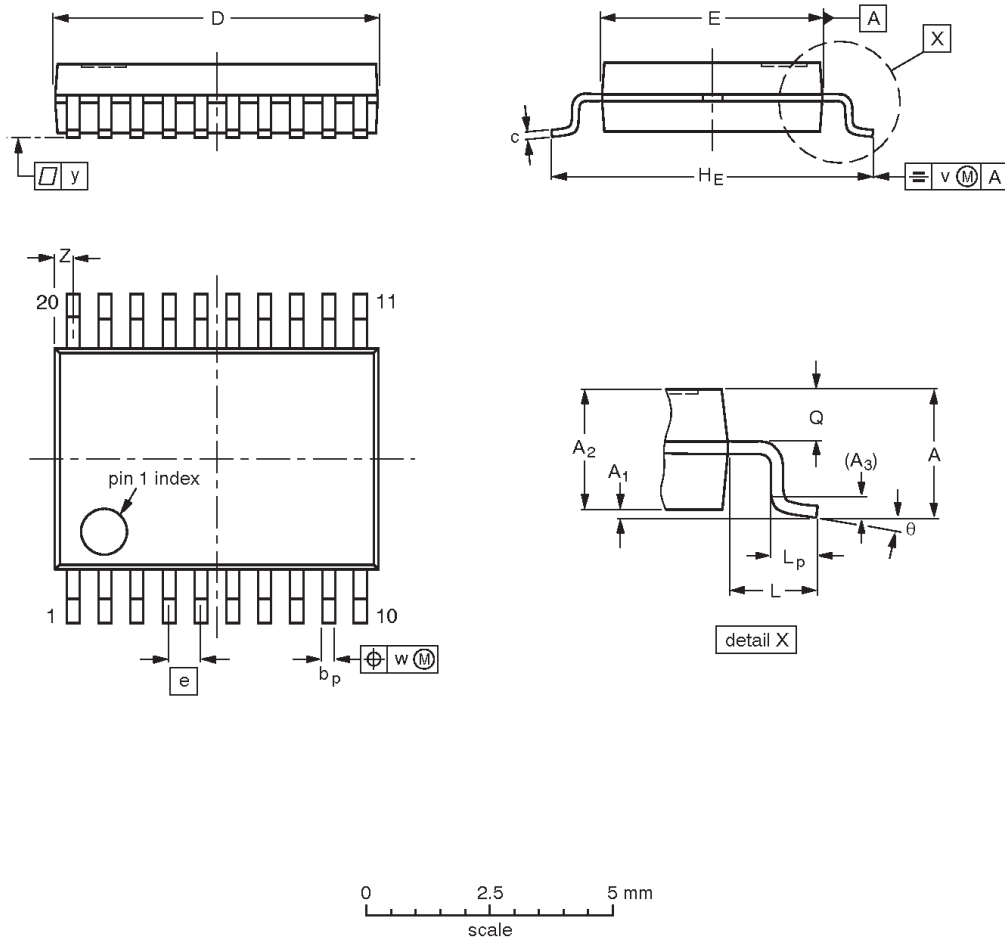

DIMENSIONS (mm are the original dimensions)

UNIT	A max.	A ₁	A ₂	A ₃	b _p	c	D ⁽¹⁾	E ⁽¹⁾	e	H _E	L	L _p	Q	v	w	y	Z ⁽¹⁾	θ
mm	1.5	0.15 0	1.4 1.2	0.25	0.32 0.20	0.20 0.13	6.6 6.4	4.5 4.3	0.65	6.6 6.2	1.0	0.75 0.45	0.65 0.45	0.2	0.13	0.1	0.48 0.18	10° 0°

Note

1. Plastic or metal protrusions of 0.20 mm maximum per side are not included.

OUTLINE VERSION	REFERENCES				EUROPEAN PROJECTION	ISSUE DATE
	IEC	JEDEC	EIAJ			
SOT266-1						90-04-05 95-02-25

Low voltage compandor

SA575

DEFINITIONS

Data Sheet Identification	Product Status	Definition
<i>Objective Specification</i>	Formative or in Design	This data sheet contains the design target or goal specifications for product development. Specifications may change in any manner without notice.
<i>Preliminary Specification</i>	Preproduction Product	This data sheet contains preliminary data, and supplementary data will be published at a later date. Philips Semiconductors reserves the right to make changes at any time without notice in order to improve design and supply the best possible product.
<i>Product Specification</i>	Full Production	This data sheet contains Final Specifications. Philips Semiconductors reserves the right to make changes at any time without notice, in order to improve design and supply the best possible product.

Philips Semiconductors and Philips Electronics North America Corporation reserve the right to make changes, without notice, in the products, including circuits, standard cells, and/or software, described or contained herein in order to improve design and/or performance. Philips Semiconductors assumes no responsibility or liability for the use of any of these products, conveys no license or title under any patent, copyright, or mask work right to these products, and makes no representations or warranties that these products are free from patent, copyright, or mask work right infringement, unless otherwise specified. Applications that are described herein for any of these products are for illustrative purposes only. Philips Semiconductors makes no representation or warranty that such applications will be suitable for the specified use without further testing or modification.

LIFE SUPPORT APPLICATIONS

Philips Semiconductors and Philips Electronics North America Corporation Products are not designed for use in life support appliances, devices, or systems where malfunction of a Philips Semiconductors and Philips Electronics North America Corporation Product can reasonably be expected to result in a personal injury. Philips Semiconductors and Philips Electronics North America Corporation customers using or selling Philips Semiconductors and Philips Electronics North America Corporation Products for use in such applications do so at their own risk and agree to fully indemnify Philips Semiconductors and Philips Electronics North America Corporation for any damages resulting from such improper use or sale.

Philips Semiconductors
811 East Arques Avenue
P.O. Box 3409
Sunnyvale, California 94088-3409
Telephone 800-234-7381

© Copyright Philips Electronics North America Corporation 1997
 All rights reserved. Printed in U.S.A.

Let's make things better.