

# DATA SHEET

## **SAA4996H**

**Motion Adaptive Colour Plus And  
Control IC (MACPACIC) for  
PALplus**

Preliminary specification  
File under Integrated Circuits, IC02

1996 Oct 28

# Motion Adaptive Colour Plus And Control IC (MACPACIC) for PALplus

## SAA4996H

<b>CONTENTS</b>	<b>8</b>	<b>TEST</b>
1	FEATURES	8.1
2	GENERAL DESCRIPTION	8.1.1
3	QUICK REFERENCE DATA	9
4	ORDERING INFORMATION	10
5	BLOCK DIAGRAMS	10.1
6	PINNING	11
7	FUNCTIONAL DESCRIPTION	12
7.1	Introduction	13
7.1.1	Data processing	13.1
7.1.2	Control	13.2
7.2	General requirements	13.3
7.3	Hardware configurations and delays	13.4
7.3.1	Full PALplus module (see Fig.5)	14
7.3.2	Stand-alone MACPACIC (see Fig.6)	15
7.4	Analog processing in front of the PALplus module	
7.5	Block diagram	
7.6	Luminance and helper processing	
7.6.1	Input range	
7.7	Luminance processing	
7.7.1	Luminance helper processing	
7.8	Output signals	
7.9	Measurements	
7.9.1	Line 22 offset reference measurement	
7.9.2	Line 23 and 623 amplitude reference measurement	
7.9.3	Noise measurement in line 23 and 623	
7.10	Automatic gain and offset control	
7.10.1	SNERT control bits influencing the AGC and AOC	
7.10.2	Gain control	
7.10.3	Offset control	
7.10.4	Helper amplitude and bandwidth control	
7.11	Output range	
7.12	Chrominance	
7.12.1	Input range	
7.12.2	Chrominance processing	
7.12.3	Output signals	
7.12.4	Output range	
7.13	Chrominance motion detection	
7.14	Intelligent residual cross-luminance reduction (IRXR)	
7.15	Control	
7.15.1	Input reference signals	
7.15.2	Functional description	
7.15.3	SNERT interface (see application note AN95XXX)	

# Motion Adaptive Colour Plus And Control IC (MACPACIC) for PALplus

SAA4996H

## 1 FEATURES

- Motion adaptive colour plus decoding
- Helper AGC/AOC
- Helper decompanding
- Memory controlling
- VERIC controlling.

The integrated circuit is especially designed to be used in conjunction with the SAA4997H Vertical Reconstruction IC (VERIC) to decode the transmitted PALplus video signals in PALplus colour TV receivers.

In addition, a hardware configuration 'stand-alone MACPACIC' with only two field memories (FM1 and FM4) is also possible. In this condition no helper lines are processed and no vertical reconstruction is applied. This configuration enables the Motion Adaptive Colour Plus processing to be performed in non PALplus receivers.

## 2 GENERAL DESCRIPTION

The SAA4996H (MACPACIC) performs the Motion Adaptive Colour Plus (MACP) processing which is a dedicated field comb filter technique exploited for the PALplus system.

## 3 QUICK REFERENCE DATA

SYMBOL	PARAMETER	MIN.	MAX.	UNIT
$V_{DD}$	digital supply voltage	4.75	5.25	V
$T_{amb}$	operating ambient temperature	0	+70	°C
$T_{die}$	die temperature	–	+125	°C

## 4 ORDERING INFORMATION

TYPE NUMBER	PACKAGE		
	NAME	DESCRIPTION	VERSION
SAA4996H	QFP100	plastic quad flat package; 100 leads (lead length 1.95 mm); body 14 × 20 × 2.7 mm; high stand-off height	SOT317-1

# Motion Adaptive Colour Plus And Control IC (MACPACIC) for PALplus

SAA4996H

## 5 BLOCK DIAGRAMS

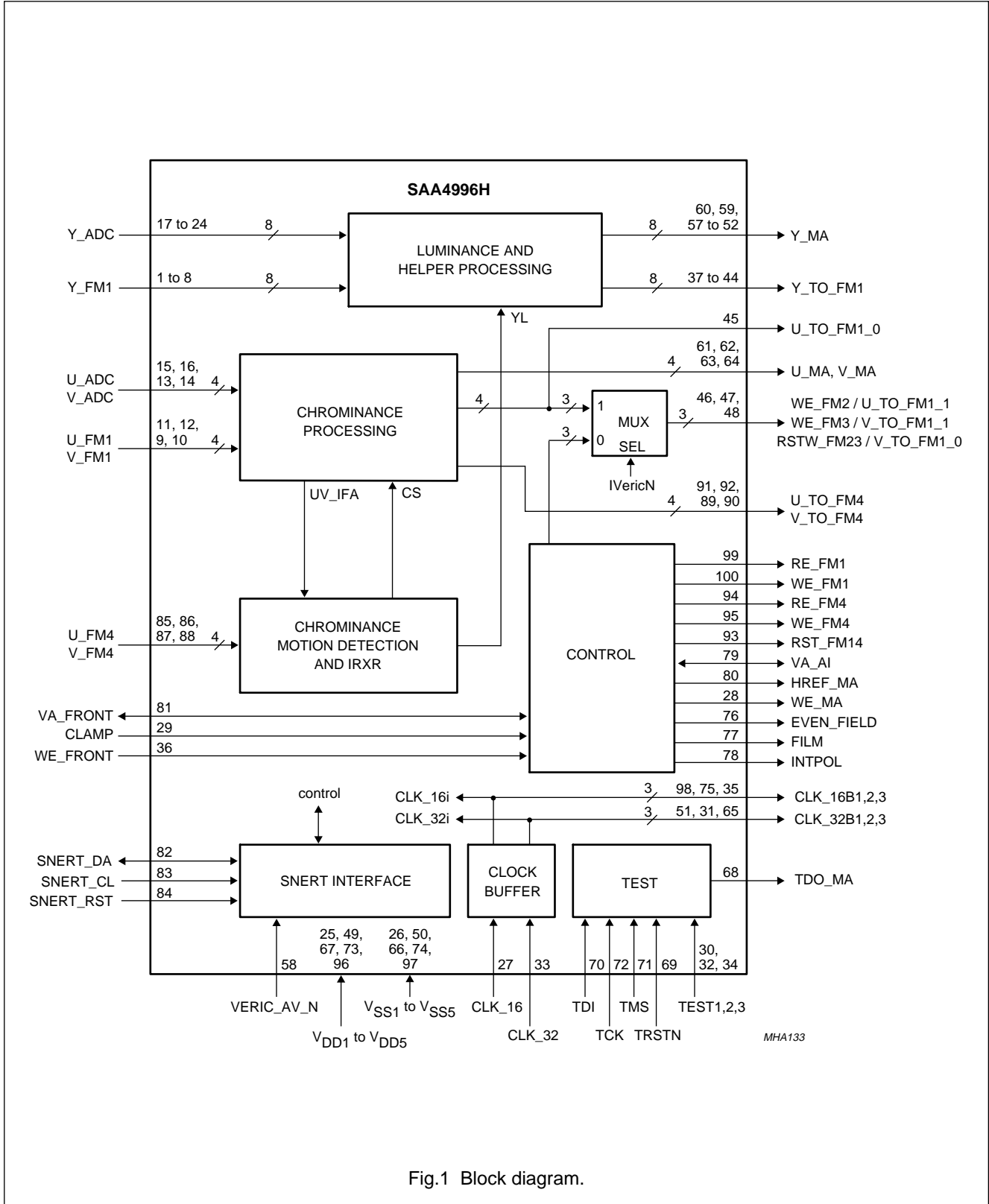

Fig.1 Block diagram.

# Motion Adaptive Colour Plus And Control IC (MACPACIC) for PALplus

SAA4996H

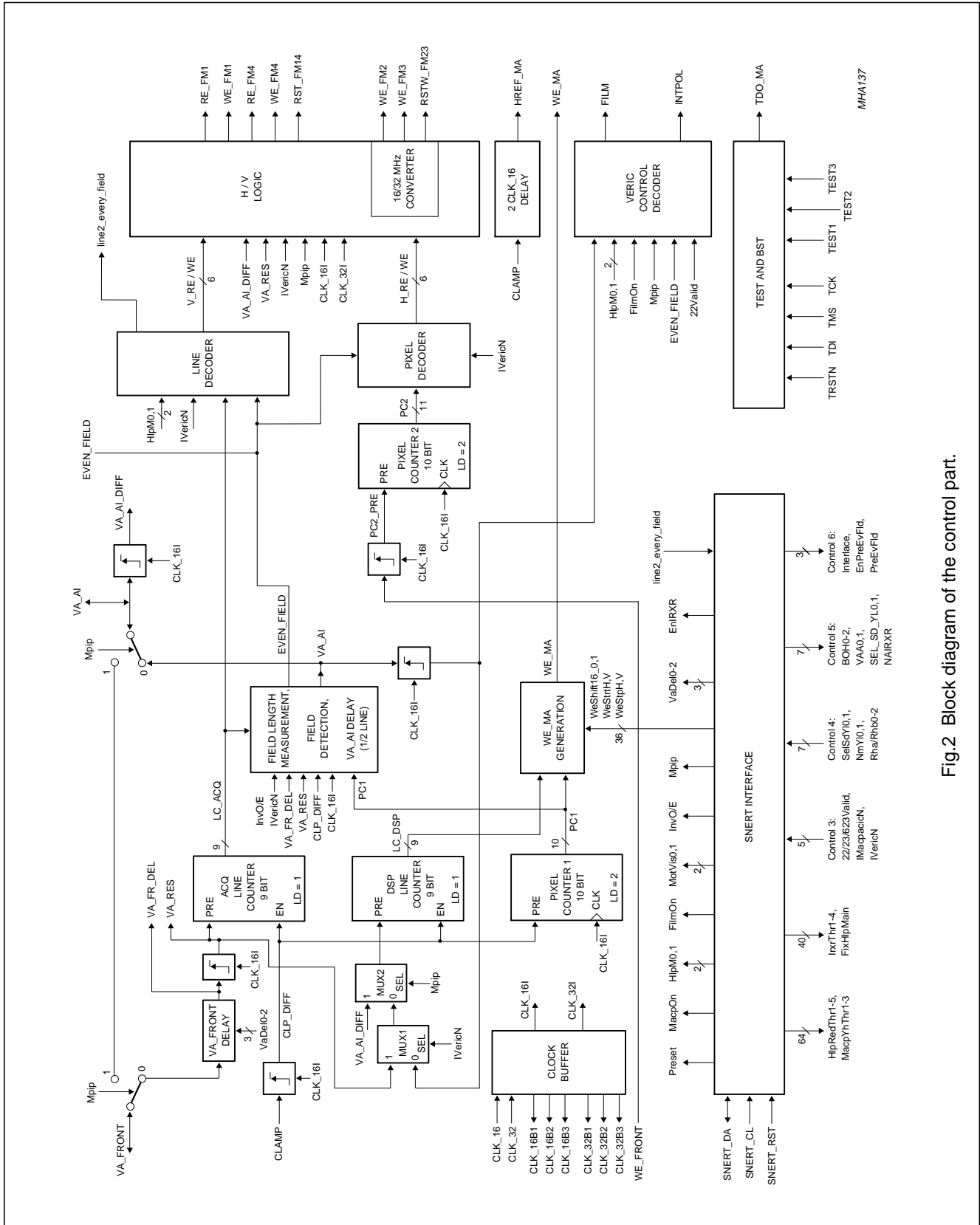

Fig.2 Block diagram of the control part.

# Motion Adaptive Colour Plus And Control IC (MACPACIC) for PALplus

SAA4996H

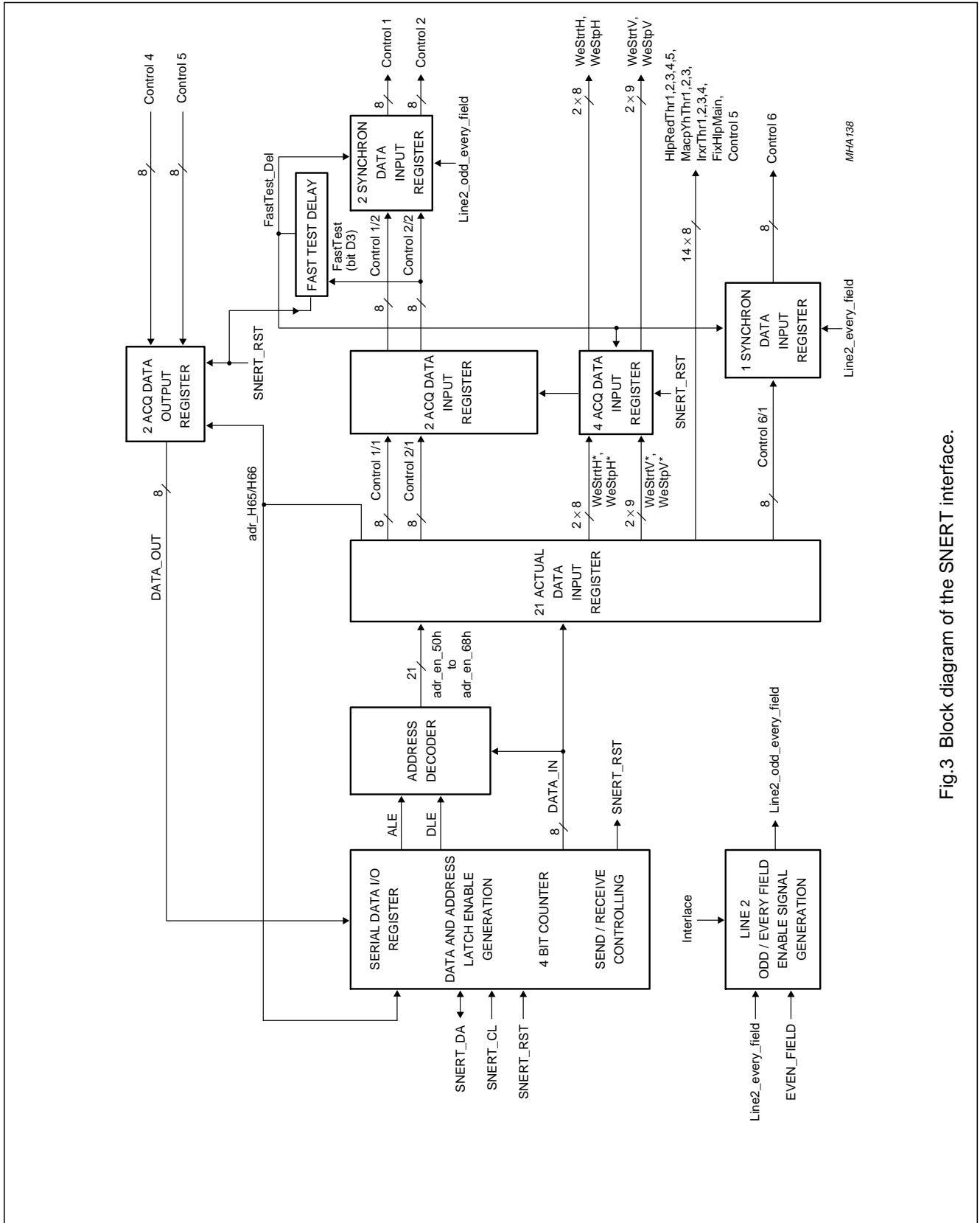

Fig.3 Block diagram of the SNERT interface.

# Motion Adaptive Colour Plus And Control IC (MACPACIC) for PALplus

SAA4996H

## 6 PINNING

SYMBOL	PIN	DESCRIPTION
Y_FM1_7	1	CVBS/helper/luminance input data bit 7 from FM1
Y_FM1_6	2	CVBS/helper/luminance input data bit 6 from FM1
Y_FM1_5	3	CVBS/helper/luminance input data bit 5 from FM1
Y_FM1_4	4	CVBS/helper/luminance input data bit 4 from FM1
Y_FM1_3	5	CVBS/helper/luminance input data bit 3 from FM1
Y_FM1_2	6	CVBS/helper/luminance input data bit 2 from FM1
Y_FM1_1	7	CVBS/helper/luminance input data bit 1 from FM1
Y_FM1_0	8	CVBS/helper/luminance input data bit 0 from FM1
V_FM1_0	9	chrominance input data bit 0 from FM1
V_FM1_1	10	chrominance input data bit 1 from FM1
U_FM1_0	11	chrominance input data bit 0 from FM1
U_FM1_1	12	chrominance input data bit 1 from FM1
V_ADC_0	13	chrominance input data bit 0 from ADC
V_ADC_1	14	chrominance input data bit 1 from ADC
U_ADC_0	15	chrominance input data bit 0 from ADC
U_ADC_1	16	chrominance input data bit 1 from ADC
Y_ADC_0	17	CVBS/helper/luminance data input bit 0 from ADC
Y_ADC_1	18	CVBS/helper/luminance data input bit 1 from ADC
Y_ADC_2	19	CVBS/helper/luminance data input bit 2 from ADC
Y_ADC_3	20	CVBS/helper/luminance data input bit 3 from ADC
Y_ADC_4	21	CVBS/helper/luminance data input bit 4 from ADC
Y_ADC_5	22	CVBS/helper/luminance data input bit 5 from ADC
Y_ADC_6	23	CVBS/helper/luminance data input bit 6 from ADC
Y_ADC_7	24	CVBS/helper/luminance data input bit 7 from ADC
V <sub>DD1</sub>	25	positive supply voltage 1
V <sub>SS1</sub>	26	negative supply voltage 1
CLK_16	27	16 MHz line-locked system clock input pulse
WE_MA	28	write enable output signal; defines active video data
CLAMP	29	horizontal reference input pulse
TEST1	30	test pin 1; must be LOW during normal operation
CLK_32B2	31	32 MHz line-locked clock output pulse
TEST2	32	test pin 2; must be LOW during normal operation
CLK_32	33	32 MHz line-locked system clock input pulse
TEST3	34	test pin 3; must be LOW during normal operation
CLK_16B3	35	16 MHz line-locked clock output pulse
WE_FRONT	36	write enable input signal used as horizontal reference in the event of active data
Y_TO_FM1_0	37	CVBS/helper/luminance output data bit 0 to FM1; stand-alone MACPACIC
Y_TO_FM1_1	38	CVBS/helper/luminance output data bit 1 to FM1; stand-alone MACPACIC
Y_TO_FM1_2	39	CVBS/helper/luminance output data bit 2 to FM1; stand-alone MACPACIC

# Motion Adaptive Colour Plus And Control IC (MACPACIC) for PALplus

SAA4996H

SYMBOL	PIN	DESCRIPTION
Y_TO_FM1_3	40	CVBS/helper/luminance output data bit 3 to FM1; stand-alone MACPACIC
Y_TO_FM1_4	41	CVBS/helper/luminance output data bit 4 to FM1; stand-alone MACPACIC
Y_TO_FM1_5	42	CVBS/helper/luminance output data bit 5 to FM1; stand-alone MACPACIC
Y_TO_FM1_6	43	CVBS/helper/luminance output data bit 6 to FM1; stand-alone MACPACIC
Y_TO_FM1_7	44	CVBS/helper/luminance output data bit 7 to FM1; stand-alone MACPACIC
U_TO_FM1_0	45	chrominance output data to FM1; stand-alone MACPACIC
WE_FM2/U_TO_FM1_1	46	for full PALplus module; write enable for FM2 for stand-alone MACPACIC; chrominance output to FM1
RSTW_FM23/V_TO_FM1_0	47	for full PALplus module; reset write for FM2/FM3 for stand-alone MACPACIC; chrominance output to FM1
WE_FM3/V_TO_FM1_1	48	for full PALplus module; write enable for FM3 for stand-alone MACPACIC; chrominance output to FM1
V <sub>DD2</sub>	49	positive supply voltage 2
V <sub>SS2</sub>	50	negative supply voltage 2
CLK_32B1	51	32 MHz line-locked clock output pulse
Y_MA_0	52	luminance output data bit 0 from MACPACIC
Y_MA_1	53	luminance output data bit 1 from MACPACIC
Y_MA_2	54	luminance output data bit 2 from MACPACIC
Y_MA_3	55	luminance output data bit 3 from MACPACIC
Y_MA_4	56	luminance output data bit 4 from MACPACIC
Y_MA_5	57	luminance output data bit 5 from MACPACIC
VERIC_AV_N	58	input configuration signal VERIC available (VERIC_AV_N = 0)
Y_MA_6	59	luminance output data bit 6 from MACPACIC
Y_MA_7	60	luminance output data bit 7 from MACPACIC
U_MA_0	61	chrominance output data bit 0 from MACPACIC
U_MA_1	62	chrominance output data bit 1 from MACPACIC
V_MA_0	63	chrominance output data bit 0 from MACPACIC
V_MA_1	64	chrominance output data bit 1 from MACPACIC
CLK_32B3	65	32 MHz line-locked clock output pulse
V <sub>SS3</sub>	66	negative supply voltage 3
V <sub>DD3</sub>	67	positive supply voltage 3
TDO_MA	68	boundary scan test: data output signal
TRSTN	69	boundary scan test: reset input signal
TDI	70	boundary scan test: data input signal
TMS	71	boundary scan test: multiplexer set input
TCK	72	boundary scan test: clock input signal
V <sub>DD4</sub>	73	positive supply voltage 4
V <sub>SS4</sub>	74	negative supply voltage 4
CLK_16B2	75	16 MHz line-locked clock output pulse
EVEN_FIELD	76	even field =0 = odd input field; even field =1 = even input field



# Motion Adaptive Colour Plus And Control IC (MACPACIC) for PALplus

SAA4996H

SYMBOL	PIN	DESCRIPTION
FILM	77	control output signal to select film or camera mode in VERIC; FILM = 0: camera mode; FILM = 1: film mode; FILM = 1 and INTPOL = 0; bypass mode for MultiPIP
INTPOL	78	INTPOL = 0 = vertical interpolation in the VERIC not active; INTPOL = 1 = vertical interpolation in the VERIC active
VA_AI	79	vertical reference output pulse or vertical reference input pulse in MultiPIP mode
HREF_MA	80	horizontal reference output pulse
VA_FRONT	81	vertical reference input pulse or vertical reference output pulse in MultiPIP mode
SNERT_DA	82	Synchronous No parity Eight bit Reception and Transmission (SNERT)-bus data
SNERT_CL	83	SNERT-bus clock
SNERT_RST	84	SNERT-bus reset
U_FM4_0	85	chrominance input data bit 0 from FM4
U_FM4_1	86	chrominance input data bit 1 from FM4
V_FM4_0	87	chrominance input data bit 0 from FM4
V_FM4_1	88	chrominance input data bit 1 from FM4
V_TO_FM4_1	89	chrominance output data bit 1 to FM4
V_TO_FM4_0	90	chrominance output data bit 0 to FM4
U_TO_FM4_1	91	chrominance output data bit 1 to FM4
U_TO_FM4_0	92	chrominance output data bit 0 to FM4
RST_FM14	93	reset read/write FM1 and FM4 output
RE_FM4	94	read enable FM4 output
WE_FM4	95	write enable FM4 output
V <sub>DD5</sub>	96	positive supply voltage 5
V <sub>SS5</sub>	97	negative supply voltage 5
CLK_16B1	98	16 MHz line-locked clock output pulse
RE_FM1	99	read enable FM1 output
WE_FM1	100	write enable FM1 output

Motion Adaptive Colour Plus And Control  
IC (MACPACIC) for PALplus

SAA4996H

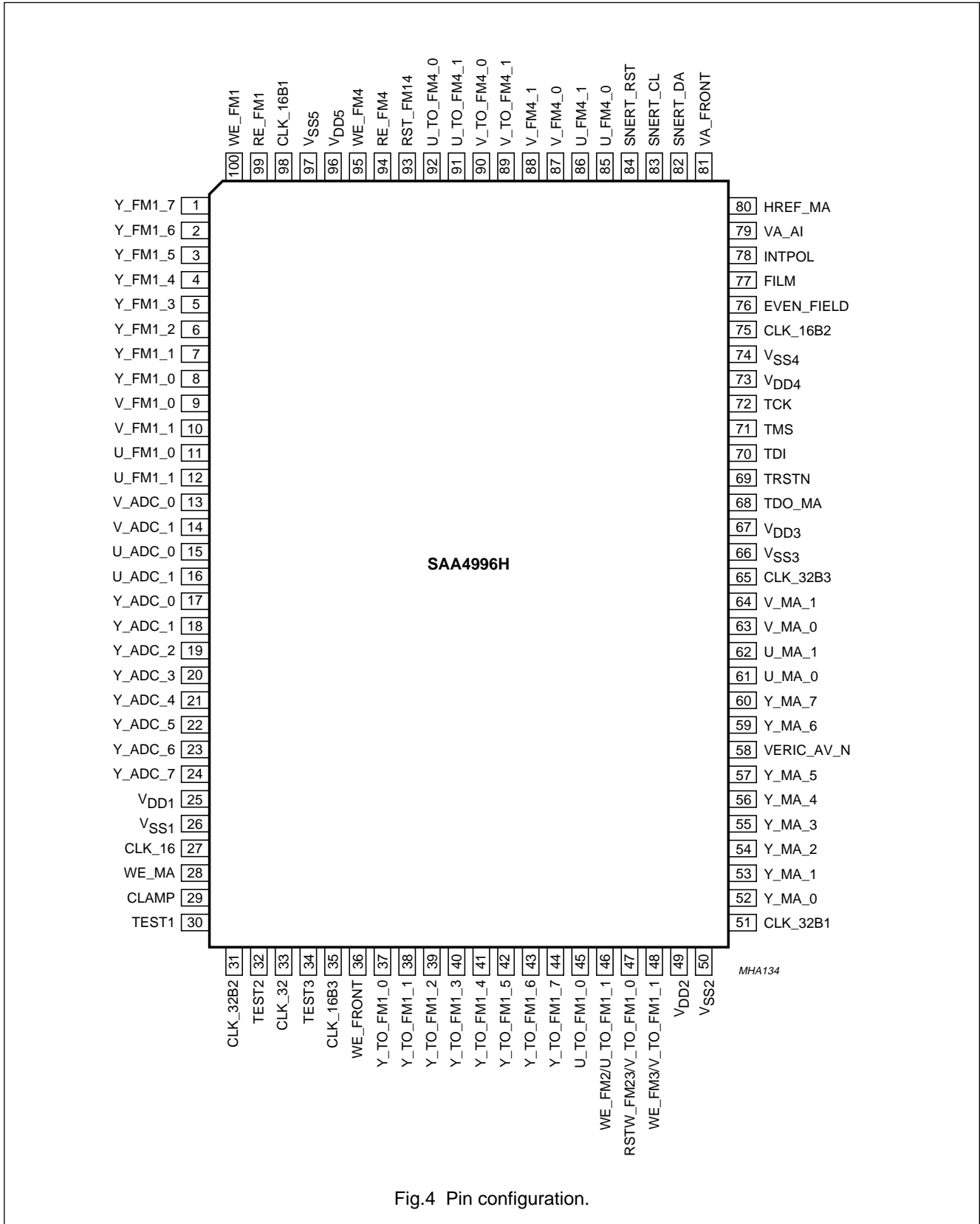

Fig.4 Pin configuration.

# Motion Adaptive Colour Plus And Control IC (MACPACIC) for PALplus

SAA4996H

## 7 FUNCTIONAL DESCRIPTION

### 7.1 Introduction

The MACPACIC is designed to be used in the PALplus decoder module of a PALplus colour TV receiver. The full PALplus decoder module consists of two special integrated circuits and four field memories, as illustrated in Fig.5.

The special ICs are as follows;

- Motion Adaptive Colour Plus And Control IC (MACPACIC) for PALplus (SAA4996H)
- Vertical Reconstruction IC (VERIC) (SAA4997H).

Besides the full PALplus module, a configuration for stand-alone Motion Adaptive Colour Plus processing (MACP) is also possible (see Fig.6). In this event only MACPACIC with FM1 and FM4 are necessary. This configuration enables the MACP processing in non-PALplus receivers to be performed.

The PALplus module is designed to operate in conjunction with a 100 Hz feature box. All special requirements such as the delay of the PALplus module, bypass modes and generation of the necessary control and clock signals will be fulfilled.

#### 7.1.1 DATA PROCESSING

The MACPACIC includes the decompanding functions for the helper lines and the motion adaptive luminance/chrominance separation in accordance with the PALplus system description REV. 3.0 with some modifications;

- The system operates at a clock frequency of 16 MHz
- The Y:U:V format is 4:1:1 instead of 4:2:2
- The filter DEC\_MD\_UV\_LPF is not implemented
- If noisy helper signals are received, the helper bandwidth and/or amplitude can be reduced
- Automatic gain control of the helper signal with respect to the luminance signal.

The input signals are the BB(helper)/CVBS and chrominance signals which are derived from the analog-to-digital converter (ADC).

At its outputs the MACPACIC delivers separate luminance and chrominance signals, each one free from cross-artefacts as main signal, as well as decompanded and filtered helper signals. For standard input signals and, in the event of MultiPIP mode with the help of a PIP module, the MACPACIC can be switched to different bypass modes.

#### 7.1.2 CONTROL

Memory control, PALplus system controlling and clock generation (from the incoming 16 MHz and 32 MHz line-locked clocks) are implemented in the MACPACIC. All clocks and control signals necessary for the PALplus module (excluding read control of FM2/FM3) are generated in the controller part. Inputs are reference signals, clocks and control signals delivered by the colour/helper decoder IC (TDA9144), and the 100 Hz memory controller, i.e. ECO4 (SAA4952) or ECOBENDIC (SAA4970). The MACPACIC also receives control information via a three-wire serial interface (SNERT-bus) from the microprocessor in the 100 Hz feature box.

### 7.2 General requirements

The PALplus IC set is designed to operate in conjunction with the PHILIPS 100 Hz feature box. All requirements with respect to this combination are fulfilled.

The special requirements are as follows;

- The signal processing is adapted to the analog preprocessing in the TDA9144 for luminance, helper and chrominance signals
- Clock rate and clock generation
- Some special control signals are generated in the PALplus module
- The field length must be measured and used to set the delay of the full PALplus module to 1.5 fields
- A SNERT interface is used to transfer control data to and from the PALplus module
- MultiPIP with the help of a PIP module is possible
- Results of noise measurements influence the helper processing
- Automatic gain and offset control is implemented
- Reference signals in line 22 are used for inverse set-up operation
- Noise measurement implemented
- Boundary scan test implemented
- Preset of internal recursive parts for testing.

---

## Motion Adaptive Colour Plus And Control IC (MACPACIC) for PALplus

---

SAA4996H

### 7.3 Hardware configurations and delays

Two general hardware configurations are possible.

#### 7.3.1 FULL PALPLUS MODULE (see Fig.5)

The delay from input to output is 1.5 fields rounded to complete lines, also in the bypass mode. Therefore, the number of input lines of the odd and even fields must be measured. The result of this measurement is then used to generate the required delay.

In the MultiPIP mode the delay of the full PALplus module is one line.

#### 7.3.2 STAND-ALONE MACPACIC (see Fig.6)

In this situation only the MACPACIC with FM1 and FM4 are necessary. No helper lines are processed and no vertical reconstruction with the VERIC is applied.

The delay from input to output is one field, one line and some clocks of processing delay, this also applies in the bypass mode. In the MultiPIP mode the delay is two clocks (CLK\_16).

### 7.4 Analog processing in front of the PALplus module

In front of the MACPACIC an analog colour/helper decoder (TDA9144) performs the colour and helper demodulation.

Because of the requirement that a standard ADC with **clamping on 16** should be used for CVBS and helper analog-to-digital conversion, a black (letter box lines) and mid grey (helper lines) shift is applied in the colour/helper decoder. For reshifting without errors in the digital domain these shift levels are inserted as a reference in line 22.

In the event of stand-alone MACPACIC and PALplus input signals the helper demodulation must be switched off.

No special actions are taken in the colour/helper decoder for chrominance processing.

In this document U will refer to  $-(B - Y)$  and V will refer to  $-(R - Y)$ .

In combination with the full PALplus module with letter box input signals (16:9), the PAL delay line of the colour/helper decoder must be switched off. This is because this function is also implemented in the vertical reconstruction filter of the VERIC. For all other input signals and for stand-alone MACPACIC the PAL delay line must be switched on.

# Motion Adaptive Colour Plus And Control IC (MACPACIC) for PALplus

## SAA4996H

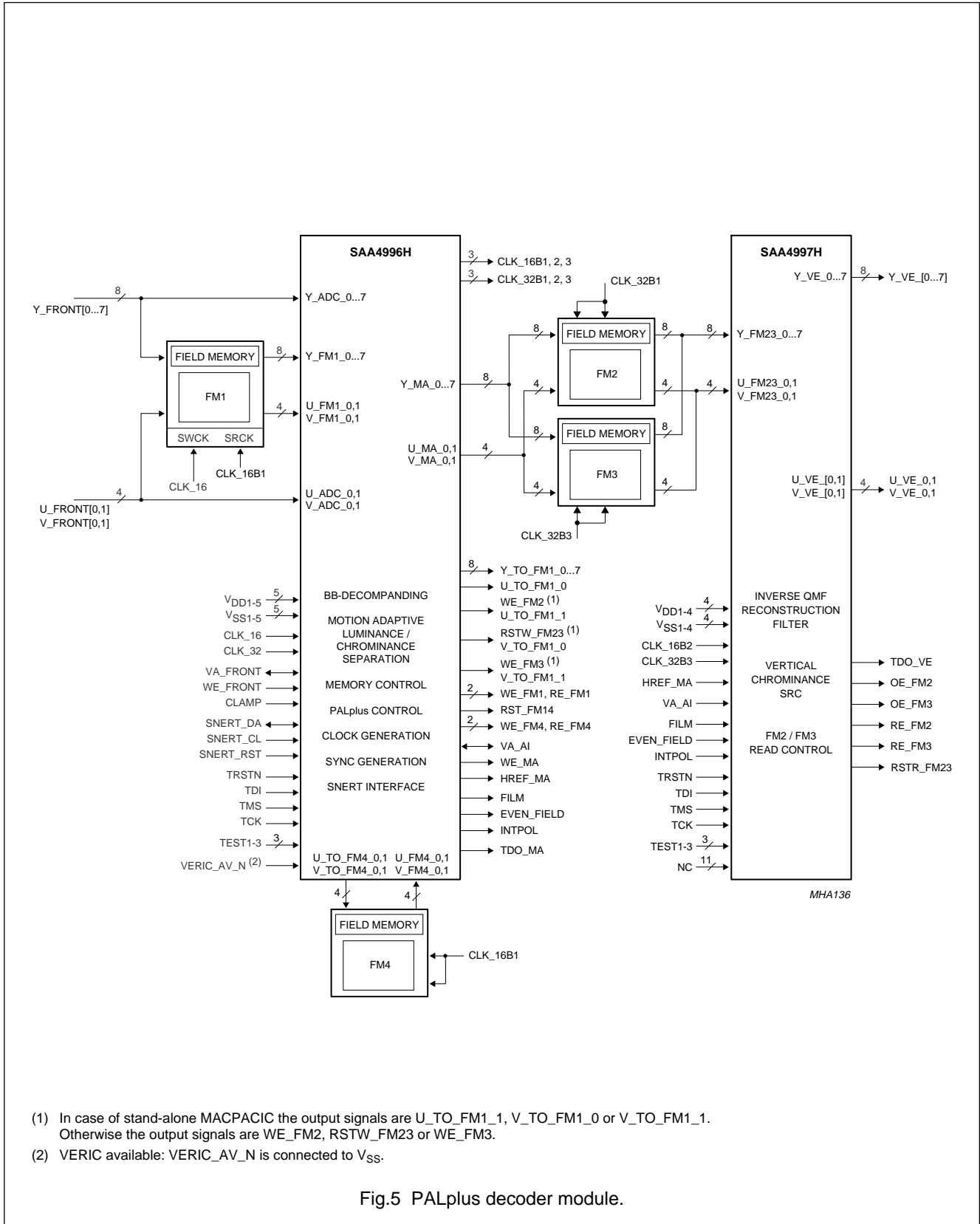

- (1) In case of stand-alone MACPACIC the output signals are U\_TO\_FM1\_1, V\_TO\_FM1\_0 or V\_TO\_FM1\_1. Otherwise the output signals are WE\_FM2, RSTW\_FM23 or WE\_FM3.
- (2) VERIC available: VERIC\_AV\_N is connected to V<sub>SS</sub>.

Fig.5 PALplus decoder module.

# Motion Adaptive Colour Plus And Control IC (MACPACIC) for PALplus

SAA4996H

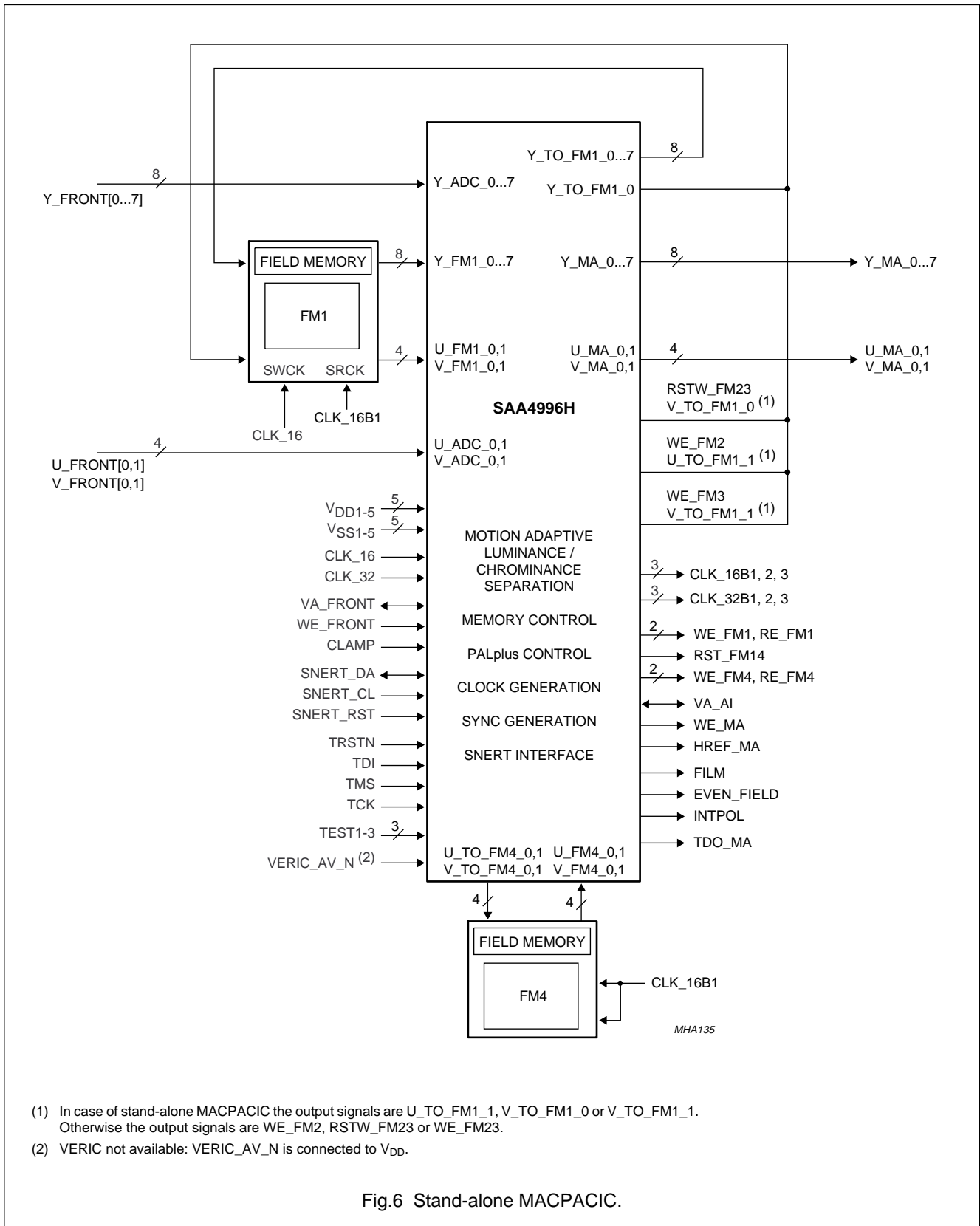

- (1) In case of stand-alone MACPACIC the output signals are U\_TO\_FM1\_1, V\_TO\_FM1\_0 or V\_TO\_FM1\_1. Otherwise the output signals are WE\_FM2, RSTW\_FM23 or WE\_FM23.
- (2) VERIC not available: VERIC\_AV\_N is connected to V<sub>DD</sub>.

Fig.6 Stand-alone MACPACIC.

# Motion Adaptive Colour Plus And Control IC (MACPACIC) for PALplus

SAA4996H

## 7.5 Block diagram

The functional block diagram of the MACPACIC for PALplus is illustrated in Fig.1. The device consists of 4 main parts:

- Luminance and helper processing
- Chrominance processing
- Chrominance motion detection
- Control.

The clock rate of the input data is 16 MHz. Internally, the device operates at a 32 MHz clock frequency. The clock rate of the output data is either 32 MHz (in combination with FM2, FM3 and VERIC) or 16 MHz for stand-alone MACP processing.

The delay of the full PALplus module is 1.5 fields in the PALplus and bypass mode. A field length measurement is implemented. For MultiPIP with the help of a PIP module the delay of the PALplus module is one line.

For stand-alone MACP the delay is one field, one line and some clocks of processing delay.

For MultiPIP with the help of a PIP module the delay of MACPACIC is two clocks (CLK\_16).

## 7.6 Luminance and helper processing

### 7.6.1 INPUT RANGE

To use a standard ADC with **clamping on 16**, a black set-up for the CVBS signal and a black/mid grey set-up for the helper signal has to be performed in the colour/helper decoder. The shift values for black set-up and mid grey set-up are inserted in line 22.

All values are nominal values.

#### CVBS:

- clamp level: 16
- black set-up: 51
- white: 191
- format: 8-bit, straight binary

#### Helper:

- mid grey set-up: 121
- range:  $(121 - 60)$  to  $(121 + 60) = 61$  to 181
- format: 8-bit, offset binary

#### Y (standard input):

- black: 16
- peak white: 191
- format: 8-bit, straight binary

## 7.7 Luminance processing

The luminance and the helper processing have two input branches. One input is an 8-bit wide 16 MHz data stream from the ADC. The other is an 8-bit wide 16 MHz data stream from the field memory (FM1). The odd field of an input frame is stored in the field memory FM1. In the even field of a frame, the even field together with the delayed odd field is processed by the MACPACIC.

To remove the chrominance part of the incoming composite video signal, the Motion Adaptive Colour Plus technique is applied. Colour Plus is a dedicated comb filter technique, which makes full use of the correlation of two successive fields.

During processing the data of the odd and even fields are separated in a high-pass and low-pass part. The high-pass part consists of the luminance high-pass component and the modulated chrominance signal. Due to the phase difference of the colour carrier of  $180^\circ$  from the odd to the even field, the chrominance signal can be removed by adding the high-pass signals.

This processing will work successfully in the film mode, because scanned film material is motionless within the two fields of one frame. In the camera mode a motion detector fades down the luminance high-pass component if motion is detected.

The following vertical low-pass filters perform a vertical interpolation of the high-pass part by the factor of two.

In the event of bad signal conditions, the residual cross-luminance signal, caused by clock jitter between two fields, can be reduced by using this filter as a 2D comb filter. Therefore different sets of coefficients can be selected via SNERT.

The luminance high-pass part and the luminance low-pass part are then added.

The automatic gain control (AGC) and automatic offset control (AOC) functions use reference lines 23, 623 and 22 to reduce errors in the vertical reconstruction in the VERIC. This is to reduce the effects of any errors that might be caused due to variations in the conventional PAL references in the signal during the transmission chain with respect to the levels of the luminance letter box and helper signals.

## Motion Adaptive Colour Plus And Control IC (MACPACIC) for PALplus

SAA4996H

### 7.7.1 LUMINANCE HELPER PROCESSING

In the event of incoming helper, the switchable low-pass filter acts as an inverse shaping and bandwidth reduction filter for the helper lines. If a distorted helper signal is transmitted, the bandwidth can be reduced from 2.2 MHz (0 dB) to 1.0 MHz or to 0.5 MHz (-3 dB).

The high-pass part of the luminance processing is not used for the helper processing.

To stabilize the transmitted helper signal against noise disturbances, the encoder performs a companding of the signal. In the decoder the decompanding is performed in the AGOC block (see Fig.7).

### 7.8 Output signals

In the event of full PALplus configuration, odd and even field data are multiplexed to a 32 MHz data stream.

For the stand-alone MACPACIC, the processed even field data is connected to the field memory FM1 and the odd field data is switched to the output Y\_MA. In the next field the stored even field data is read out of the field memory FM1 and then connected to the output of the MACPACIC.

If MultiPIP mode is selected, the luminance input data from the ADC (Y\_ADC) is switched directly to the output Y\_MA.

In the bypass mode the luminance data processing is switched off and multiplexed data is connected to the MACPACIC output.

The clock frequency of the output data Y\_MA is 32 MHz for the MACPACIC in combination with the VERIC, or 16 MHz for the stand-alone MACPACIC.

### 7.9 Measurements

The digital data stream at the input of the PALplus decoder module contains three reference lines;

- Reference line 22 consists of the black and mid grey set-up, inserted by the colour/helper decoder
- The second half of line 23 contains the black level reference and the maximum negative reference for the PALplus helper lines
- The first half of line 623 contains reference values for the black level and the peak white level for the main lines.

The reference lines 23 and 623 are generated by the PALplus encoder and are used to reduce the effects of any errors that might be caused due to variations in the transmission chain with respect to the levels of the luminance letter box and helper signals.

The content and the timing of the reference lines are illustrated in Figs 13, 14 and 15.

#### 7.9.1 LINE 22 OFFSET REFERENCE MEASUREMENT

Due to the fact that a standard ADC with a clamping level of 16 should be inserted for CVBS and helper analog-to-digital conversion, a black offset for the letter box lines and a mid grey offset for the helper lines are carried out in the colour/helper decoder. These offset values are inserted as references in line 22 to reshift the CVBS and helper signals in the digital domain without errors. Therefore, a measurement of the offsets in line 22 is necessary. The average value of the real offset is calculated from 64 samples and subtracted from the CVBS and helper signal. The CVBS and helper input signal are illustrated in Fig.16.

#### 7.9.2 LINE 23 AND 623 AMPLITUDE REFERENCE MEASUREMENT

The helper and luminance amplitude measurement consists of averaging 64 samples each of;

- Helper zero (MHZ).
- Helper maximum (MHM).
- Luminance black (MLB).
- Luminance white (MLW).

Measured helper amplitude = helper maximum minus helper zero.

Measured luminance amplitude = luminance white minus luminance black.

Frame integration is performed with a feed back factor of  $(1 - K) = 1/16$ . The frame integration part can be preset with the first measured value. Preset is controlled with the preset bit transmitted via SNERT.

#### 7.9.3 NOISE MEASUREMENT IN LINE 23 AND 623

For the helper lines the noise measurement is carried out in reference line 23 and for the letter box lines in reference line 623. Both measurements are active in the black reference levels of line 23 and line 623 respectively.

The processing of the noise measurement for the helper signal and the letter box signal is performed in the same way.

First the average value of 64 samples is calculated. The single actual sample values are subtracted from this average value and the sum of these absolute differences are frame integrated. The integration factor is  $1 - K = 1/16$ .



# Motion Adaptive Colour Plus And Control IC (MACPACIC) for PALplus

SAA4996H

The frame integration part can be preset with the first measured value. Preset is controlled via a bit from the SNERT interface.

## 7.10 Automatic gain and offset control

The automatic gain and offset control circuit evaluates the results of the reference data, which are derived from reference lines 22, 23 and 623 to eliminate any offset and gain differences between the letter box lines and the helper lines. This is caused during transmission of the video signal.

### 7.10.1 SNERT CONTROL BITS INFLUENCING THE AGC AND AOC

MacpOn: If line 22 is not detected this bit will be ignored and the MACP processing (and thus AGC and AOC) is switched off.

FilmOn: If line 22 is not detected, the VERIC operates in Camera mode.

HlpM1, HlpM0: In adaptive and fixed helper processing modes (HlpM1 = 1, HlpM0 = X) AGC and AOC are achieved.

**Table 1** Control bits HlpM1 and HlpM0

HlpM1	HlpM0	FUNCTION
0	0	no helper processing (any aspect ratio, without helper)
0	1	helper set to zero (up-conversion without helper)
1	0	adaptive helper processing (helper processing controlled by reference amplitudes and noise in the helper channel)
1	1	fixed helper processing (fixed gain values loaded via SNERT-bus)

### 7.10.2 GAIN CONTROL

If line 22 reference is present in a frame, the luminance input signal contains black set-up and reduced amplitude. The luminance gain then is 1.25. If line 22 is not valid the luminance gain is 1.0.

The helper gain is controlled by the measured helper amplitude in line 23 to match the helper amplitude to the decompanding table. After decompanding the helper amplitude is controlled by the measured luminance amplitude in line 623, to obtain the correct luminance/helper ratio for the QMF filter in the VERIC.

The helper amplitude is reduced when the measured noise exceeds a certain threshold level. These thresholds are conveyed via the SNERT-bus. The reduction of the helper amplitude, before decompanding, ensures that more noise is cancelled by the coring. The adaptive helper gain control is switched off when the SNERT bits HlpM1 and HlpM0 are both at logic 1. In this condition the helper gain is defined by the values FixHlp and FixMain via the SNERT-bus.

If the measured helper or luminance amplitude is below the threshold level, or when line 22 is not valid, the helper is switched off.

### 7.10.3 OFFSET CONTROL

As long as line 22 reference is present, luminance and helper offset are controlled by line 22. If line 22 is not valid the offset value is **fixed to 16**.

For luminance offset control a hysteresis function, controlled by SNERT, is applied to the measured luminance offset.

### 7.10.4 HELPER AMPLITUDE AND BANDWIDTH CONTROL

In the event of noisy helper signals the helper amplitude and bandwidth can be reduced to avoid disturbances in the inverse QMF processing in VERIC.

Five thresholds are therefore transmitted via SNERT. These thresholds are compared with the measured helper noise value. The results are used to control a state machine with five states.

The state machine is initialized with the preset bit from SNERT or when line 22 is valid for the first time.

The output states are used to control the helper amplitude and bandwidth as shown in Fig.8 and Tables 2 and 3.

## 7.11 Output range

Luminance lines: straight binary, black = 16, white = 191.

PALplus helper lines: offset binary,  $128 \pm 70$ .

# Motion Adaptive Colour Plus And Control IC (MACPACIC) for PALplus

SAA4996H

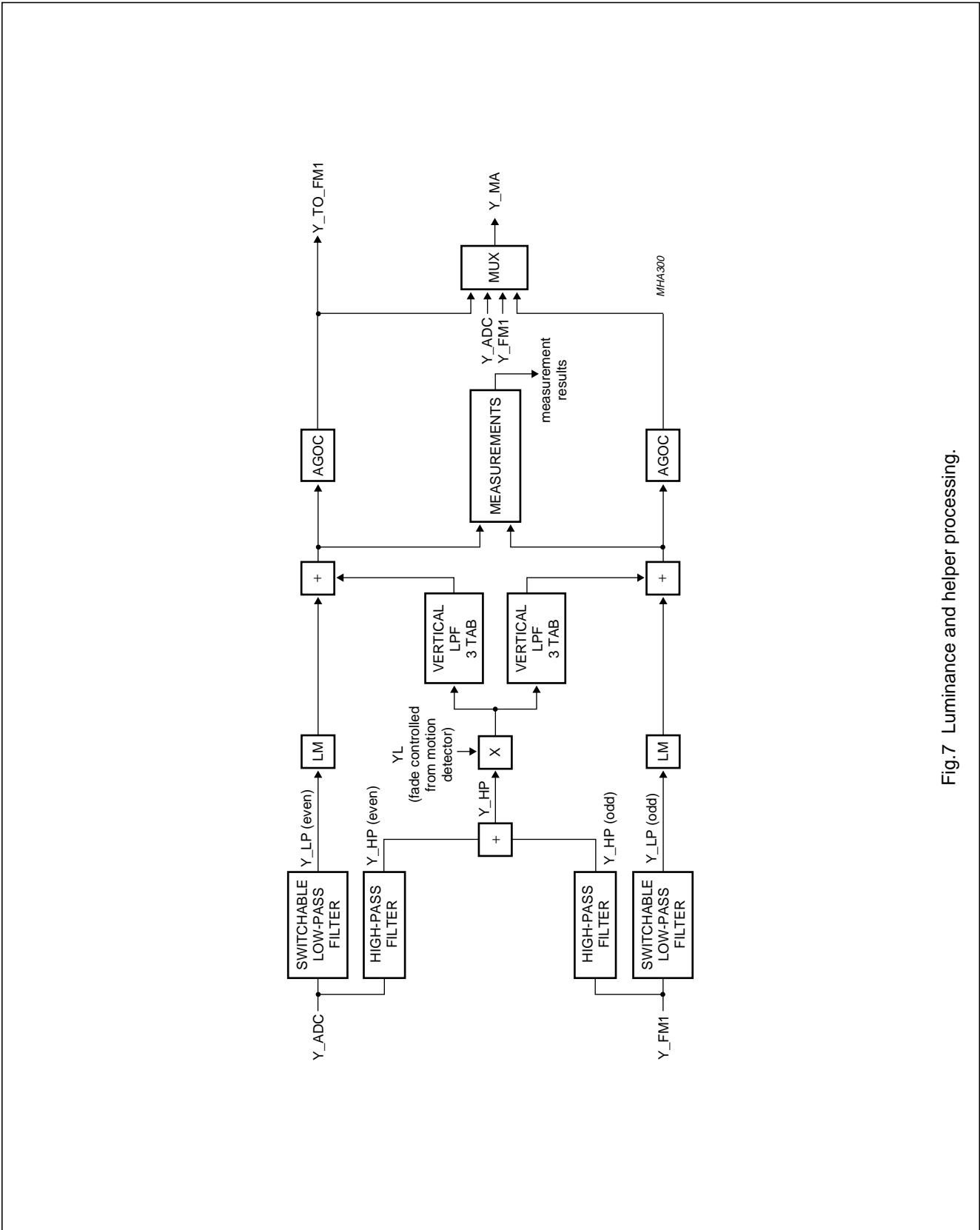

Fig.7 Luminance and helper processing.

Motion Adaptive Colour Plus And Control IC (MACPACIC) for PALplus

SAA4996H

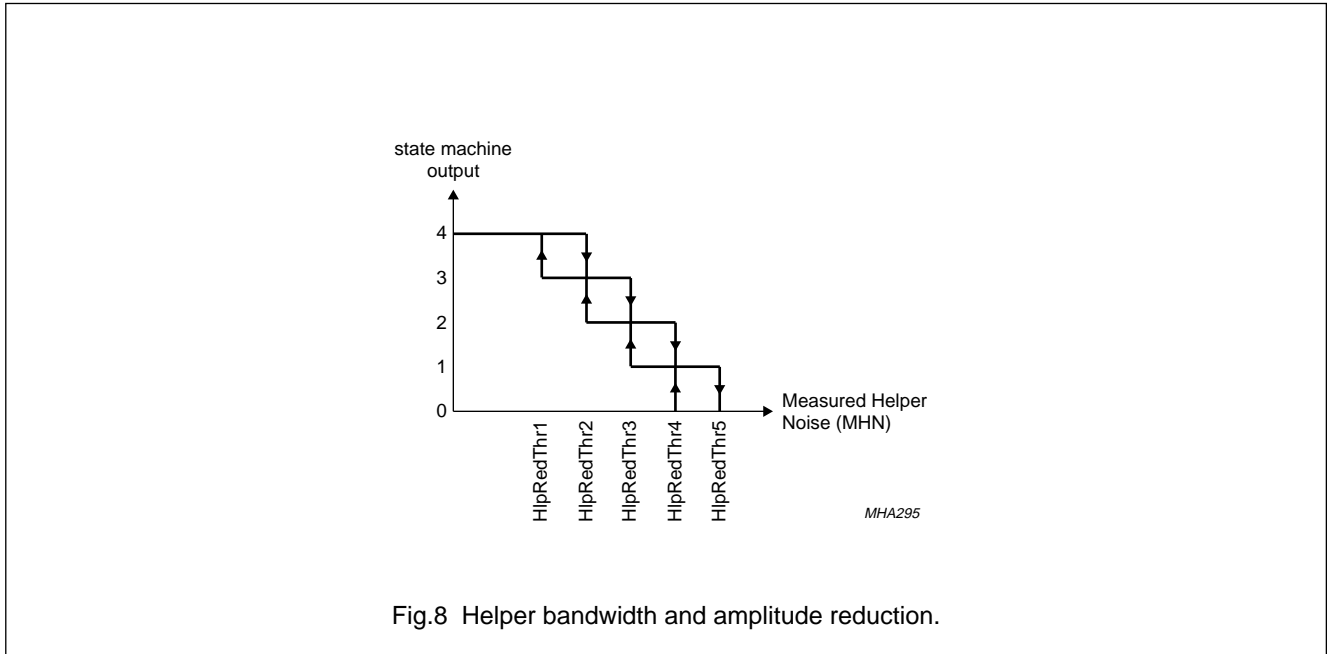

Fig.8 Helper bandwidth and amplitude reduction.

**Table 2** Measured Helper Noise in Zero (MHNZ)

MHNZ	STATE MACHINE (OLD)	STATE MACHINE (NEW)
$MHNZ < HlpRedThr1$	X	4
$HlpRedThr1 \leq MHNZ < HlpRedThr2$	4	4
	<4	3
$HlpRedThr2 \leq MHNZ < HlpRedThr3$	$\geq 3$	3
	<3	2
$HlpRedThr3 \leq MHNZ < HlpRedThr4$	$\geq 2$	2
	<2	1
$HlpRedThr4 \leq MHNZ < HlpRedThr5$	$\geq 1$	1
	0	0
$HlpRedThr5 \leq MHNZ$	X	0

**Table 3** State machine output

STATE MACHINE OUTPUT	REDUCE HELPER BANDWIDTH (RHB)	REDUCE HELPER AMPLITUDE (RHA)
4	0 (2.2 MHz LPF)	2; note 1
3	1 (1.0 MHz LPF)	2
2	1 (1.0 MHz LPF)	1; note 2
1	2 (0.5 MHz LPF)	1
0	2 (0.5 MHz LPF)	0; note 3

**Notes**

1. No helper amplitude reduction.
2. Helper amplitude reduction via LUT of about 50%.
3. Helper signal zero.

# Motion Adaptive Colour Plus And Control IC (MACPACIC) for PALplus

## SAA4996H

### 7.12 Chrominance

#### 7.12.1 INPUT RANGE

The input is a 4:1:1 sequential 4-bit wide UV signal with a 16 MHz clock frequency. Originally the U and V signals were 8 bits wide with a sampling frequency of 4 MHz each.

The range is  $0 \pm 90$  in two's complement format for U and V.

#### 7.12.2 CHROMINANCE PROCESSING

The Motion Adaptive Colour Plus technique is also applied in the chrominance processing to remove the luminance part from the incoming demodulated UV signal.

In the modulated domain the chrominance signal can be generated by subtracting the odd and even field data due to the  $180^\circ$  phase difference of the colour subcarrier. The colour decoder eliminates the phase difference of the chrominance signals, but now the luminance signals will obtain the phase difference of  $180^\circ$ .

By adding the odd and even field data, the cross-colour free chrominance signal (UVifa) is generated.

This processing will work successfully in the film mode, because scanned film material is motionless within the two fields of one frame. In the camera mode, where each field represents an individual picture, a motion detector fades down the chrominance high-pass component if motion is detected.

When chrominance motion occurs, the encoder fades down the high-pass luminance signal. In that event, the motion detector in the decoder will switch the chrominance part from intra frame average processing to the incoming data.

Odd and even field data are multiplexed and connected to the output of MACPACIC.

The chrominance processing has two input branches (see Fig.9). One input branch is the direct chrominance input path from the ADC. The other input branch is the output of the field memory FM1. The odd field of a frame is stored in the field memory FM1. In the even field of a frame the delayed odd field and the incoming even field are processed with the motion adaptive colour plus algorithm to the cross-colour free chrominance output data.

By adding the incoming chrominance signals of the odd and even fields, the intra frame average chrominance signal (UVifa) is generated.

For the chrominance motion detector this signal is stored after formatting in the memory FM4 (UV\_TO\_FM4).

#### 7.12.3 OUTPUT SIGNALS

The output data rate is 32 MHz for MACPACIC in combination with VERIC and 16 MHz for stand-alone MACPACIC or in the MultiPIP mode.

In the MultiPIP mode the chrominance data from the ADC (UV\_ADC) is switched directly to the output UV\_MA.

In the bypass mode the chrominance data processing is switched off and the multiplexed odd and even field data are connected to the MACPACIC output.

#### 7.12.4 OUTPUT RANGE

The range is  $0 \pm 90$  in two's complement format for U and V.

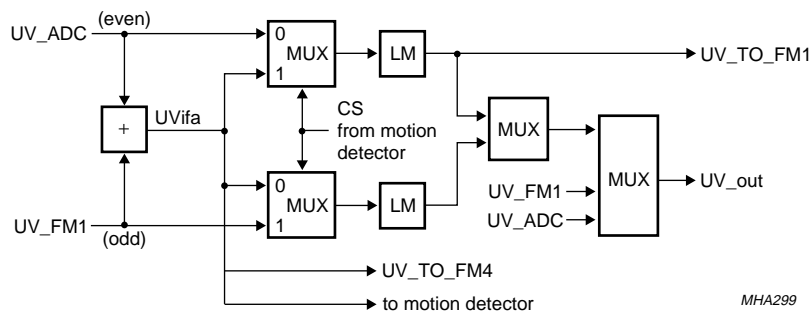

Fig.9 Chrominance processing.

## Motion Adaptive Colour Plus And Control IC (MACPACIC) for PALplus

SAA4996H

### 7.13 Chrominance motion detection

The PALplus system has two modes of operation. These are called film mode, which is only used with film sources, and camera mode which is applied for normal 50 Hz interlaced video sources. The motion detector is only necessary in the camera mode because, in the film mode, the two fields of a frame are sampled from the same picture of the film.

The chrominance motion detector has two input branches (see Fig.10). One input branch is the intra frame average of the actual frame, the other input branch is the intra frame average signal of the previous frame. This signal is delivered by the field memory FM4.

Subtraction of the two intra frame average signals generates the chrominance inter frame difference.

PAL averaging eliminates phase errors. This PAL averaging can be switched off when the PAL delay line in the colour decoder is active.

A look-up table (LUT) generates the motion signal from the chrominance signal. A comparator generates a chrominance control switch signal (CS). A horizontal interpolation filter interpolates a 16 MHz motion signal. The motion high-pass luminance control signal M\_YL is provided by another LUT.

### 7.14 Intelligent residual cross-luminance reduction (IRXR)

The IRXR block diagram is illustrated in Fig.10.

The MACP algorithm requires good stability of the sampling clock between both fields, because samples from both fields will be combined, in order to suppress cross-colour and cross-luminance. Investigations with currently used sync/clock circuitry have shown that the stability of these clocks is not as good as it should be for perfect performance of the MACP algorithm.

When a MACP signal is received the colour subcarrier trap in the TDA9144 is bypassed and the input signal of the SAA4996H still contains the modulated colour component. The MACP technique always processes corresponding lines of two successive fields (having an offset of 312 lines). These lines will have the same high-frequency luminance information (YH) and inverted colour information due to the phase/line relationship in PAL. With an ideal sampling grid, the two inverted colour signals will be cancelled completely by addition so that no cross-luminance (XL) remains in the resulting picture.

When the sampling grid is not optimum (e.g. shifted a little in one field with respect to the other field), the cancellation of both modulated colour signals will not be complete and some residual XL will remain. The amount of residual XL is proportional to the amplitude of the modulated colour signal and to the following formula;

$$\sin(\pi \times f_{sc} \times \text{timing\_error})$$

The timing error is determined by the type of circuitry used for the sync/clock generation and by the amount of noise/disturbance in the input signal (more noise/disturbance generally leads to larger timing errors).

The intelligent residual cross-luminance reduction (IRXR) tries to cancel this residual cross-luminance (XL), by reducing the amount of YH depending of the amplitude of the modulated colour signal.

The saturation indication signal (SD) is generated by the intra frame average signal of the actual frame with the help of a look-up table (LUT). A horizontal interpolation filter interpolates a 16 MHz saturation detection signal SD.

Another LUT transforms the SD signal into the signal SD\_YL, which determines the amount of YH to be reduced. Different characteristics curves of the LUT can be selected either via SNERT (SEL\_SD\_YL) or automatically depending on the measured noise value (SelSdYI), see Fig.11 and Table 4.

The IRXR function can be disabled or enabled via SNERT by the EN\_IRXR bit.

The output signal YL is generated from the three YH reduction signals SD\_YL, M\_YL and NM\_YL.

This combination is performed with a minimum detection circuit. The amount of YH that is allowed is the lowest of the three input signals. Whenever one input signal indicates a reason to reduce the YH, this should be performed independently of the other input signals.

In the event of film mode the signals NM\_YL (Fig.12 and Table 5) and M\_YL are over-written with the value 4. Motion detector processing is not active for these signals in the film mode. Such film overriding is not allowed for the SD\_YL signal, because the residual XL can occur in the film mode as well as in the camera mode.



Motion Adaptive Colour Plus And Control  
IC (MACPACIC) for PALplus

SAA4996H

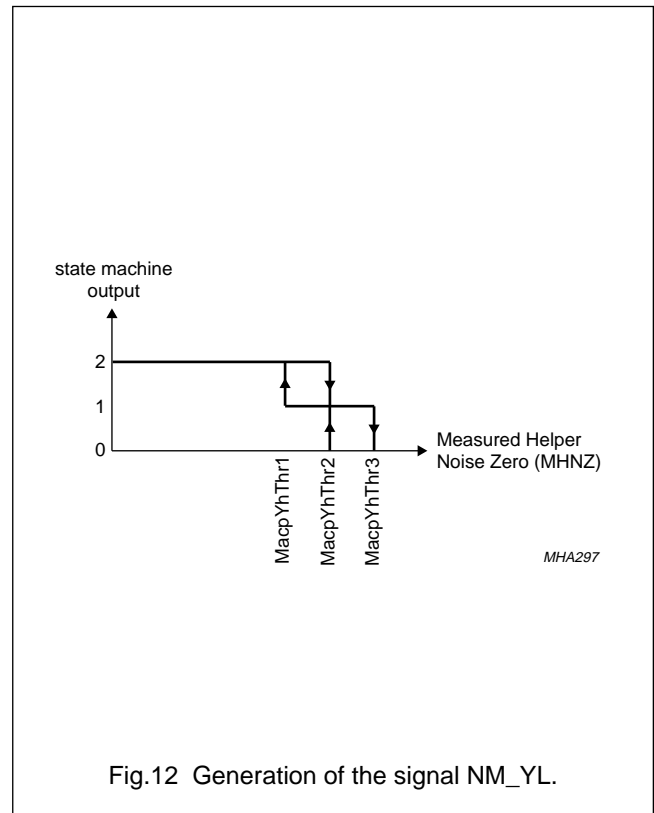
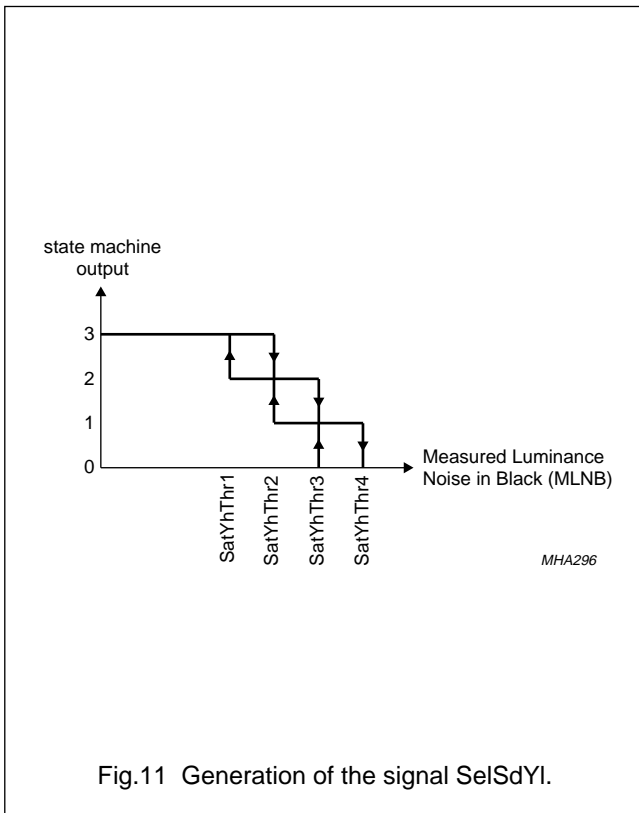

**Table 4** Measured luminance noise in black (MLNB)

MLNB	STATE MACHINE (OLD)	STATE MACHINE (NEW)
$MLNB < SatYhThr1$	X	3
$SatYhThr1 \leq MLNB < SatYhThr2$	3	3
	<3	2
$SatYhThr2 \leq MLNB < SatYhThr3$	$\geq 2$	2
	<2	1
$SatYhThr3 \leq MLNB < SatYhThr4$	$\geq 1$	1
	0	0
$SatYhThr3 \leq MLNB$	X	0

**Table 5** Generation of the signal NM\_YL

MHNZ	STATE MACHINE (OLD)	STATE MACHINE (NEW)	NM_YL
$MHNZ < MacpYhThr1$	X	2	4
$MacpYhThr1 \leq MHNZ < MacpYhThr2$	2	2	4
	<2	1	2
$MacpYhThr2 \leq MHNZ < MacpYhThr3$	$\geq 1$	1	2
	<1	0	0
$MacpYhThr3 < MHNZ$	X	0	0

Motion Adaptive Colour Plus And Control  
IC (MACPACIC) for PALplus

SAA4996H

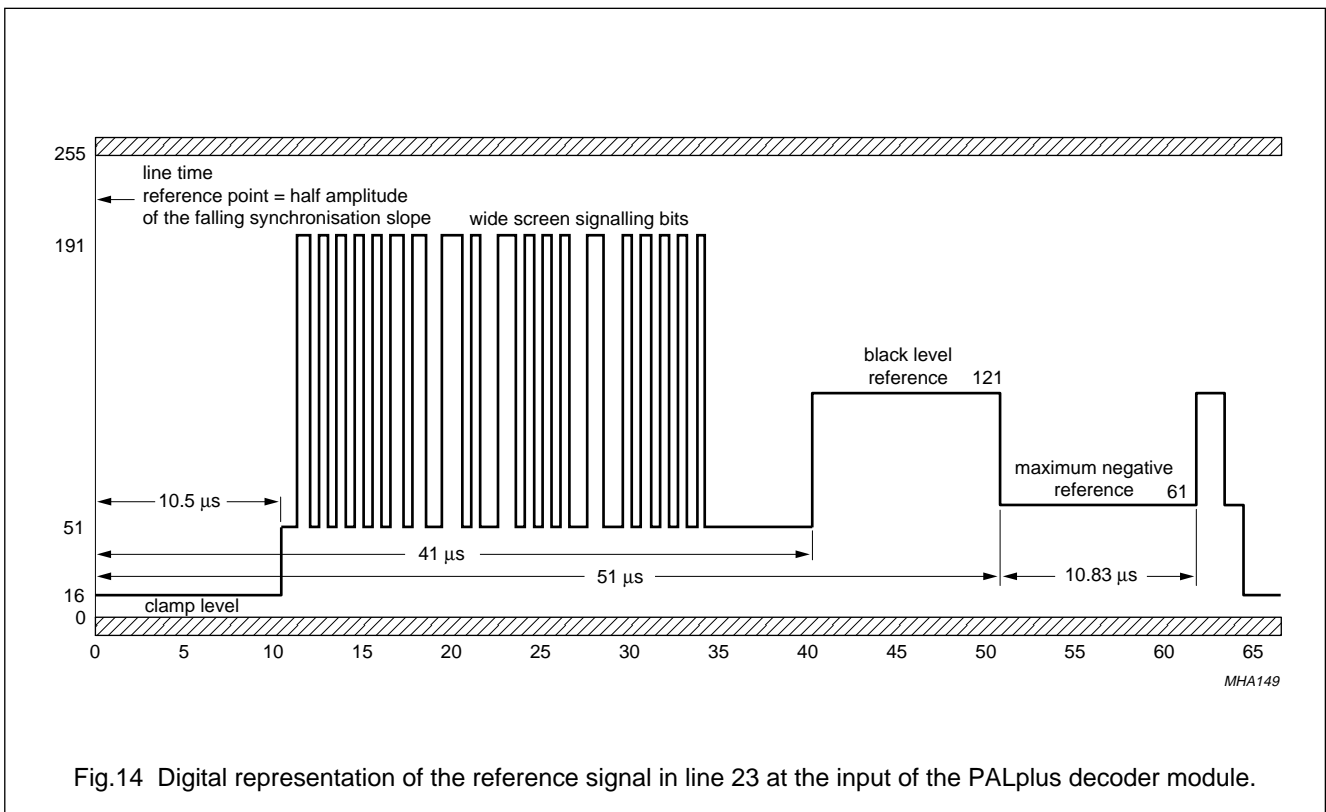
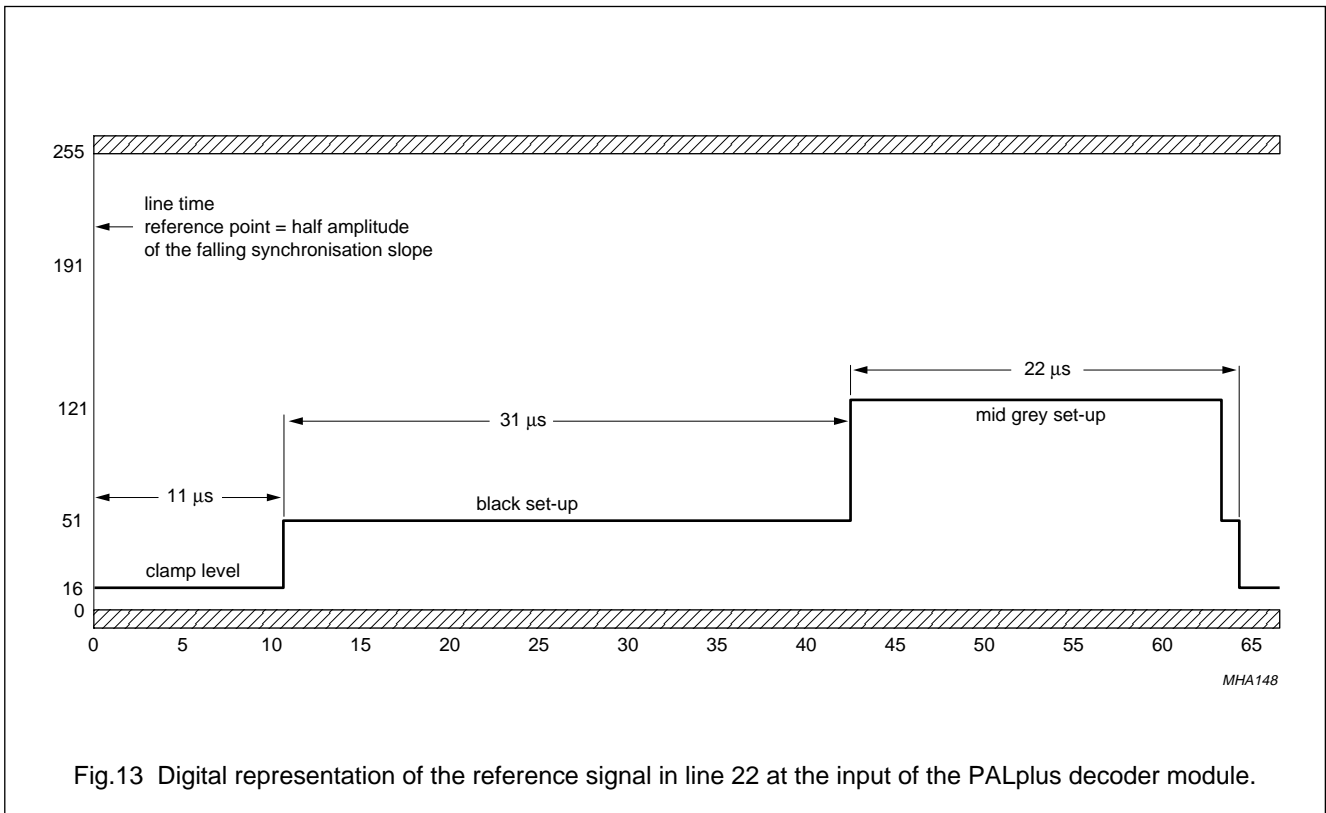



Motion Adaptive Colour Plus And Control  
IC (MACPACIC) for PALplus

SAA4996H

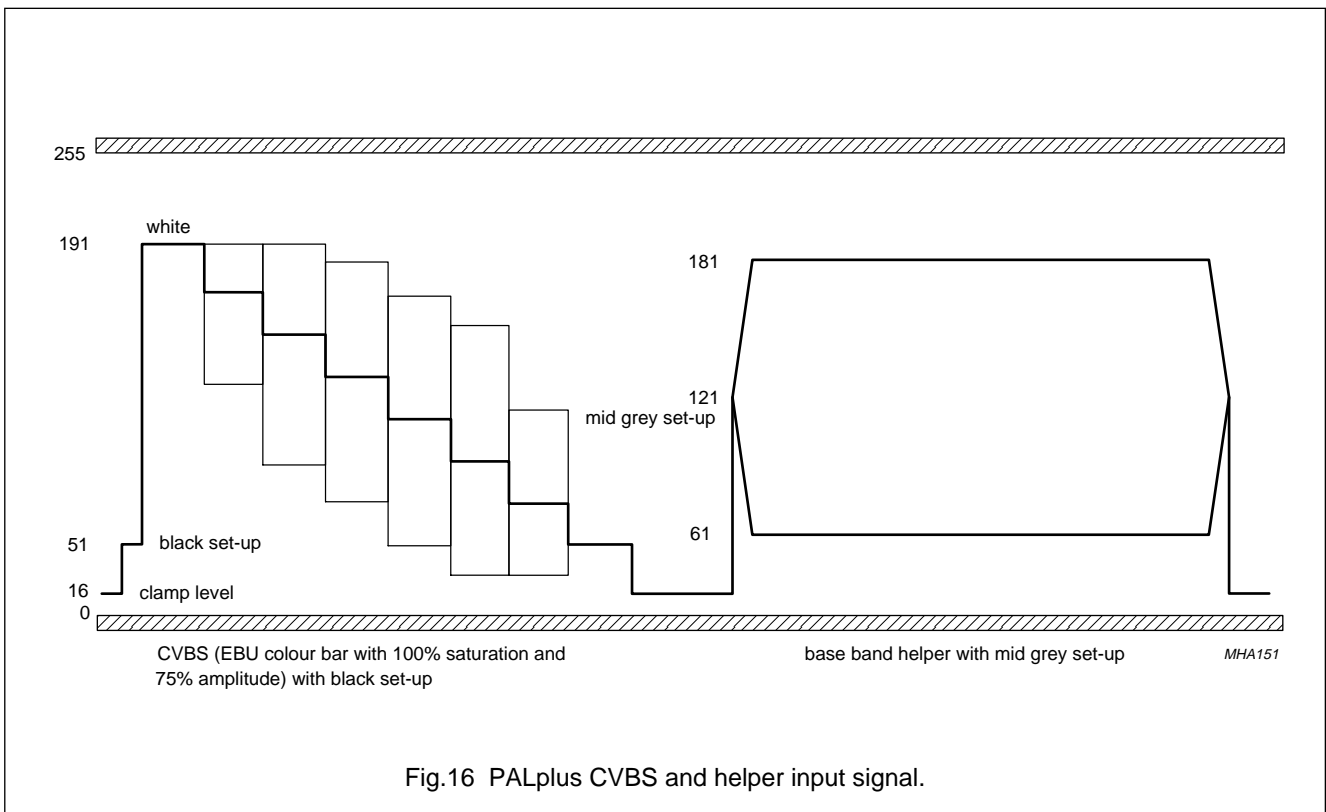
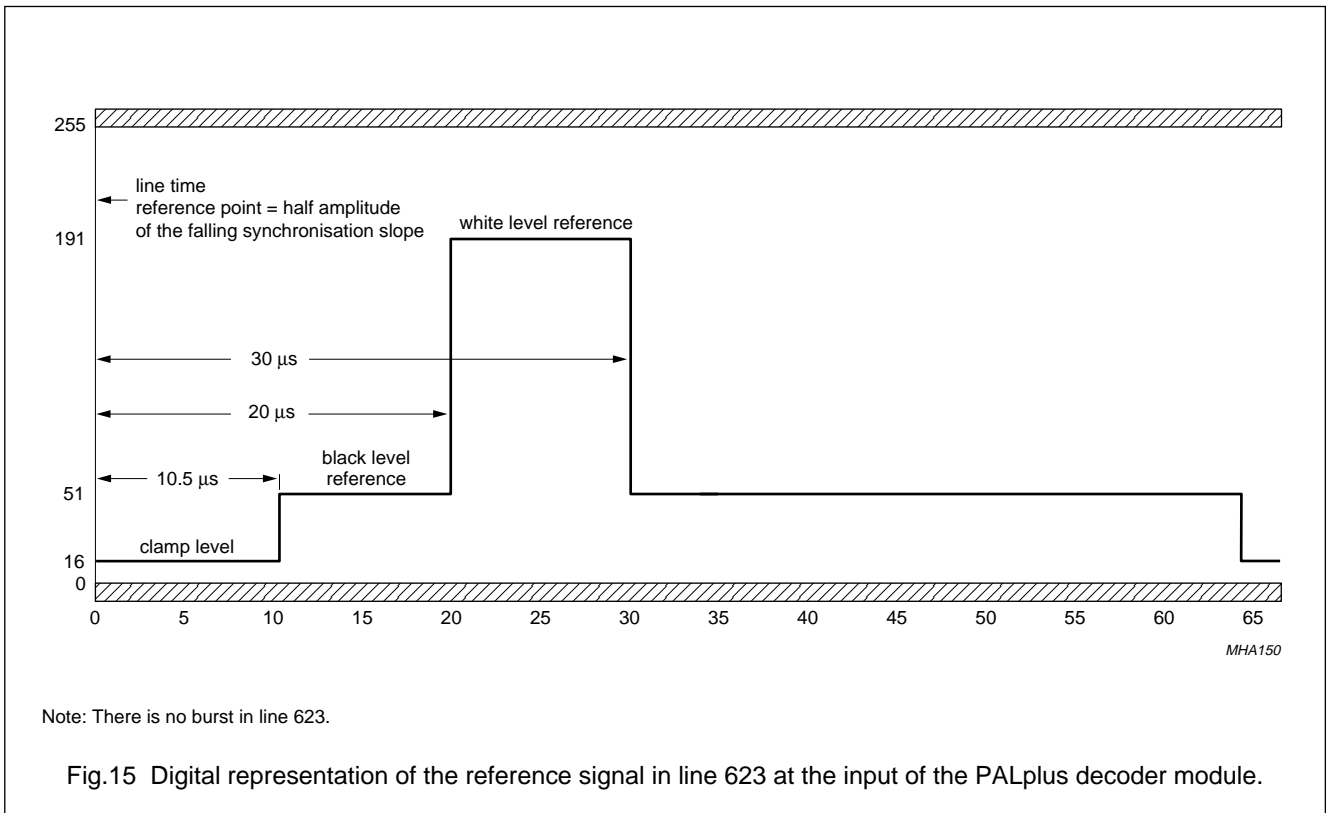

Motion Adaptive Colour Plus And Control  
IC (MACPACIC) for PALplus

SAA4996H

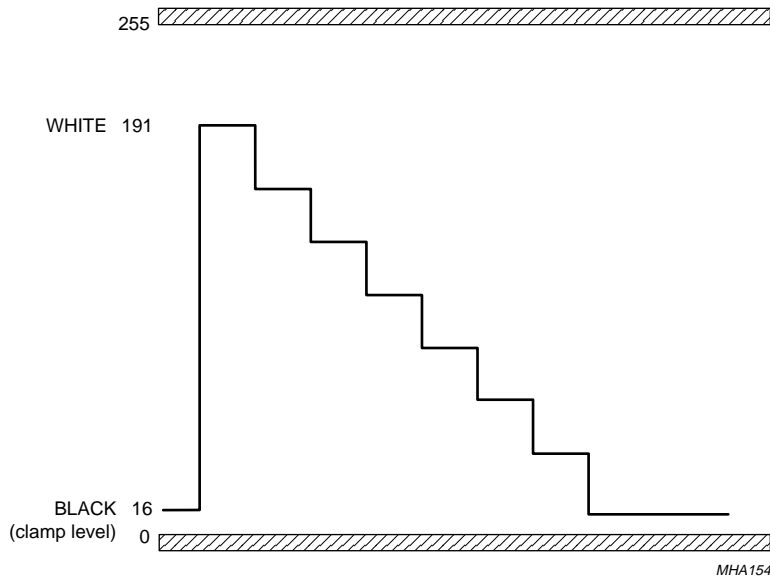

Fig.17 Non PALplus Y input signal.

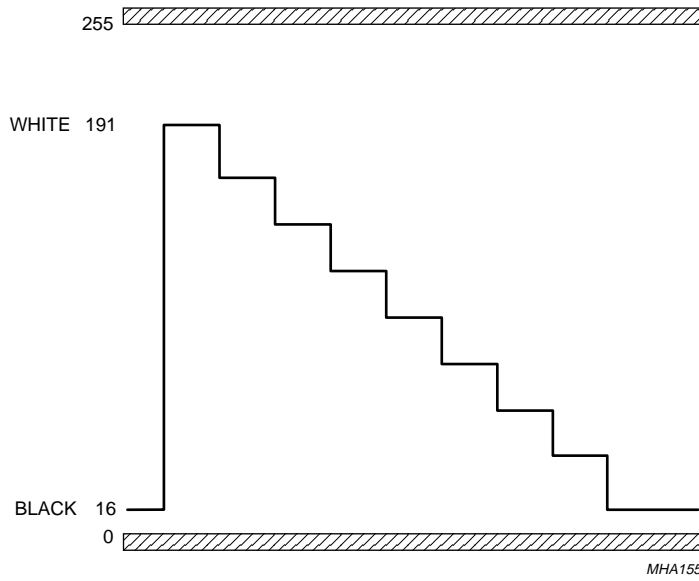

Fig.18 Y output signal.

Motion Adaptive Colour Plus And Control  
IC (MACPACIC) for PALplus

SAA4996H

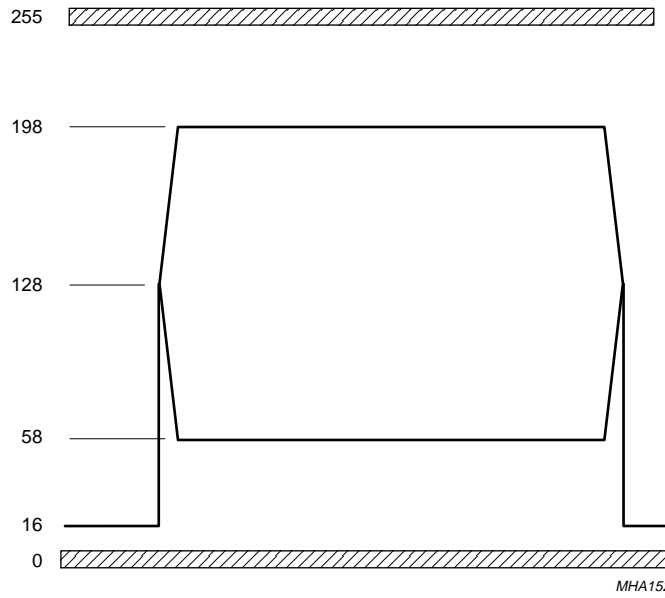

Fig.19 Helper output signal.

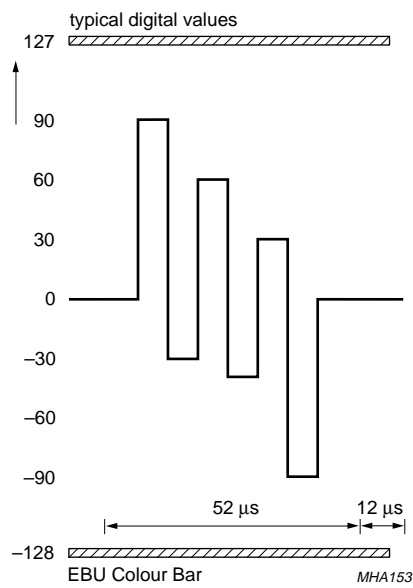

Fig.20  $-(B - Y)$  input and output signal.

Motion Adaptive Colour Plus And Control IC (MACPACIC) for PALplus

SAA4996H

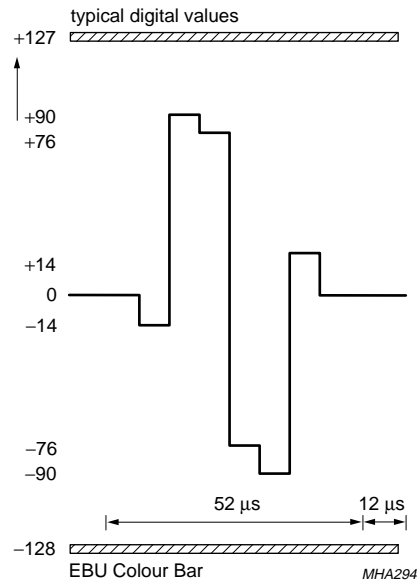

Fig.21  $-(R - Y)$  input and output signal.

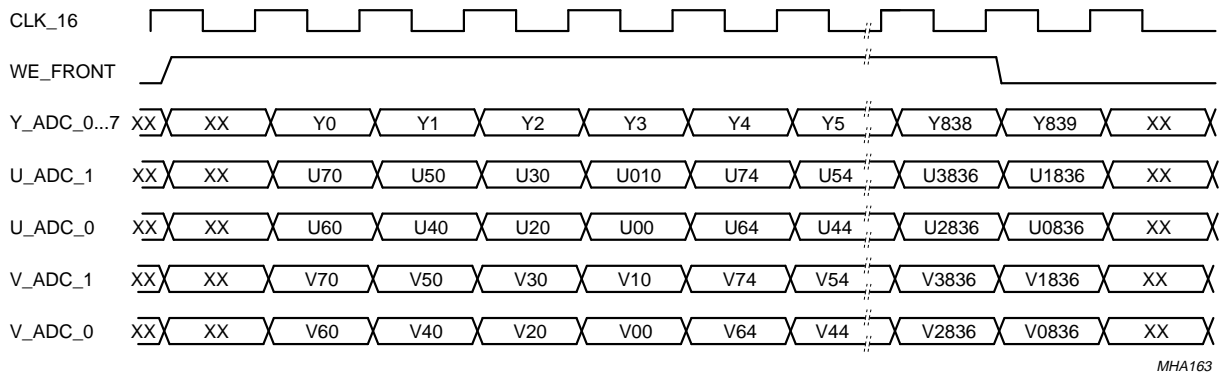

Fig.22 Horizontal data input timing.

Motion Adaptive Colour Plus And Control  
IC (MACPACIC) for PALplus

SAA4996H

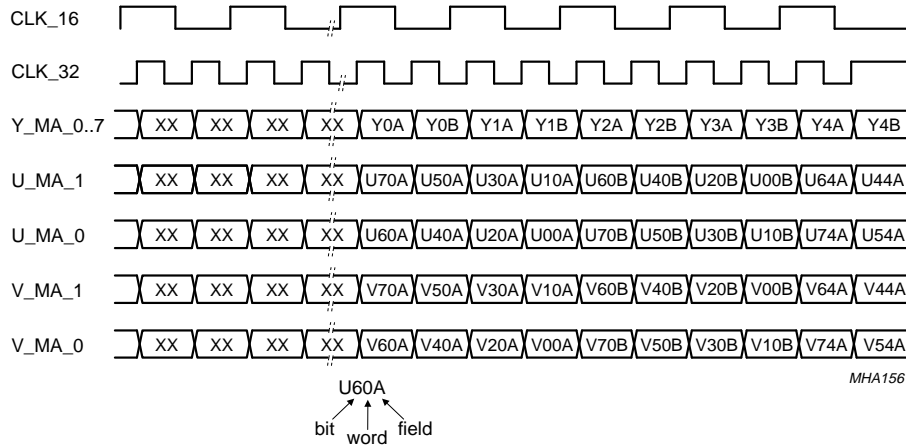

Fig.23 Horizontal output signals, full PALplus module.

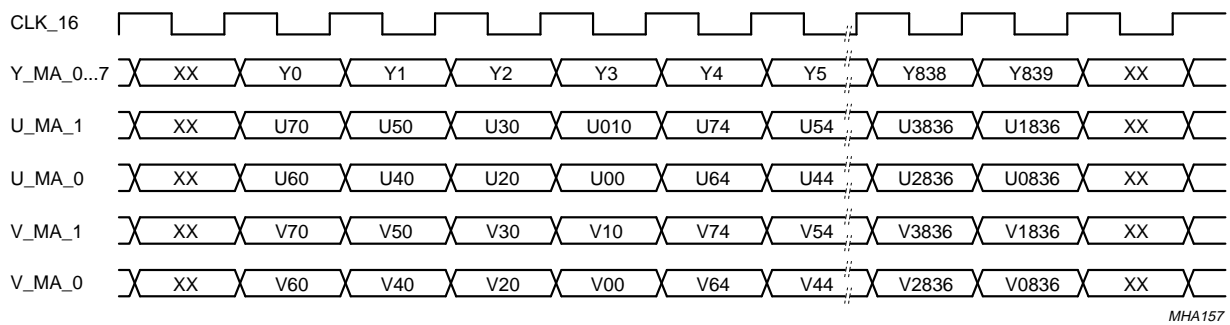

Fig.24 Horizontal output signals, stand-alone MACPACIC.

Motion Adaptive Colour Plus And Control  
IC (MACPACIC) for PALplus

SAA4996H

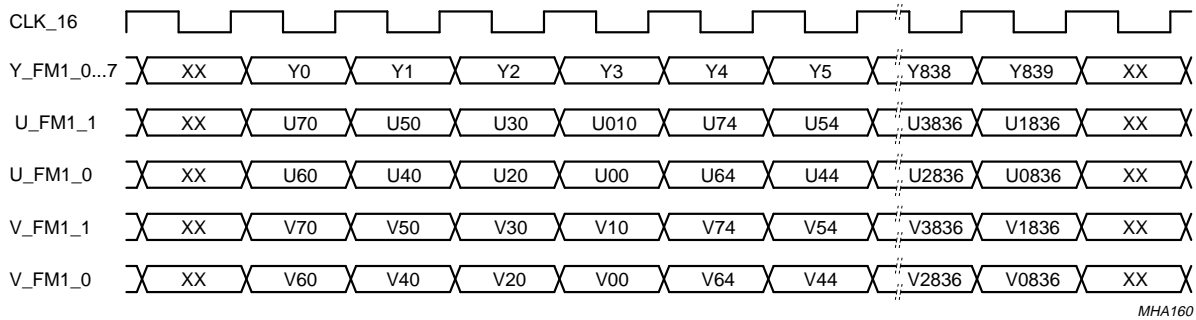

Fig.25 Horizontal timing, data from FM1.

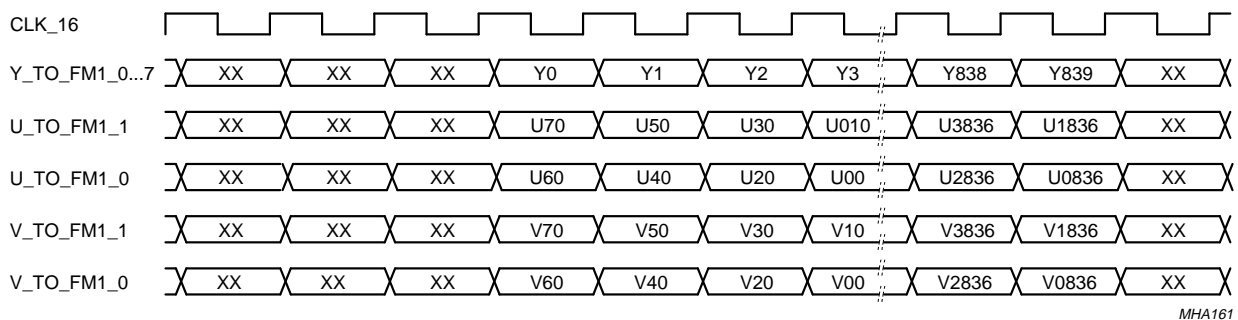

Fig.26 Horizontal timing, data to FM1 for stand-alone MACPACIC.

Motion Adaptive Colour Plus And Control  
IC (MACPACIC) for PALplus

SAA4996H

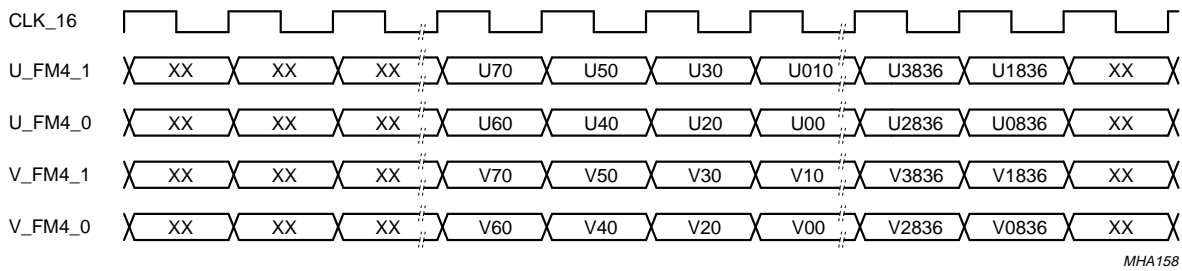

Fig.27 Horizontal timing, input signals from FM4.

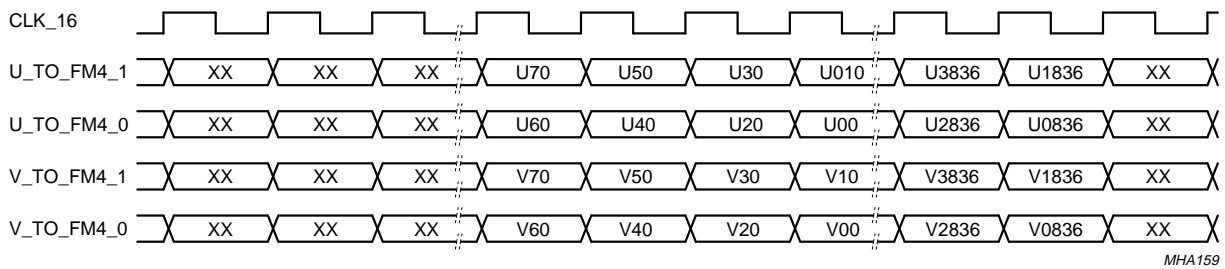

Fig.28 Horizontal timing, output signals to FM4.

Motion Adaptive Colour Plus And Control  
IC (MACPACIC) for PALplus

SAA4996H

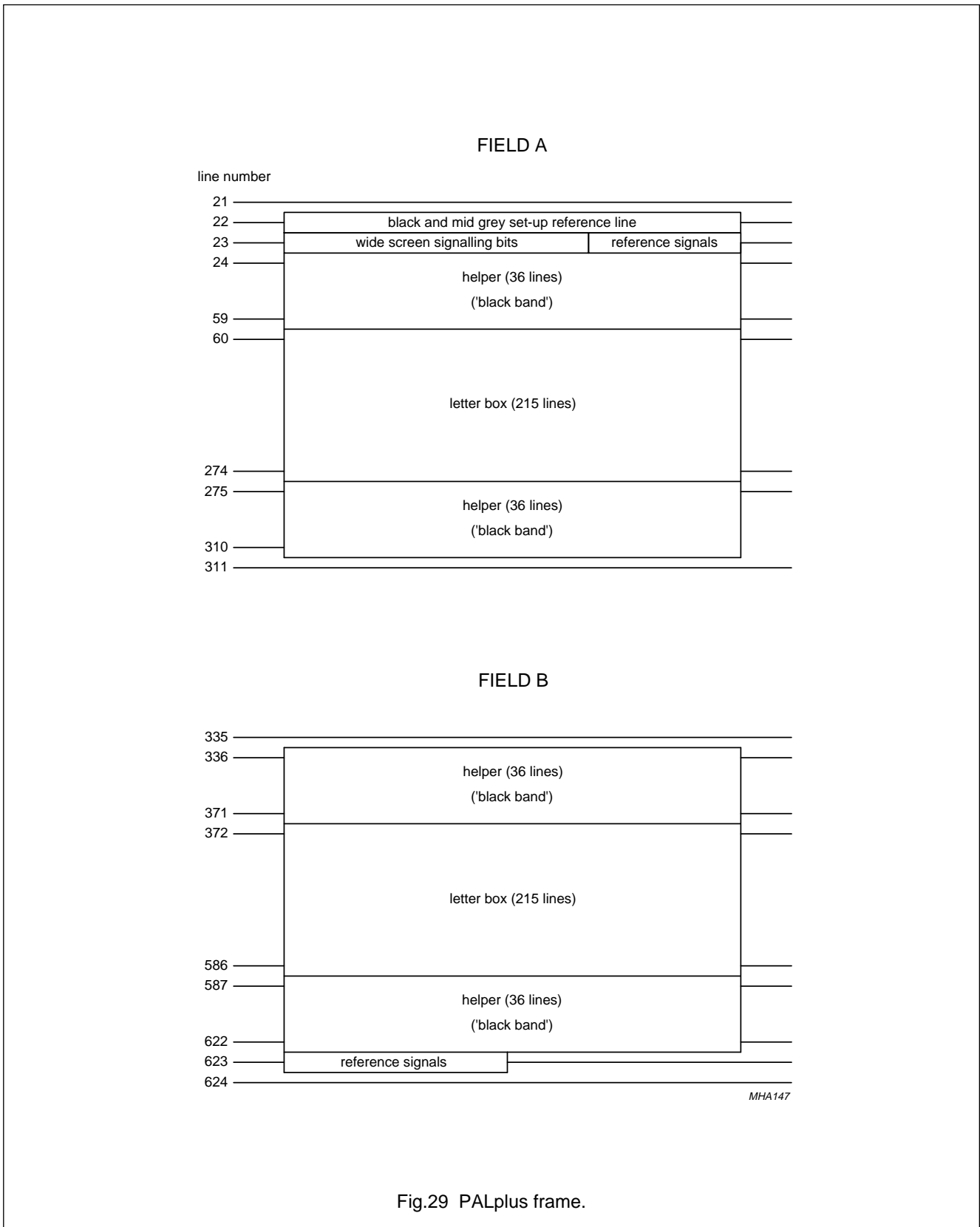

Fig.29 PALplus frame.



## Motion Adaptive Colour Plus And Control IC (MACPACIC) for PALplus

SAA4996H

### 7.15 Control

The control part (see Fig.2) generates all necessary internal control signals for the MACPACIC, the external control signals for the field memories FM1 to FM4 and the control signals for the VERIC. All of these signals are derived from the mode bits transmitted via the SNERT interface or from the reference input pins.

#### 7.15.1 INPUT REFERENCE SIGNALS

The horizontal reference signal is the rising edge of the CLAMP input pulse generated by the 100 Hz memory controller (see Fig.30). The rising edge of WE\_FRONT defines the first active horizontal sample of the incoming data Y\_FRONT. The vertical reference signal is the rising edge of VA\_FRONT (see Fig.32), derived from the synchronisation IC (e.g. TDA9144).

For PALplus input signals line 24 is the first processed line related to VA\_FRONT. When MACP or standard input signals are used, line 21 is the first processed line related to VA\_FRONT.

#### 7.15.2 FUNCTIONAL DESCRIPTION

The acquisition line counter (ACQ) is preset with the delayed rising edge of VA\_FRONT (see Fig.2). With the 'VA\_FRONT Delay' circuit it is possible to shift the rising edge of VA\_FRONT in multiples of CLK\_16 clock periods. This feature is necessary for unambiguous odd/even field detection. The delay can be set via the SNERT interface.

The ACQ line counter is preset with logic 1 at the beginning of the odd and even fields. The counter is enabled with the rising edge of the clamp signal.

The display line counter (DSP) is used in the event of a stand-alone MACPACIC (IVericN = 1) and is also preset with the delayed rising edge of VA\_FRONT. If VERIC is available the field length measurement is active. The display line counter is preset at the beginning of a displayed odd and even field with the rising edge of VA\_AI set to logic 1.

The pixel counter 1 is preset with the rising edge of the CLAMP pulse. The counter is clocked with the 16 MHz clock signal CLK\_16I.

The rising edge of WE\_FRONT marks the horizontal location of the first active input data of MACPACIC.

The signal WE\_MA defines the horizontal and vertical active area in which the first field memory (FM5) of the succeeding 100 Hz feature box stores incoming data.

The signal WE\_MA is generated by comparing (via the SNERT interface) the transmitted start and stop values with the values of the display line counter and the pixel counter 1.

The pixel counter 2 is preset with the rising edge of WE\_FRONT in such a way that the counter has the value '1' when the first active input data pixel is valid at the Y, UV\_ADC input of MACPACIC. This counter is a 10-bit modulo 1024 counter clocked with CLK\_16I.

##### 7.15.2.1 Memory control

The output of pixel counter 2 is used to generate the horizontal read and write enable signals for FM1 and FM4 and the write enable signals for the field memories FM2 and FM3. The read cycle for FM2 and FM3 is controlled by the VERIC.

The horizontal read and write signals are different for the full PALplus module, for stand-alone MACPACIC and for the odd and even fields. Therefore, the signals IVericN and EVEN\_FIELD are also input to the pixel decoder.

The output of the acquisition line counter is used to generate the vertical part of the read and write enable signals for FM1 and FM4 and the vertical part of the write enable signals for the field memories FM2 and FM3. The vertical read cycle for FM2 and FM3 is controlled by the VERIC.

The horizontal and vertical component of the read and write enable signals are different for the full PALplus module and for the stand-alone MACPACIC. The line values for the memory controlling are shown in Tables 6, 7 and 8.

# Motion Adaptive Colour Plus And Control IC (MACPACIC) for PALplus

SAA4996H

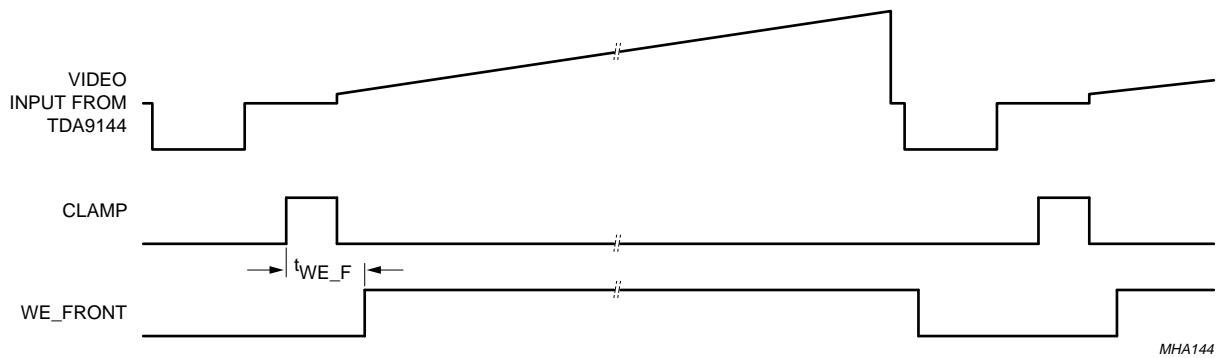

$t_{WE\_F}$ : CLAMP phase to WE is programmable via SNERT-bus.

Fig.30 Timing diagram of the horizontal reference input signals.

# Motion Adaptive Colour Plus And Control IC (MACPACIC) for PALplus

SAA4996H

**Table 6** Pixel values for horizontal memory control

EVEN_FIELD	IVericN	H_WE_FM1	H_RE_FM1	H_WE_FM2	H_WE_FM3	H_WE_FM4	H_RE_FM4
0	0	0 to 839	–	–	–	–	–
0	1	2 to 841	24 to 863	–	–	–	–
1	0	–	0 to 839	27 to 866	27 to 866	9 to 848	0 to 839
1	1	26 to 865	0 to 839	–	–	9 to 848	0 to 839

**Table 7** Line values for vertical memory control, PALplus signals

EVEN_FIELD	IVericN	V_WE_FM1	V_RE_FM1	V_WE_FM2	V_WE_FM3	V_RE_FM4	V_WE_FM4
0	0	21 to 311	–	–	–	–	–
0	1	21 to 311	21 to 311	–	–	–	–
1	0	–	20 to 310	24 to 59 167 to 274	60 to 166 275 to 310	21 to 311	21 to 311
1	1	22 to 312	20 to 310	–	–	21 to 311	21 to 311

**Table 8** Line values for vertical memory control, MACP and standard signals

EVEN_FIELD	IVericN	V_WE_FM1	V_RE_FM1	V_WE_FM2	V_WE_FM3	V_RE_FM4	V_WE_FM4
0	0	21 to 311	–	–	–	–	–
0	1	21 to 311	21 to 311	–	–	–	–
1	0	–	20 to 310	21 to 166	167 to 311	21 to 311	21 to 311
1	1	22 to 312	20 to 310	–	–	21 to 311	21 to 311

The horizontal and vertical memory control signals are combined in the H/V logic to generate the memory read and write signals.

In all modes, except the MultiPIP mode, the signal VA\_RES is used as a reset signal for the field memories FM1 to FM4 (RSTW\_FM23 and RST\_FM14). If the MultiPIP mode is selected, the signal VA\_AI is an input signal generated by an external memory controller. In this event the signal VA\_AI\_DIFF is used as RSTW\_FM23. The signal WE\_FM2 is set to logic 1 and all other read and write enable signals are set to logic 0. If the stand-alone MACPACIC and MultiPIP mode is selected, all memory control signals are set to logic 0.

The output pins 46 to 48 have different output signals depending on the environment in which MACPACIC is used. If it is part of a full PALplus module these pins deliver bits of chrominance data, in the stand-alone MACPACIC mode they output memory control signals (see Chapter "Pinning"). Selection of either mode is performed by the control signal IVericN.

### 7.15.2.2 The output signal HREF\_MA

The signal HREF\_MA is generated by delaying the CLAMP input signal two clocks CLK\_16. The HREF\_MA signal is used in the VERIC as a clock pulse for the internal line counter. The timing is illustrated in Fig.34.

### 7.15.2.3 VERIC control output signals

In the VERIC control decoder of MACPACIC the output signals FILM and INTPOL are generated as shown in Table 9.

# Motion Adaptive Colour Plus And Control IC (MACPACIC) for PALplus

SAA4996H

**Table 9** Generation of the signals FILM and INTPOL

22Valid	FilmOn	Mpip	HlpM0	HlpM1	FILM	INTPOL
1	0	0	0	0	0	0
1	0	0	0	1	0	1
1	0	0	1	0	0	1
1	0	0	1	1	0	1
1	1	0	0	0	0	0
1	1	0	0	1	1	1
1	1	0	1	0	1	1
1	1	0	1	1	1	1
0	0	0	0	0	0	0
0	0	0	0	1	0	1
0	0	0	1	0	0	1
0	0	0	1	1	0	1
0	1	0	0	0	0	0
0	1	0	0	1	0	1
0	1	0	1	0	0	1
0	1	0	1	1	0	1
X	X	1	X	X	1	0

### 7.15.2.4 Field length measurement

On the full PALplus module the field length is measured in the MACPACIC.

The ACQ line counter counts the lines between two succeeding vertical pulses. The one-line-long vertical output signal VA\_AI has a delay of 1.5 fields with respect to the delayed VA\_FRONT input signal and has the same phase relationship to the CLAMP input signal for various video input signals (VCR, NTSC).

For the stand-alone MACPACIC the 2.5 H signal VA\_FR\_DEL is selected by the control signal IVericN as the vertical reference output signal VA\_AI.

### 7.15.2.5 Field detection

To detect the current odd or even field, the location of the delayed VA\_FRONT (VA\_RES) input signal inside a line has to be located.

For a PALplus video input signal the output signal EVEN\_FIELD is generated by enabling a register with the VA\_RES signal, which has the MSB of the pixel counter 2 at the D input.

In the bypass or MultiPIP mode the toggle function of the register is active.

The odd/even field detection can be inverted by the SNERT control bit InvO/E.

It is also possible to define the EVEN\_FIELD signal by software via a SNERT transmission.

### 7.15.2.6 Pins VA\_FRONT and VA\_AI

The signals VA\_FRONT and VA\_AI have bidirectional functions. In all modes, except the MultiPIP mode, the pin VA\_FRONT is an input pin and the pin VA\_AI is an output pin. If the MultiPIP mode is selected the pin VA\_AI is an input pin and the signal is connected to the VA\_FRONT pin which now becomes an output pin (see Fig.2 and Fig.35).

### 7.15.3 SNERT INTERFACE (SEE APPLICATION NOTE AN95XXX)

In the SNERT interface the external signals SNERT\_CL and SNERT\_DA are processed to address and data. A synchronisation to the bus performed with the reset signal SNERT\_RST. The transmitted data is valid with the next rising edge of SNERT\_RST.

The block diagram and the data, clock and reset timing of the SNERT interface are shown in Fig.3 and Fig.36.

## Motion Adaptive Colour Plus And Control IC (MACPACIC) for PALplus

SAA4996H

### 7.15.3.1 Serial interface protocol

**Power-on state:** After power-on the serial interface is in an unknown state. The information in the actual data registers is random. When signals are applied to SNERT\_CL and SNERT\_DA in this state, the behaviour is unpredictable.

**Initialization state:** After power-on, or in any other state, the initialization state is entered after the rising edge of the signal SNERT\_RST. The SNERT clock counter C1 is reset with the rising edge of SNERT\_RST. The data registers remain loaded with the last transmitted values.

**Address reception state:** After reset the address reception state is entered. On each negative edge of SNERT\_CL the next data bit from SNERT\_DA is shifted into the input shift register. The counter is incremented with each rising edge of SNERT\_CL. After the 8th negative edge of SNERT\_CL the Address Latch Enable (ALE) pulse is generated. With this enable pulse the contents of the shift register is loaded into the address register. If an address in the range 50H to 64H, 67H or 68H is decoded, one of the 8-bit wide input data registers is selected.

**Data reception state:** If a valid address is received, the next eight bits on SNERT\_DA are considered as data bits. When the 8 data bits have been shifted into the shift register the counter enables the loading of the data word in one of the 23 data registers in combination with the decoded address.

There are three data register banks;

- The actual data register bank
- The acquisition data register bank
- The synchronizing register bank.

After a SNERT transmission is completed another SNRST pulse must follow in order to enable the acquisition registers and make the data valid. The synchronizing registers are enabled with the signals 'line2\_odd\_every\_field' respectively 'line2\_every\_field', which are related to the vertical reference input signal VA\_FRONT.

**Data send state:** If the transmitted address is 65H or 66H, the 'send\_rcv' signal defines the SNERT\_DA pin as an output and, with the positive edge of the next 8 SNERT\_CL pulses generated by the microcontroller, the data output register is read out.

### 7.15.3.2 Special SNERT transmission requirements

#### **EVEN\_FIELD definition:**

After switching on the MACPACIC, the EVEN\_FIELD output signal toggles.

When the EVEN\_FIELD signal accidentally toggles in the right way (EVEN\_FIELD = 0, odd field) and when a PALplus input signal is present, the line 22 is detected. Then the internal field detection is active and the normal data processing starts up.

When the EVEN\_FIELD signal toggles in the wrong way (EVEN\_FIELD = 0, even field), line 22 will never be detected and the field detection remains in this wrong behaviour.

**Solution:** After switching on the MACPACIC or after switching into PALplus or MACP mode, the EVEN\_FIELD output signal has to be defined by the control bits 'EnPreEvFld' and 'PreEvFld' of the control 6 SNERT register.

#### **Luminance offset hysteresis control:**

For luminance offset control a hysteresis function is applied to the measured luminance offset. The hysteresis function is controlled by the three black offset hysteresis control bits BOH0, BOH1 and BOH2 transmitted via SNERT (control 5 data register).

To guarantee the correct hysteresis function, the following software actions are necessary:

First the hysteresis has to be set to zero via SNERT (BOH = 0). After a PALplus input signal is detected (line 22 is valid), the actual black offset is measured in the next frame. During this time (40 ms) the software remains in the stand-by position. One of the possible hysteresis values can then be transmitted via SNERT.

Motion Adaptive Colour Plus And Control IC (MACPACIC) for PALplus

SAA4996H

7.15.3.3 Address and data overview  
**Table 10** Address and data overview  
 Address 50H to 64H, 67H and 68H contains write data (data from microprocessor); address 65H and 66H contains read data (data to microcontroller).

ADDRESS (HEX)	FUNCTION	DATA BYTE									
		D7	D6	D5	D4	D3	D2	D1	D0		
50	Control1	Preset	MacpOn	HlpM1	HlpM0	FilmOn	MotVis1	MotVis0	InvO/E		
51	Control2	Mpip	VaDel2	VaDel1	VaDel0	FastTest	WeShift16_1	WeShift16_0	EnIRXR		
52	WeStrtH	StrtH7	StrtH6	StrtH5	StrtH4	StrtH3	StrtH2	StrtH1	StrtH0		
53	WeStpH	StpH7	StpH6	StpH5	StpH4	StpH3	StpH2	StpH1	StpH0		
54	WeStrtV0	StrtV07	StrtV06	StrtV05	StrtV04	StrtV03	StrtV02	StrtV01	StrtV00		
55	WeStrtV1	StrtV17	StrtV16	StrtV15	StrtV14	StrtV13	StrtV12	StrtV11	StrtV10		
56	WeStpV0	StpV07	StpV06	StpV05	StpV04	StpV03	StpV02	StpV01	StpV00		
57	WeStpV1	StpV17	StpV16	StpV15	StpV14	StpV13	StpV12	StpV11	StpV10		
58	HlpRedThr1	HlpThr17	HlpThr16	HlpThr15	HlpThr14	HlpThr13	HlpThr12	HlpThr11	HlpThr10		
59	HlpRedThr2	HlpThr27	HlpThr26	HlpThr25	HlpThr24	HlpThr23	HlpThr22	HlpThr21	HlpThr20		
5A	HlpRedThr3	HlpThr37	HlpThr36	HlpThr35	HlpThr34	HlpThr33	HlpThr32	HlpThr31	HlpThr30		
5B	HlpRedThr4	HlpThr47	HlpThr46	HlpThr45	HlpThr44	HlpThr43	HlpThr42	HlpThr41	HlpThr40		
5C	HlpRedThr5	HlpThr57	HlpThr56	HlpThr55	HlpThr54	HlpThr53	HlpThr52	HlpThr51	HlpThr50		
5D	MacpYhThr1	MaThr17	MaThr16	MaThr15	MaThr14	MaThr13	MaThr12	MaThr11	MaThr10		
5E	MacpYhThr2	MaThr27	MaThr26	MaThr25	MaThr24	MaThr23	MaThr22	MaThr21	MaThr20		
5F	MacpYhThr3	MaThr37	MaThr36	MaThr35	MaThr34	MaThr33	MaThr32	MaThr31	MaThr30		
60	IrxrThr1	IrxrThr17	IrxrThr16	IrxrThr15	IrxrThr14	IrxrThr13	IrxrThr12	IrxrThr11	IrxrThr10		
61	IrxrThr2	IrxrThr27	IrxrThr26	IrxrThr25	IrxrThr24	IrxrThr23	IrxrThr22	IrxrThr21	IrxrThr20		
62	IrxrThr3	IrxrThr37	IrxrThr36	IrxrThr35	IrxrThr34	IrxrThr33	IrxrThr32	IrxrThr31	IrxrThr30		
63	IrxrThr4	IrxrThr47	IrxrThr46	IrxrThr45	IrxrThr44	IrxrThr43	IrxrThr42	IrxrThr41	IrxrThr40		
64	FixHlpMain	FixHlp3	FixHlp2	FixHlp1	FixHlp0	FixMain3	FixMain2	FixMain1	FixMain0		
65	Control3	X <sup>(1)</sup>	X <sup>(1)</sup>	X <sup>(1)</sup>	22Valid	623Valid	23Valid	IvericN	IMacpacticN		
66	Control4	X <sup>(1)</sup>	SeISdY11	SeISdY10	NmY11	NmY10	Rha/Rhb2	Rha/Rhb1	Rha/Rhb0		
67	Control5	BOH2	BOH1	BOH0	VAA1	VAA0	SEL_SD_YL1	SEL_SD_YL0	NAIRXR		
68	Control6	Interlace	EnPreEvFld	PreEvFld	X <sup>(2)</sup>	X <sup>(2)</sup>	X <sup>(2)</sup>	X <sup>(2)</sup>	X <sup>(2)</sup>		

**Notes**

1. Bits not valid.
2. Don't care (bits can be logic 0 or logic 1).

# Motion Adaptive Colour Plus And Control IC (MACPACIC) for PALplus

SAA4996H

## 7.15.3.4 Command explanation

**Table 11** Control1

ADDRESS (HEX)	R/W	BIT	NAME	FUNCTION
50	W	7	Preset	0: normal processing
				1: abandon the recursive measurement loops and load the circuits with actual video data
		6	MacpOn	0: Motion Adaptive Colour Plus decoding not activated
				1: Motion Adaptive Colour Plus decoding activated
		5, 4	HlpM1 and HlpM0	00: bypass mode VERIC
				01: vertical up-conversion without use of helper
				10: vertical enhancement with adaptive helper processing
		3	FilmOn	0: camera mode activated
				1: film mode activated
		2, 1	MotVis1 and MotVis0	00: don't show motion decisions
				01: show Y motion decisions
				10: show C motion decisions
11: show M motion decisions				
0	InvO/E	0: don't invert EVEN_FIELD definition		
		1: invert EVEN_FIELD definition		

**Table 12** Control2

ADDRESS (HEX)	R/W	BIT	NAME	FUNCTION
51	W	7	Mpip	0: MultiPIP mode not active
				1: MultiPIP with the help of PIP module is activated; VA_AI is set to input and VA_FRONT to output; the signal at the WE_FRONT pin is used
		6 to 4	VaDel2, VaDel1 and VaDel0	internal delay of VA_FRONT in multiples of CLK_16 clock periods; range: [0, 64, 128 to 448] CLK_16 periods; this feature is required for unambiguous Odd/Even field detection
		3	FastTest	0: normal mode: activating new SNERT commands at frame boundaries related to VA_FRONT (address 50H to 57H and 68H)
				1: activating new SNERT commands immediately
2, 1	WeShift16_1 and WeShift16_0	shift of WE_MA of 0 to 3 16 MHz samples related to the positive edge of CLAMP		
0	EnIRXR	0: disable Intelligent Residual cross-luminance Reduction		
		1: enable Intelligent Residual cross-luminance Reduction		

Motion Adaptive Colour Plus And Control IC (MACPACIC) for PALplus

SAA4996H

Table 13 Programming of WE\_MA

ADDRESS (HEX)	R/W	BIT	NAME	FUNCTION
52	W	7 to 0	WeStrtH	distance between rising edge of CLAMP and rising edge of WE_MA in multiples of 4 CLK_16 periods
53	W	7 to 0	WeStpH	distance between rising edge of CLAMP and falling edge of WE_MA in multiples of 4 CLK_16 periods
54	W	7 to 0	WeStrtV0	number of lines between rising edge of VA_AI (VA_FRONT) and first active WE_MA line
55	W	7 to 0	WeStrtV1	
56	W	7 to 0	WeStpV0	number of lines between rising edge of VA_AI (VA_FRONT) and first non-active WE_MA line
57	W	7 to 0	WeStpV1	

WeStrtH, WeStpH, WeStrtV and WeStpV:

The horizontal reference is the rising edge of the CLAMP signal. The vertical reference is the rising edge of the VA\_FRONT signal. This signal is set via software. Signals WeStrtH and WeStpH define the horizontal active area. Signals (WeStrtV0 and WeStrtV1) and (WeStpV0 and WeStpV1) mark the vertical active area. The least significant bit of the start and stop address is also the most significant bit of the data.

Because the number of 16 MHz samples in a line is 1024, and one data byte can only define 256 positions, the horizontal start and stop positions are defined with a 4 MHz resolution. To reach the full 16 MHz resolution the

signals WeShift16\_0 and WeShift16\_1 shifts the active horizontal area over 0 to 3 clock periods of 16 MHz. In this case the positive as well as the negative edge will shift over the same amount of samples.

WeStrtV0 indicates the vertical start addresses 1 to 256 and WeStrtV1 indicates the addresses 257 to 512. The vertical start at line 1 is not allowed. WeStpV0 indicates the vertical stop addresses 1 to 256 and WeStpV1 indicates the addresses 257 to 512.

If WeStrtH = WeStpH and WeStrtV0 = WeStpV0 or WeStrtV1 = WeStpV1 the output control signal WE\_MA is switched to a LOW level and no data will be written into the succeeding module (still picture).

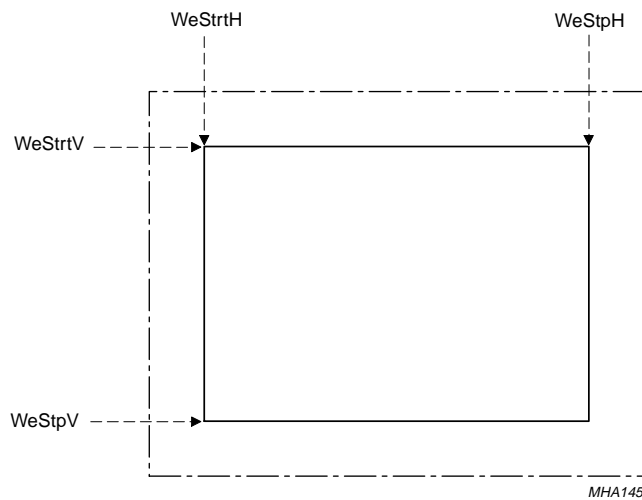

Fig.31 Boundaries of the WE\_MA signal.



# Motion Adaptive Colour Plus And Control IC (MACPACIC) for PALplus

SAA4996H

**Table 14** Helper Reduction Thresholds

ADDRESS (HEX)	R/W	BIT	NAME	FUNCTION
58	W	7 to 0	HlpRedThr1	5 thresholds defining the ranges in which the 5 modes for adaptive helper reduction will be applied (inclusive hysteresis); this adaptivity prevents from artefacts of helper noise break through
59	W	7 to 0	HlpRedThr2	
5A	W	7 to 0	HlpRedThr3	
5B	W	7 to 0	HlpRedThr4	
5C	W	7 to 0	HlpRedThr5	

**Table 15** Definition of Y\_HP Reduction Thresholds related to MACP

ADDRESS (HEX)	R/W	BIT	NAME	FUNCTION
5D	W	7 to 0	MacpYhThr1	3 thresholds defining the ranges in which the 3 modes for adaptive Yhp reduction will be applied (inclusive hysteresis)
5E	W	7 to 0	MacpYhThr2	
5F	W	7 to 0	MacpYhThr3	

**Table 16** Definition of Y\_HP Reduction Thresholds related to PLL disturbances

ADDRESS (HEX)	R/W	BIT	NAME	FUNCTION
60	W	7 to 0	IrxrThr1	4 thresholds defining the ranges in which the 4 modes for the intelligent residual cross-luminance reduction will be applied; this adaptivity prevents from artefacts caused by the PLL disturbance
61	W	7 to 0	IrxrThr2	
62	W	7 to 0	IrxrThr3	
63	W	7 to 0	IrxrThr4	

**Table 17** Definition of fixed helper gain and relative main amplitude (FixHlpMain)

ADDRESS (HEX)	R/W	BIT	NAME	FUNCTION
64	W	7 to 4	FixHlp3, FixHlp2, FixHlp1, FixHlp0	definition of helper gain
		3 to 0	FixMain3, FixMain2, FixMain1, FixMain0	definition of relative main amplitude (letter box)

Motion Adaptive Colour Plus And Control  
IC (MACPACIC) for PALplus

SAA4996H

Table 18 Control3

ADDRESS (HEX)	R/W	BIT	NAME	FUNCTION
65	R	7 to 5	X	no function
		4	22Valid	0: correct MACP and/or helper processing is not possible and is automatically switched off; helpers are blanked and MACPACIC is forced into camera mode; reference levels of line 22 are not valid
				1: correct MACP and/or helper processing could be possible; reference levels of line 22 are valid
		3	623Valid	0: correct helper processing is not possible and is automatically switched off; reference values of line 623 are not valid
				1: correct helper processing could be possible; reference values of line 623 are valid
		2	23Valid	0: correct helper processing is not possible and is automatically switched off; reference values of line 23 are not valid
				1: correct helper processing could be possible; reference values of line 23 are valid
		1	IVericN	0: VERIC available
1: VERIC not available				
0	IMacpacicN	0: MACPACIC available		
		1: MACPACIC not available		

Table 19 Control4

ADDRESS (HEX)	R/W	BIT	NAME	FUNCTION
66	R	7	X	no function
		6, 5	SeISdY11, SeISdY10	indication of the Y_HP reduction factor, which is further saturation dependent; these are deduced from the noise within full band (line 623)
		4, 3	NmY11, NmY10	indication of the Y_HP reduction factor deduced from the noise within the helper (line 23)
		2 to 0	Rha/Rhb2, Rha/Rhb1, Rha/Rhb0	indication of the amount of helper bandwidth reduction and helper amplitude reduction; these are deduced from the noise within the helper (line 23)

# Motion Adaptive Colour Plus And Control IC (MACPACIC) for PALplus

SAA4996H

Table 20 Control5

ADDRESS (HEX)	R/W	BIT	NAME	FUNCTION
67	W	7 to 5	BOH2, BOH1, BOH0	selection of black offset hysteresis: 000: 0 001: $\pm 1$ 010: $\pm 2$ 011: $\pm 3$ 100: $\pm 4$ 101: $\pm 5$ 110: $\pm 6$ 111: fixed black offset (51)
		4, 3	VAA1 and VAA0	selection of the coefficients of the luminance vertical anti-alias filter (DEC_Y_VAA): see Table 21
		2, 1	SEL_SD_YL1, SEL_SD_YL0	selection of IRXR characteristics (NAIRXR = 0): see Table 22
		0	NAIRXR	0: IRXR table selection dependent of SEL_SD_YL 1: noise adaptive IRXR table selection

Table 21 DEC\_Y\_VAA

VAA1	VAA0	SELECTION OF THE LUMINANCE VERTICAL ANTI-ALIAS FILTER (DEC_Y_VAA)			
		FIELD	COEFF1	COEFF2	COEFF3
0	0	odd	2	7	-1
0	0	even	-1	7	2
0	1	X	2	4	2
1	0	X	3	2	3
1	1	X	4	0	4

Table 22 IRXR

SEL_SD_YL	SELECTION OF IRXR CHARACTERISTICS (NAIRXR = 0)															
	0	1	2	3	4	5	6	7	8	9	A	B	C	D	E	F
0	4	4	3	2	1	0	0	0	0	0	0	0	0	0	0	0
1	4	4	4	3	2	1	0	0	0	0	0	0	0	0	0	0
2	4	4	4	4	4	3	3	2	2	1	1	0	0	0	0	0
3	4	4	4	4	4	4	4	3	3	2	2	1	0	0	0	0

# Motion Adaptive Colour Plus And Control IC (MACPACIC) for PALplus

SAA4996H

**Table 23** Control6

ADDRESS (HEX)	R/W	BIT	NAME	FUNCTION
68	W	7	Interlace	0: incoming video signal is defined as 'non interlaced'
				1: incoming video signal is defined as 'interlaced'
		6	EnPreEvFld	0: EVEN_FIELD signal defined internally
				1: EVEN_FIELD signal defined by SNERT transmission: PreEvFld
		5	PreEvFld	0: incoming field is defined as 'Odd'
1: incoming field is defined as 'Even'				
4 to 0	X	no function		

**8 TEST****8.1 Boundary scan test**

Boundary Scan Test (BST) is supported. See boundary scan specification: "IEEE Standard 1149.1 - 1990, IEEE standard test access port and boundary scan architecture".

## 8.1.1 IDENTIFICATION CODES

The PALplus ICs MACPACIC and VERIC are equipped with BST identification registers. The identification codes and their meaning are shown in Tables 24 and 25.

**Table 24** Identification codes

IC	VERSION	COMPONENT	MANUFACTURER	FIXED	IDENTIFICATION
	3322	22222 22211 11111 1	11000000000	0	–
	1098	76543 21098 76543 2	10987654321	0	–
MACPACIC	0001	01101 00001 00011 0	00000010101	1	1684602B
VERIC	0001	10110 00101 10010 0	00000010101	1	1B16402B

**Table 25** Code parts

BITS	NAME	DESCRIPTION
31 to 28	version number	start with 1 and increment every redesign
27 to 12	component	first 3 characters of name
11 to 1	manufacturer	JEDEC code for PHILIPS
0	fixed	1

# Motion Adaptive Colour Plus And Control IC (MACPACIC) for PALplus

SAA4996H

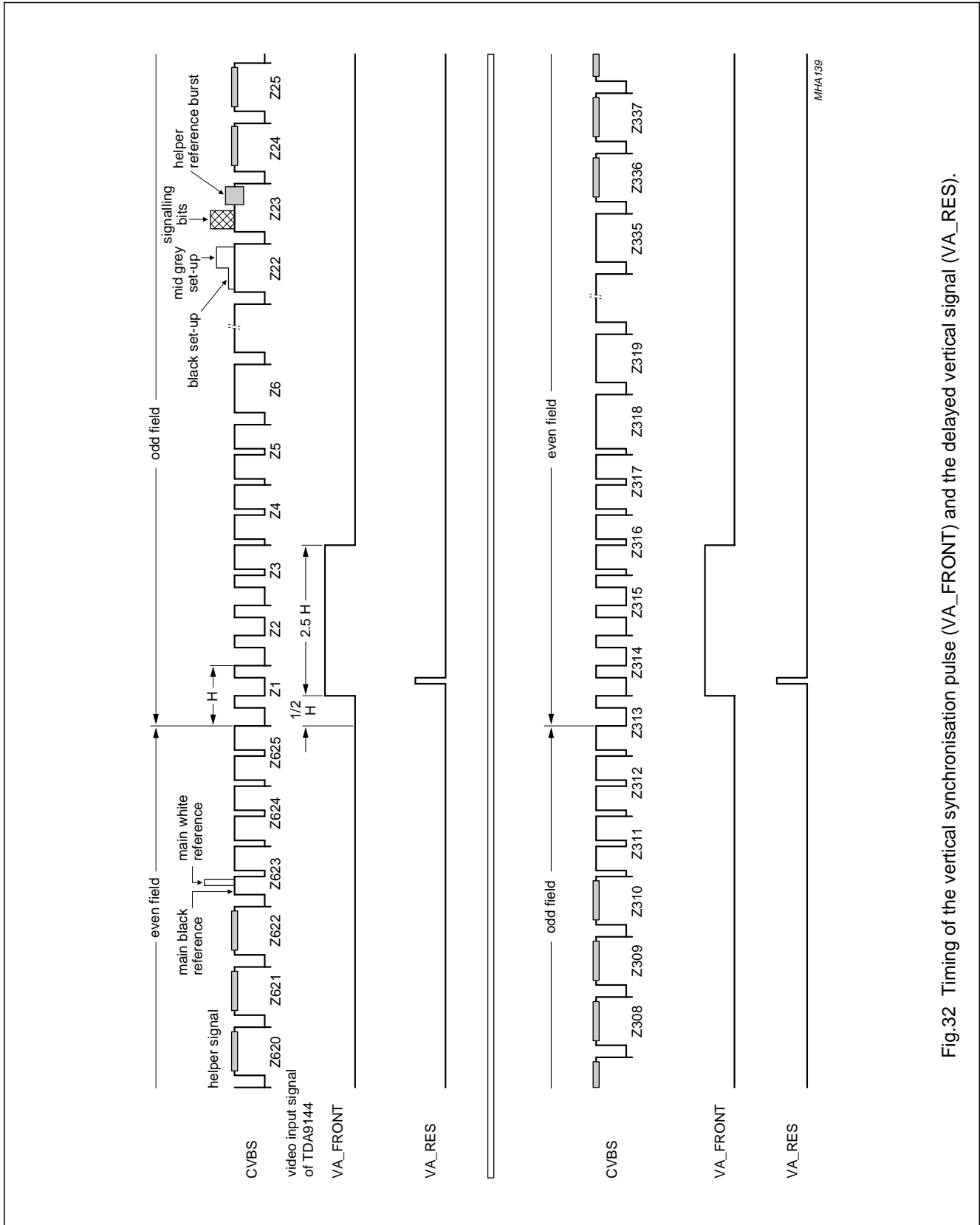
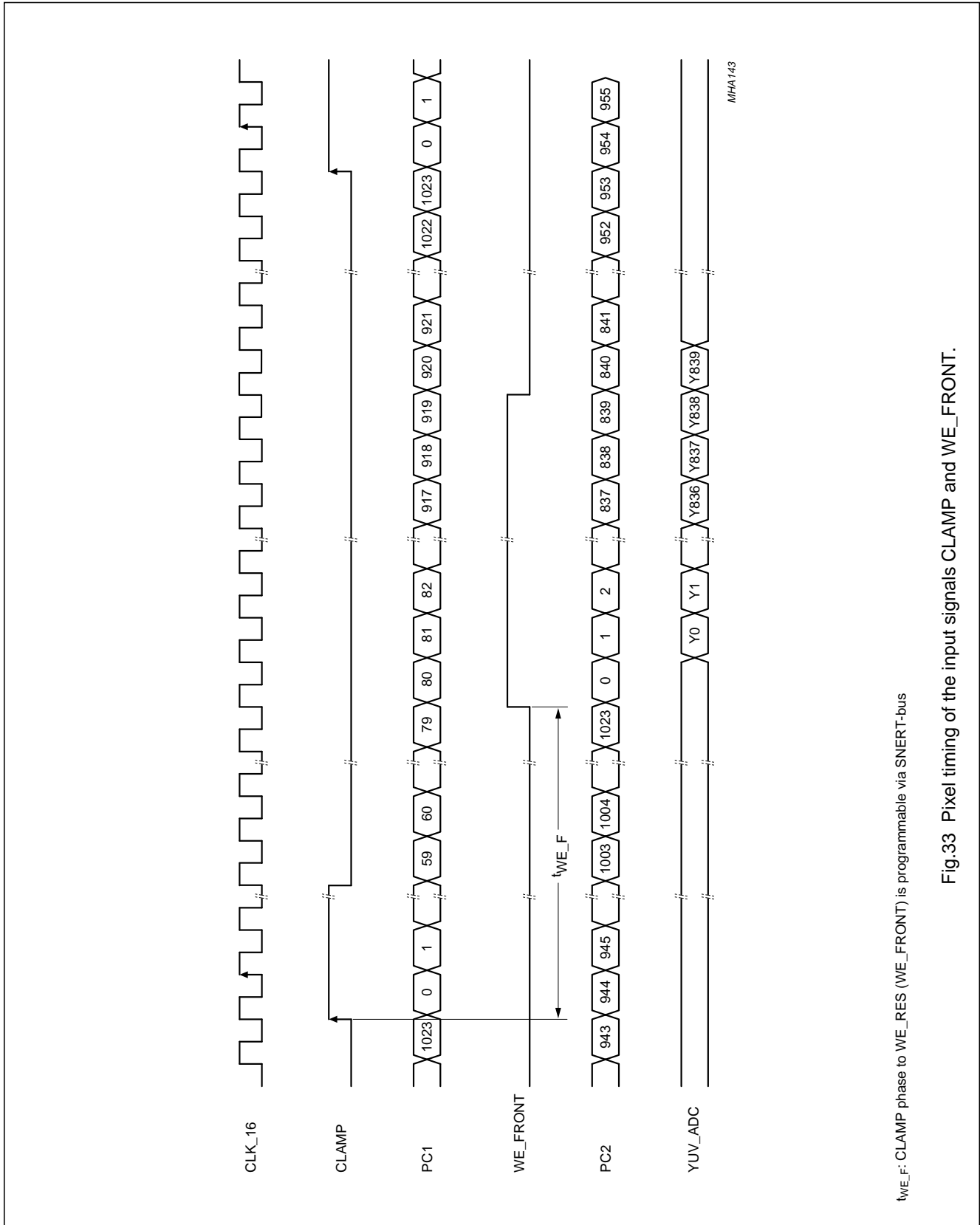

Fig.32 Timing of the vertical synchronisation pulse (VA\_FRONT) and the delayed vertical signal (VA\_RES).

Motion Adaptive Colour Plus And Control IC (MACPACIC) for PALplus

SAA4996H



$t_{WE\_F}$ : CLAMP phase to WE\_RES (WE\_FRONT) is programmable via SNERT-bus

Fig.33 Pixel timing of the input signals CLAMP and WE\_FRONT.

Motion Adaptive Colour Plus And Control  
IC (MACPACIC) for PALplus

SAA4996H

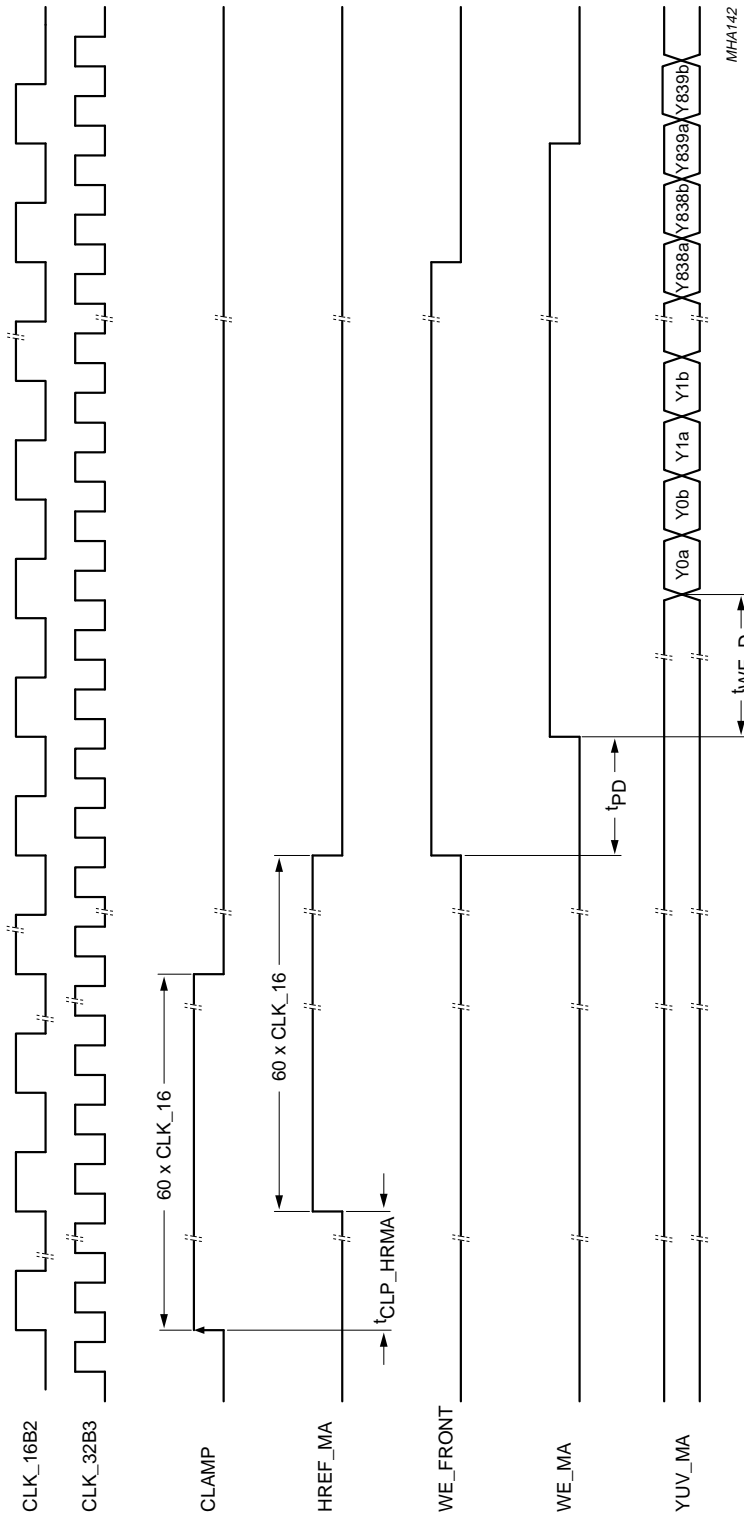

$t_{\text{CLP\_HRMA}}$ : delay CLAMP to HREF\_MA,  $2 \times \text{CLK}_{16B2}$   
 $t_{\text{PD}}$ : processing delay  
 $t_{\text{WE\_D}}$ : data write enable delay

Fig.34 Pixel timing of the output signals HREF\_MA and WE\_MA (full PALplus module and stand-alone MACPACIC).

Motion Adaptive Colour Plus And Control  
IC (MACPACIC) for PALplus

SAA4996H

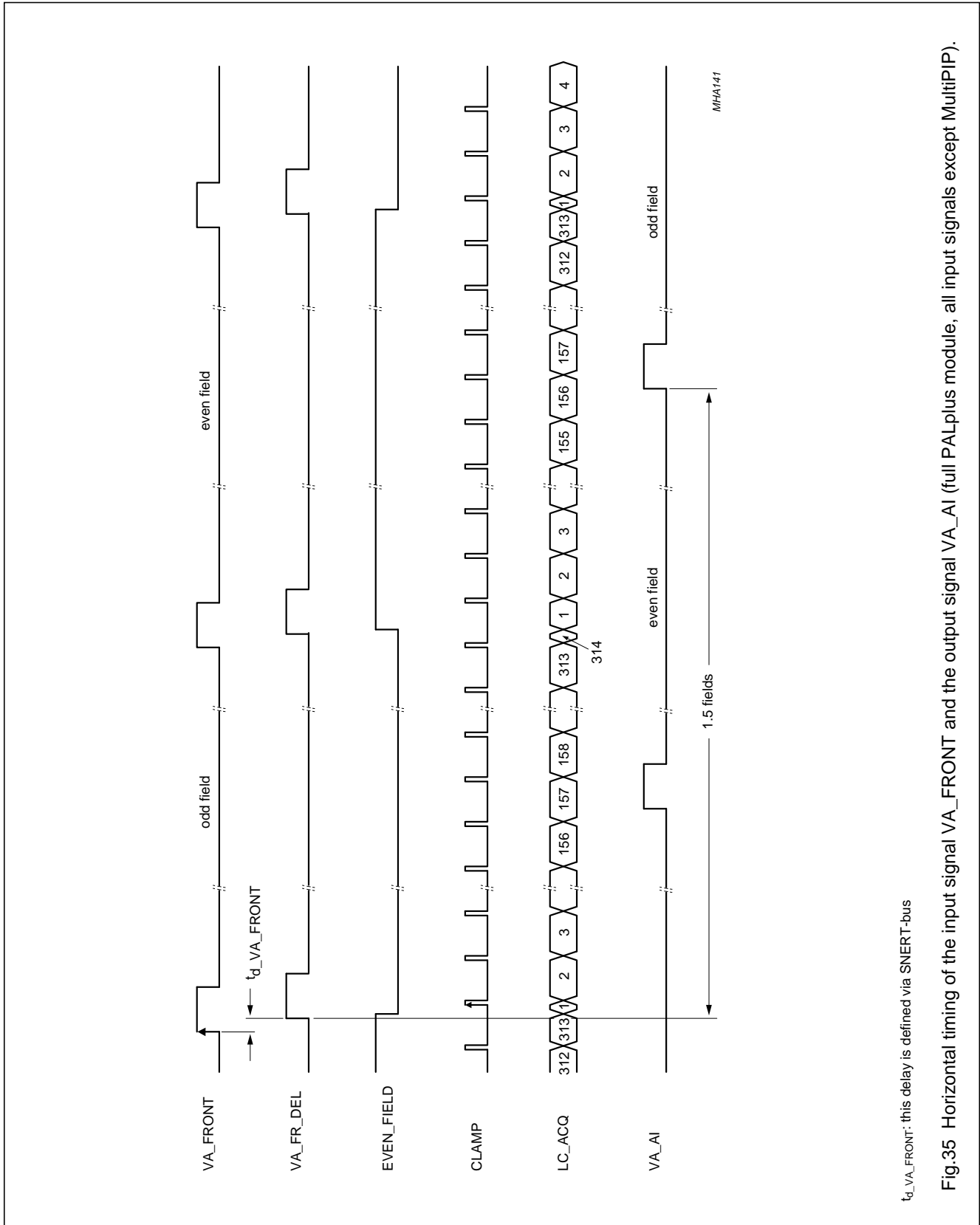

$t_{d\_VA\_FRONT}$ : this delay is defined via SNERT-bus

Fig.35 Horizontal timing of the input signal VA\_FRONT and the output signal VA\_AI (full PALplus module, all input signals except MultiPIP).



Motion Adaptive Colour Plus And Control IC (MACPACIC) for PALplus

SAA4996H

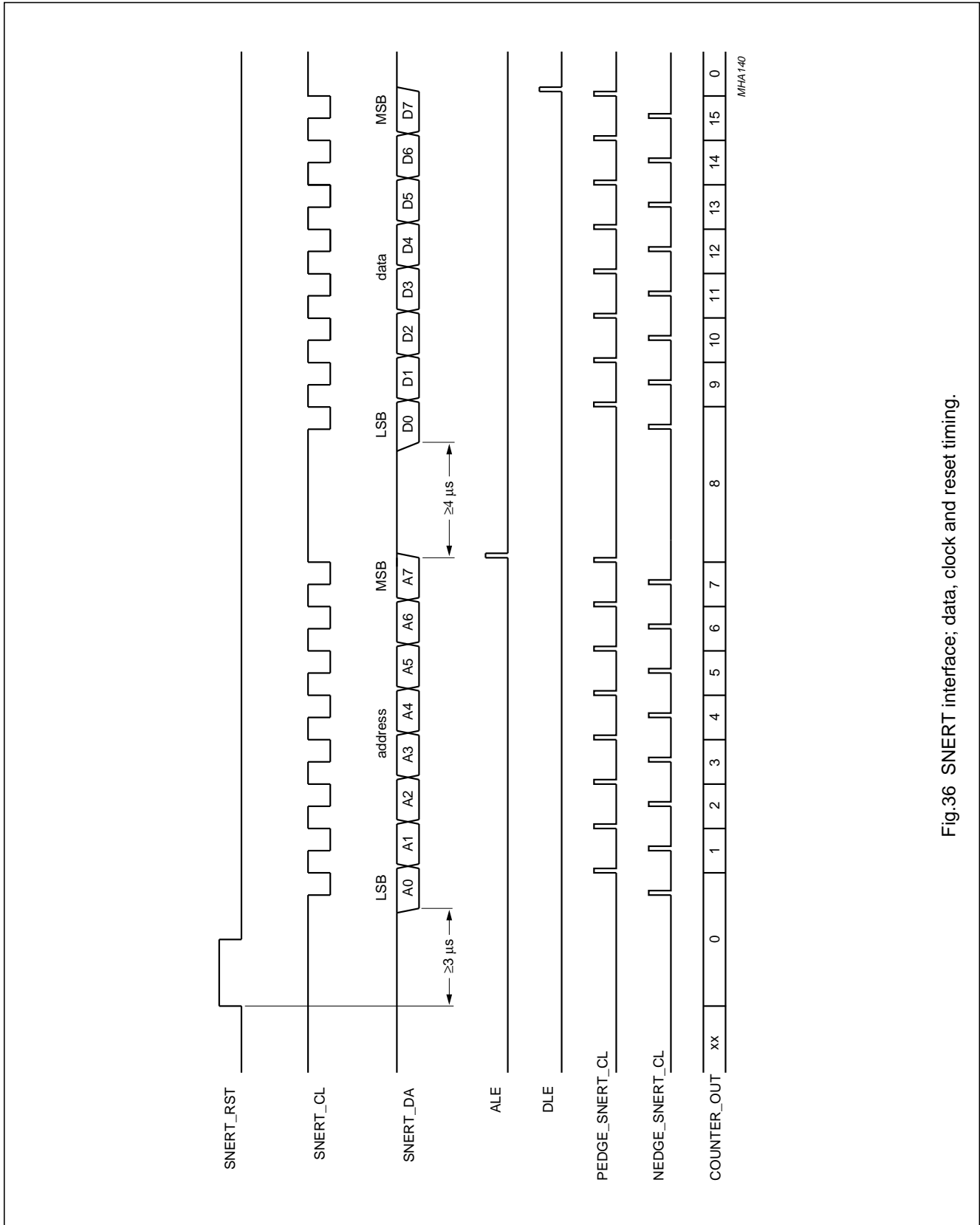

Fig.36 SNERT interface; data, clock and reset timing.

# Motion Adaptive Colour Plus And Control IC (MACPACIC) for PALplus

SAA4996H

## 9 DC CHARACTERISTICS

$T_j = 0$  to  $125$  °C unless otherwise specified.

SYMBOL	PARAMETER	CONDITIONS	MIN.	TYP.	MAX.	UNIT
<b>Supply</b>						
$V_{DD}$	supply voltage		4.75	5.00	5.25	V
$I_{DD}$	supply current		–	80	–	mA
$I_{DD(PD)}$	quiescent supply current	all inputs to $V_{DD}$ or $V_{SS}$	–	–	100	$\mu$ A
<b>Inputs</b>						
$V_{IL}$	LOW level input voltage		0	–	0.8	V
$V_{IH}$	HIGH level input voltage		2.0	–	$V_{DD}$	V
$I_I$	input current		–	–	1.0	$\mu$ A
<b>Outputs and 3-state</b>						
$V_{OL}$	LOW level output voltage	$I_O = 20 \mu$ A	–	–	0.1	V
$V_{OH}$	HIGH level output voltage	$I_O = 20 \mu$ A	$V_{DD} - 0.1$	–	–	V
<b>Outputs Y_TO_FM1, UV_TO_FM1, Y_MA, UV_MA, WE_MA, HREF_MA, UV_TO_FM4, EVEN_FIELD, INTPOL, FILM, RST_FM14, WE_FM1, RE_FM1, WE_FM4, RE_FM4 and CLK_16B1</b>						
$I_{OL}$	LOW level output current	$V_O = 0.5$ V	4	–	–	mA
$I_{OH}$	HIGH level output current	$V_O = V_{DD} - 0.5$ V	4	–	–	mA
<b>Outputs CLK_32B1, CLK_32B2 and CLK_16B2</b>						
$I_{OL}$	LOW level output current	$V_O = 0.5$ V	8	–	–	mA
$I_{OH}$	HIGH level output current	$V_O = V_{DD} - 0.5$ V	8	–	–	mA
<b>Outputs CLK_32B3 and CLK_16B3</b>						
$I_{OL}$	LOW level output current	$V_O = 0.5$ V	12	–	–	mA
$I_{OH}$	HIGH level output current	$V_O = V_{DD} - 0.5$ V	12	–	–	mA
<b>3-state TDO_MA, SNERT_DA, VA_FRONT and VA_AI</b>						
$I_Z$	input current		–	–	10	$\mu$ A

Motion Adaptive Colour Plus And Control IC (MACPACIC) for PALplus

SAA4996H

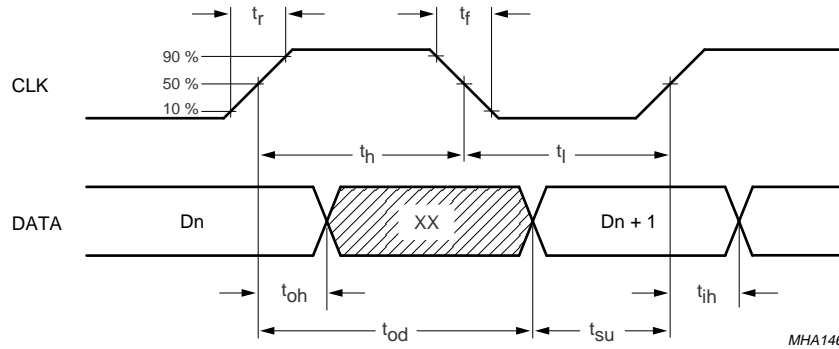

MHA146

Data input: CLK = CLK\_16.  
 Data output: CLK = CLK\_16 for stand-alone MACPACIC and CLK = CLK\_32 for full PALplus module.

Fig.37 Clock to data timing.

10 AC CHARACTERISTICS

T<sub>j</sub> = 0 to 125 °C unless otherwise specified.

SYMBOL	PARAMETER	CONDITIONS	MIN.	TYP.	MAX.	UNIT
<b>Clock CLK_32</b>						
T <sub>cy</sub>	cycle time		28.1	–	–	ns
t <sub>r</sub>	rise time		2	–	4	ns
t <sub>f</sub>	fall time		2	–	4	ns
t <sub>h</sub>	HIGH time		9.2	–	–	ns
t <sub>l</sub>	LOW time		9.2	–	–	ns
<b>Clock CLK_16</b>						
T <sub>CY</sub>	cycle time		56.2	–	–	ns
t <sub>r</sub>	rise time		2	–	4	ns
t <sub>f</sub>	fall time		2	–	4	ns
t <sub>h</sub>	HIGH time		20.5	–	–	ns
t <sub>l</sub>	LOW time		20.5	–	–	ns
<b>Input set-up time</b>						
t <sub>su</sub>	set-up time	all data inputs	6	–	–	ns
		CLK_16 w.r.t. CLK_32	4.5	–	–	ns

# Motion Adaptive Colour Plus And Control IC (MACPACIC) for PALplus

SAA4996H

SYMBOL	PARAMETER	CONDITIONS	MIN.	TYP.	MAX.	UNIT
<b>Input hold time</b>						
$t_{ih}$	input hold time	all data inputs	3	–	–	ns
		CLK_16 w.r.t. CLK_32	3.5	–	–	ns
<b>Outputs (<math>C_L = 15</math> pF)</b>						
CLK_16B1, CLK_16B2 AND CLK_16B3 (RISING)						
$t_{oh}$	hold time		6	–	–	ns
$t_{od}$	delay time		–	–	17	ns
CLK_16B1, CLK_16B2 AND CLK_16B3 (FALLING)						
$t_{oh}$	hold time		9	–	–	ns
$t_{od}$	delay time		–	–	24	ns
CLK_32B1, CLK_32B2 AND CLK_32B3 (RISING)						
$t_{oh}$	hold time		6	–	–	ns
$t_{od}$	delay time		–	–	17	ns
CLK_32B1, CLK_32B2 AND CLK_32B3 (FALLING)						
$t_{oh}$	hold time		6	–	–	ns
$t_{od}$	delay time		–	–	17	ns
<b>Outputs YUV_TO_FM1, RST_FM14, WE_FM1, RE_FM1, WE_FM4, RE_FM4, HREF_MA, WE_MA, VA_AI, VA_FRONT and YUV_MA (CLK_16; <math>C_L = 15</math> pF)</b>						
$t_{oh}$	hold time		12	–	–	ns
$t_{od}$	delay time		–	–	38	ns
<b>Outputs (CLK_32; <math>C_L = 15</math> pF; note 1)</b>						
YUV_MA						
$t_{oh}$	hold time		13	–	–	ns
$t_{od}$	delay time		–	–	39	ns
RSTW_FM23, WE_FM2 AND WE_FM3						
$t_{oh}$	hold time		12	–	–	ns
$t_{od}$	delay time		–	–	38	ns

**Note**

- 32 MHz output signals are related to the output clock signals CLK\_32B1 and CLK\_32B3.

**10.1 Clock buffers**

MACPACIC supplies the clocks for VERIC and the field memories on the PALplus module. Therefore the input clocks CLK\_16 and CLK\_32 are buffered and output as CLK\_16B1 to CLK\_16B3 and CLK\_32B1 to CLK\_32B3. The clock distribution is shown in Fig.5.

# Motion Adaptive Colour Plus And Control IC (MACPACIC) for PALplus

SAA4996H

## 11 LIST OF ABBREVIATIONS

**Table 26** Abbreviations used in document

SYMBOL	DESCRIPTION
ALE	Address Latch Enable
BB	Black Bands (above and below letter box picture)
BOH	Black Offset Hysteresis (see Table 20)
CLP_DIFF	Positive Edge of CLAMP Signal
DLE	Data Latch Enable
EnIRXR	Enable IRXR (see Table 12)
EnPreEvFld	Enable Preset Even Field (see Table 23)
FixHlpMain	Fix gain of Helper and Main Amplitude (see Table 17)
HlpM	Helper mode (see Table 11)
HlpRedThr	Helper Reduction Threshold (see Table 14)
H_RE/WE	Horizontal part of Read Enable/Write Enable signal
InvO/E	Invert Odd/Even
IRXR	Intelligent Residual Cross-Luminance Reduction
IrxrThr	IRXR Threshold (see Table 16)
IVericN	VERIC Identification (active LOW) (see Table 18)
LC_ACQ	Acquisition Line Counter
LC_DSP	Display Line Counter
MACP	Motion Adaptive Colour Plus
MacpOn	MACP on (see Table 11)
MacpYhThr	MACP Luminance Threshold (see Table 15)
MotVis	Motion Visibility (see Table 11)
Mpip	MultiPIP (see Table 12)
NmYI	Noise Dependent Luminance High-Pass Reduction (see Table 19)
PreEvFld	Preset Even Field (see Table 23)
Rha/Rhb	Helper Bandwidth and Amplitude Reduction (see Table 19)
SEL_SD_YL	Select Saturation Dependent Cross-Luminance Reduction (see Table 22)
VAA	Vertical Anti-Alias Filter (see Table 21)
VA_AI_DIFF	Positive Edge of VA_AI
VaDel	Delay of VA_FRONT
VA_FR_DEL	VA_FRONT Delayed
V_RE/WE	Vertical part of Read Enable/Write Enable signal
WeStrtH	Horizontal Start and Stop values for WE_MA (see Table 13 and Fig.31)
WeStpH	
WeStrtV	Vertical Start and Stop values for WE_MA (see Table 13 and Fig.31)
WeStpV	
XL	Cross-Luminance
Y_HP	Luminance High-Pass Component
Y_LP	Luminance Low-Pass Component

# Motion Adaptive Colour Plus And Control IC (MACPACIC) for PALplus

SAA4996H

## 12 PACKAGE OUTLINE

**QFP100: plastic quad flat package;**  
**100 leads (lead length 1.95 mm); body 14 x 20 x 2.7 mm; high stand-off height**

SOT317-1

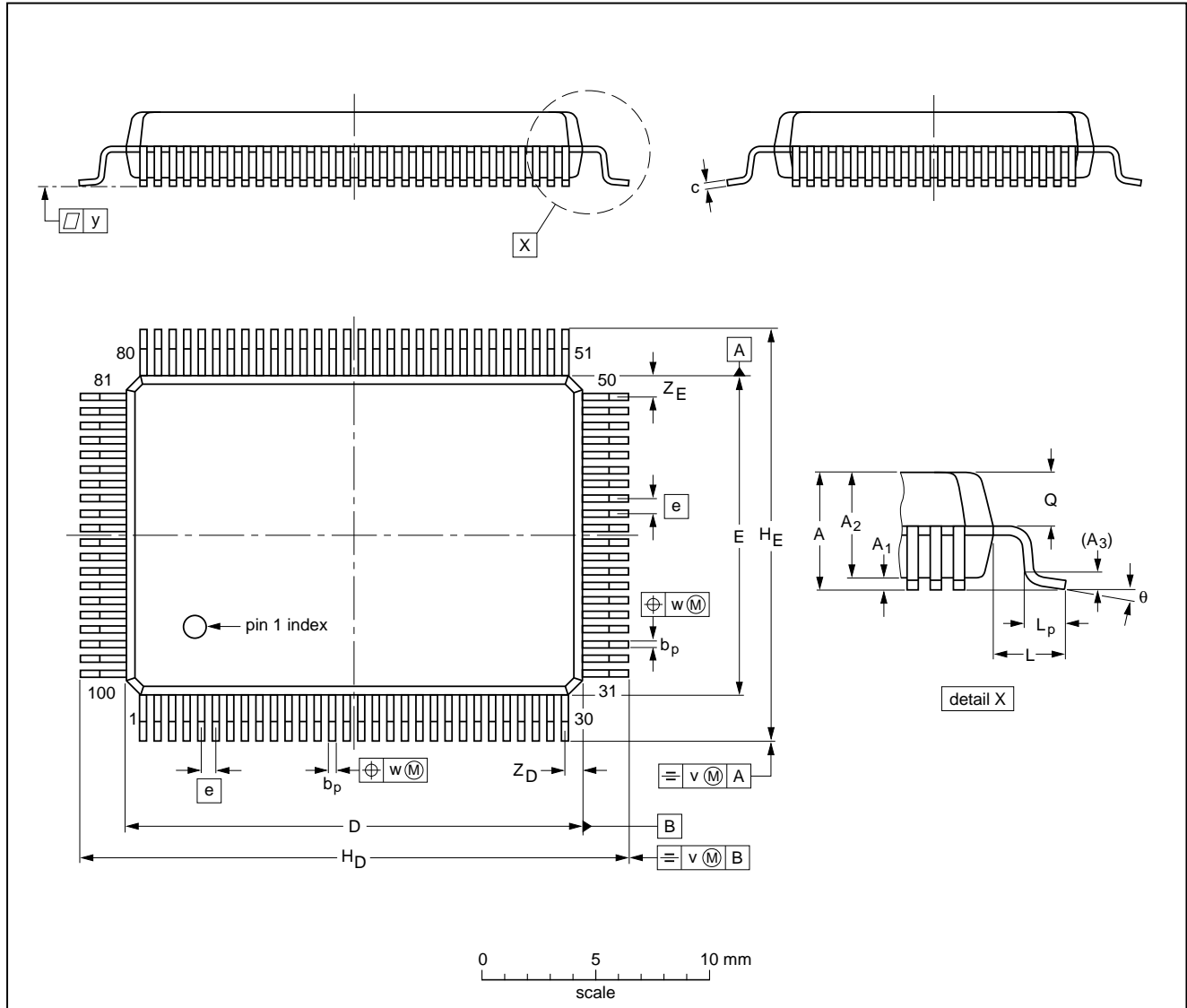

**DIMENSIONS (mm are the original dimensions)**

UNIT	A max.	A <sub>1</sub>	A <sub>2</sub>	A <sub>3</sub>	b <sub>p</sub>	c	D <sup>(1)</sup>	E <sup>(1)</sup>	e	H <sub>D</sub>	H <sub>E</sub>	L	L <sub>p</sub>	Q	v	w	y	Z <sub>D</sub> <sup>(1)</sup>	Z <sub>E</sub> <sup>(1)</sup>	θ
mm	3.3	0.36 0.10	2.87 2.57	0.25	0.40 0.25	0.25 0.13	20.1 19.9	14.1 13.9	0.65	24.2 23.6	18.2 17.6	1.95	1.0 0.6	1.43 1.23	0.2	0.15	0.1	0.8 0.4	1.0 0.6	7° 0°

**Note**

1. Plastic or metal protrusions of 0.25 mm maximum per side are not included.

OUTLINE VERSION	REFERENCES				EUROPEAN PROJECTION	ISSUE DATE
	IEC	JEDEC	EIAJ			
SOT317-1						92-11-17 95-02-04

## Motion Adaptive Colour Plus And Control IC (MACPACIC) for PALplus

SAA4996H

### 13 SOLDERING

#### 13.1 Introduction

There is no soldering method that is ideal for all IC packages. Wave soldering is often preferred when through-hole and surface mounted components are mixed on one printed-circuit board. However, wave soldering is not always suitable for surface mounted ICs, or for printed-circuits with high population densities. In these situations reflow soldering is often used.

This text gives a very brief insight to a complex technology. A more in-depth account of soldering ICs can be found in our "IC Package Databook" (order code 9398 652 90011).

#### 13.2 Reflow soldering

Reflow soldering techniques are suitable for all QFP packages.

The choice of heating method may be influenced by larger plastic QFP packages (44 leads, or more). If infrared or vapour phase heating is used and the large packages are not absolutely dry (less than 0.1% moisture content by weight), vaporization of the small amount of moisture in them can cause cracking of the plastic body. For more information, refer to the Drypack chapter in our "Quality Reference Handbook" (order code 9398 510 63011).

Reflow soldering requires solder paste (a suspension of fine solder particles, flux and binding agent) to be applied to the printed-circuit board by screen printing, stencilling or pressure-syringe dispensing before package placement.

Several techniques exist for reflowing; for example, thermal conduction by heated belt. Dwell times vary between 50 and 300 seconds depending on heating method. Typical reflow temperatures range from 215 to 250 °C.

Preheating is necessary to dry the paste and evaporate the binding agent. Preheating duration: 45 minutes at 45 °C.

#### 13.3 Wave soldering

Wave soldering is **not** recommended for QFP packages. This is because of the likelihood of solder bridging due to closely-spaced leads and the possibility of incomplete solder penetration in multi-lead devices.

If wave soldering cannot be avoided, the following conditions must be observed:

- **A double-wave (a turbulent wave with high upward pressure followed by a smooth laminar wave) soldering technique should be used.**
- **The footprint must be at an angle of 45° to the board direction and must incorporate solder thieves downstream and at the side corners.**

**Even with these conditions, do not consider wave soldering the following packages: QFP52 (SOT379-1), QFP100 (SOT317-1), QFP100 (SOT317-2), QFP100 (SOT382-1) or QFP160 (SOT322-1).**

During placement and before soldering, the package must be fixed with a droplet of adhesive. The adhesive can be applied by screen printing, pin transfer or syringe dispensing. The package can be soldered after the adhesive is cured.

Maximum permissible solder temperature is 260 °C, and maximum duration of package immersion in solder is 10 seconds, if cooled to less than 150 °C within 6 seconds. Typical dwell time is 4 seconds at 250 °C.

A mildly-activated flux will eliminate the need for removal of corrosive residues in most applications.

#### 13.4 Repairing soldered joints

Fix the component by first soldering two diagonally-opposite end leads. Use only a low voltage soldering iron (less than 24 V) applied to the flat part of the lead. Contact time must be limited to 10 seconds at up to 300 °C. When using a dedicated tool, all other leads can be soldered in one operation within 2 to 5 seconds between 270 and 320 °C.

# Motion Adaptive Colour Plus And Control IC (MACPACIC) for PALplus

SAA4996H

## 14 DEFINITIONS

<b>Data sheet status</b>	
Objective specification	This data sheet contains target or goal specifications for product development.
Preliminary specification	This data sheet contains preliminary data; supplementary data may be published later.
Product specification	This data sheet contains final product specifications.
<b>Limiting values</b>	
Limiting values given are in accordance with the Absolute Maximum Rating System (IEC 134). Stress above one or more of the limiting values may cause permanent damage to the device. These are stress ratings only and operation of the device at these or at any other conditions above those given in the Characteristics sections of the specification is not implied. Exposure to limiting values for extended periods may affect device reliability.	
<b>Application information</b>	
Where application information is given, it is advisory and does not form part of the specification.	

## 15 LIFE SUPPORT APPLICATIONS

These products are not designed for use in life support appliances, devices, or systems where malfunction of these products can reasonably be expected to result in personal injury. Philips customers using or selling these products for use in such applications do so at their own risk and agree to fully indemnify Philips for any damages resulting from such improper use or sale.



---

Motion Adaptive Colour Plus And Control  
IC (MACPACIC) for PALplus

---

SAA4996H

NOTES

---

Motion Adaptive Colour Plus And Control  
IC (MACPACIC) for PALplus

---

SAA4996H

NOTES

---

Motion Adaptive Colour Plus And Control  
IC (MACPACIC) for PALplus

---

SAA4996H

**NOTES**

# Philips Semiconductors – a worldwide company

**Argentina:** see South America

**Australia:** 34 Waterloo Road, NORTH RYDE, NSW 2113,  
Tel. +61 2 9805 4455, Fax. +61 2 9805 4466

**Austria:** Computerstr. 6, A-1101 WIEN, P.O. Box 213,  
Tel. +43 1 60 101, Fax. +43 1 60 101 1210

**Belarus:** Hotel Minsk Business Center, Bld. 3, r. 1211, Volodarski Str. 6,  
220050 MINSK, Tel. +375 172 200 733, Fax. +375 172 200 773

**Belgium:** see The Netherlands

**Brazil:** see South America

**Bulgaria:** Philips Bulgaria Ltd., Energoproject, 15th floor,  
51 James Bourchier Blvd., 1407 SOFIA,  
Tel. +359 2 689 211, Fax. +359 2 689 102

**Canada:** PHILIPS SEMICONDUCTORS/COMPONENTS,  
Tel. +1 800 234 7381

**China/Hong Kong:** 501 Hong Kong Industrial Technology Centre,  
72 Tat Chee Avenue, Kowloon Tong, HONG KONG,  
Tel. +852 2319 7888, Fax. +852 2319 7700

**Colombia:** see South America

**Czech Republic:** see Austria

**Denmark:** Prags Boulevard 80, PB 1919, DK-2300 COPENHAGEN S,  
Tel. +45 32 88 2636, Fax. +45 31 57 1949

**Finland:** Sinikalliontie 3, FIN-02630 ESPOO,  
Tel. +358 9 615800, Fax. +358 9 61580/xxx

**France:** 4 Rue du Port-aux-Vins, BP317, 92156 SURESNES Cedex,  
Tel. +33 1 40 99 6161, Fax. +33 1 40 99 6427

**Germany:** Hammerbrookstraße 69, D-20097 HAMBURG,  
Tel. +49 40 23 53 60, Fax. +49 40 23 536 300

**Greece:** No. 15, 25th March Street, GR 17778 TAVROS/ATHENS,  
Tel. +30 1 4894 339/239, Fax. +30 1 4814 240

**Hungary:** see Austria

**India:** Philips INDIA Ltd, Shivsagar Estate, A Block, Dr. Annie Besant Rd.  
Worli, MUMBAI 400 018, Tel. +91 22 4938 541, Fax. +91 22 4938 722

**Indonesia:** see Singapore

**Ireland:** Newstead, Clonskeagh, DUBLIN 14,  
Tel. +353 1 7640 000, Fax. +353 1 7640 200

**Israel:** RAPAC Electronics, 7 Kehilat Saloniki St, TEL AVIV 61180,  
Tel. +972 3 645 0444, Fax. +972 3 649 1007

**Italy:** PHILIPS SEMICONDUCTORS, Piazza IV Novembre 3,  
20124 MILANO, Tel. +39 2 6752 2531, Fax. +39 2 6752 2557

**Japan:** Philips Bldg 13-37, Kohnan 2-chome, Minato-ku, TOKYO 108,  
Tel. +81 3 3740 5130, Fax. +81 3 3740 5077

**Korea:** Philips House, 260-199 Itaewon-dong, Yongsan-ku, SEOUL,  
Tel. +82 2 709 1412, Fax. +82 2 709 1415

**Malaysia:** No. 76 Jalan Universiti, 46200 PETALING JAYA, SELANGOR,  
Tel. +60 3 750 5214, Fax. +60 3 757 4880

**Mexico:** 5900 Gateway East, Suite 200, EL PASO, TEXAS 79905,  
Tel. +9-5 800 234 7381

**Middle East:** see Italy

**Netherlands:** Postbus 90050, 5600 PB EINDHOVEN, Bldg. VB,  
Tel. +31 40 27 82785, Fax. +31 40 27 88399

**New Zealand:** 2 Wagener Place, C.P.O. Box 1041, AUCKLAND,  
Tel. +64 9 849 4160, Fax. +64 9 849 7811

**Norway:** Box 1, Manglerud 0612, OSLO,  
Tel. +47 22 74 8000, Fax. +47 22 74 8341

**Philippines:** Philips Semiconductors Philippines Inc.,  
106 Valero St. Salcedo Village, P.O. Box 2108 MCC, MAKATI,  
Metro MANILA, Tel. +63 2 816 6380, Fax. +63 2 817 3474

**Poland:** Ul. Lukiska 10, PL 04-123 WARSZAWA,  
Tel. +48 22 612 2831, Fax. +48 22 612 2327

**Portugal:** see Spain

**Romania:** see Italy

**Russia:** Philips Russia, Ul. Usatcheva 35A, 119048 MOSCOW,  
Tel. +7 095 247 9145, Fax. +7 095 247 9144

**Singapore:** Lorong 1, Toa Payoh, SINGAPORE 1231,  
Tel. +65 350 2538, Fax. +65 251 6500

**Slovakia:** see Austria

**Slovenia:** see Italy

**South Africa:** S.A. PHILIPS Pty Ltd., 195-215 Main Road Martindale,  
2092 JOHANNESBURG, P.O. Box 7430 Johannesburg 2000,  
Tel. +27 11 470 5911, Fax. +27 11 470 5494

**South America:** Rua do Rocio 220, 5th floor, Suite 51,  
04552-903 São Paulo, SÃO PAULO - SP, Brazil,  
Tel. +55 11 821 2333, Fax. +55 11 829 1849

**Spain:** Balmes 22, 08007 BARCELONA,  
Tel. +34 3 301 6312, Fax. +34 3 301 4107

**Sweden:** Kottbygatan 7, Akalla, S-16485 STOCKHOLM,  
Tel. +46 8 632 2000, Fax. +46 8 632 2745

**Switzerland:** Allmendstrasse 140, CH-8027 ZÜRICH,  
Tel. +41 1 488 2686, Fax. +41 1 481 7730

**Taiwan:** PHILIPS TAIWAN Ltd., 23-30F, 66,  
Chung Hsiao West Road, Sec. 1, P.O. Box 22978,  
TAIPEI 100, Tel. +886 2 382 4443, Fax. +886 2 382 4444

**Thailand:** PHILIPS ELECTRONICS (THAILAND) Ltd.,  
209/2 Sanpavuth-Bangna Road Prakanong, BANGKOK 10260,  
Tel. +66 2 745 4090, Fax. +66 2 398 0793

**Turkey:** Talatpasa Cad. No. 5, 80640 GÜLTEPE/ISTANBUL,  
Tel. +90 212 279 2770, Fax. +90 212 282 6707

**Ukraine:** PHILIPS UKRAINE, 4 Patrice Lumumba str., Building B, Floor 7,  
252042 KIEV, Tel. +380 44 264 2776, Fax. +380 44 268 0461

**United Kingdom:** Philips Semiconductors Ltd., 276 Bath Road, Hayes,  
MIDDLESEX UB3 5BX, Tel. +44 181 730 5000, Fax. +44 181 754 8421

**United States:** 811 East Arques Avenue, SUNNYVALE, CA 94088-3409,  
Tel. +1 800 234 7381

**Uruguay:** see South America

**Vietnam:** see Singapore

**Yugoslavia:** PHILIPS, Trg N. Pasica 5/v, 11000 BEOGRAD,  
Tel. +381 11 625 344, Fax. +381 11 635 777

**For all other countries apply to:** Philips Semiconductors, Marketing & Sales Communications,  
Building BE-p, P.O. Box 218, 5600 MD EINDHOVEN, The Netherlands, Fax. +31 40 27 24825

**Internet:** <http://www.semiconductors.philips.com>

© Philips Electronics N.V. 1996

SCA52

All rights are reserved. Reproduction in whole or in part is prohibited without the prior written consent of the copyright owner.

The information presented in this document does not form part of any quotation or contract, is believed to be accurate and reliable and may be changed without notice. No liability will be accepted by the publisher for any consequence of its use. Publication thereof does not convey nor imply any license under patent- or other industrial or intellectual property rights.

Printed in The Netherlands

537021/1200/01/pp60

Date of release: 1996 Oct 28

Document order number: 9397 750 01434

*Let's make things better.*

**Philips  
Semiconductors**



**PHILIPS**