

TL507C, TL507I ANALOG-TO-DIGITAL CONVERTER

SLAS041 – OCTOBER 1979 – REVISED OCTOBER 1988

- Low Cost
- 7-Bit Resolution
- Monotonicity Over Entire A/D Conversion Range
- Ratiometric Conversion
- Conversion Speed . . . Approximately 1 ms
- Single-Supply Operation . . . Either Unregulated 8-V to 18-V (V_{CC2} Input) or Regulated 3.5-V to 6-V (V_{CC1} Input)
- I²L Technology
- Power Consumption at 5 V . . . 25 mW Typ
- Regulated 5.5-V Output (≤ 1 mA)

description

The TL507 is a low-cost single-slope analog-to-digital converter designed to convert analog input voltages between $0.25 V_{CC1}$ and $0.75 V_{CC1}$ into a pulse-width-modulated output code. The device contains a 7-bit synchronous counter, a binary weighted resistor ladder network, an operational amplifier, two comparators, a buffer amplifier, an internal regulator, and necessary logic circuitry. Integrated-injection logic (I²L) technology makes it possible to offer this complex circuit at low cost in a small dual-in-line 8-pin package.

In continuous operation, conversion speeds of up to 1000 conversions per second are possible. The TL507 requires external signals for CLK, RESET, and ENABLE. Versatility and simplicity of operation, coupled with low cost, makes this converter especially useful for a wide variety of applications.

The TL507C is characterized for operation from 0°C to 70°C, and the TL507I is characterized for operation from -40°C to 85°C.

P PACKAGE
(TOP VIEW)

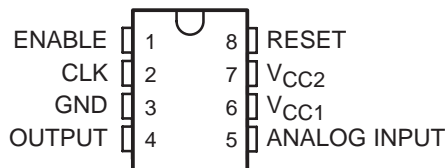

FUNCTION TABLE

ANALOG INPUT CONDITION	ENABLE	OUTPUT
X	L [†]	H
$V_I < 200$ mV	H	L
$V_{ramp} > V_I > 200$ mV	H	H
$V_I > V_{ramp}$	H	L

[†] Low level on enable also inhibits the reset function. H = high level, L = low level, X = irrelevant

A high level on RESET clears the counter to zero, which sets the internal ramp to $0.75 V_{CC}$. Internal pull-down resistors keep RESET and ENABLE low when not connected.

TL507C, TL507I ANALOG-TO-DIGITAL CONVERTER

SLAS041 – OCTOBER 1979 – REVISED OCTOBER 1988

functional block diagram (positive logic)

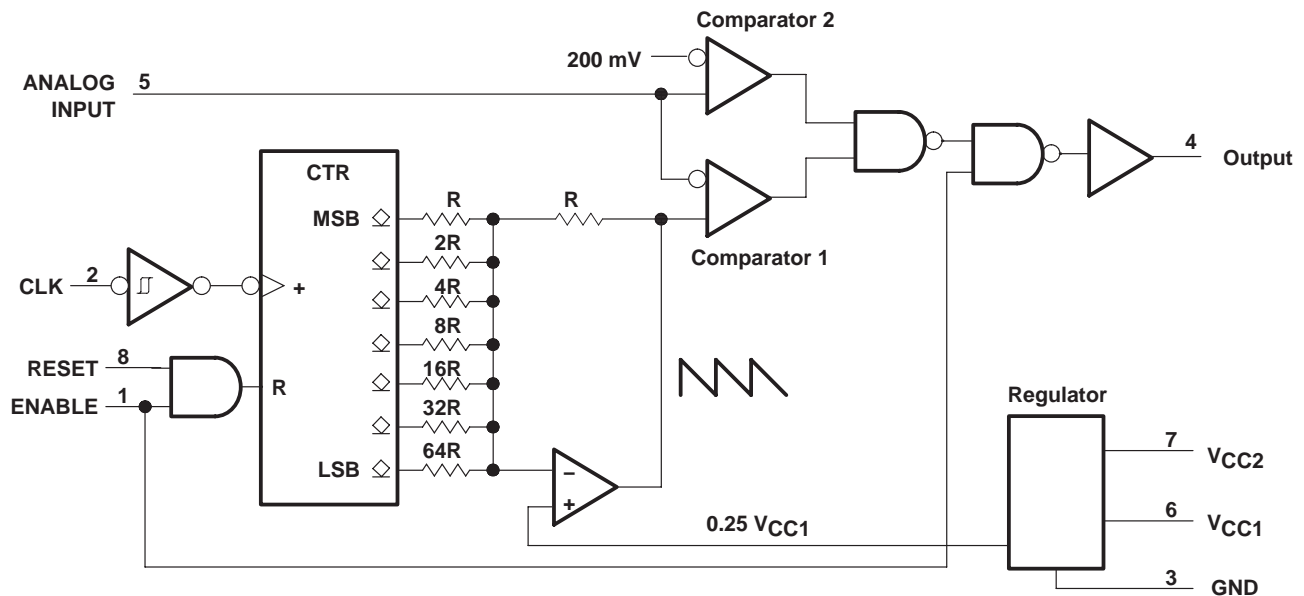

◇ indicates an n-p-n open-collector output.

schematics of inputs and outputs

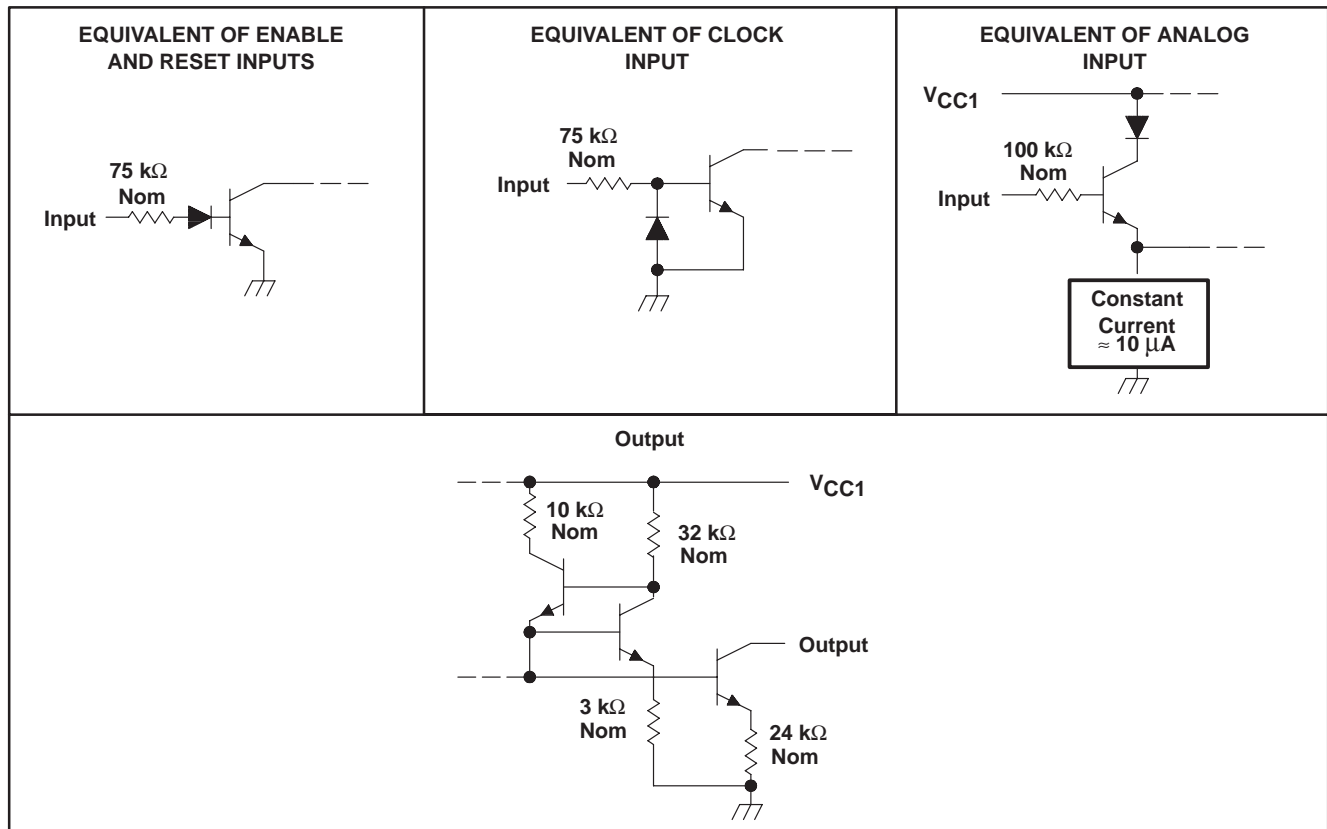

TL507C, TL507I ANALOG-TO-DIGITAL CONVERTER

SLAS041 – OCTOBER 1979 – REVISED OCTOBER 1988

absolute maximum ratings over operating free-air temperature range (unless otherwise noted)

Supply voltage, V_{CC1} (see Note 1)	6.5 V
Supply voltage, V_{CC2}	20 V
Input voltage at analog input	6.5 V
Input voltage at ENABLE, CLK, and RESET	20 V
On-state output voltage	6 V
Off-state output voltage	20 V
Continuous total dissipation at (or below) 25°C free-air temperature (see Note 2)	1000 mW
Operating free-air temperature range: TL507C	0 to 70°C
TL507I	–40°C to 85°C
Storage temperature range	–65°C to 150°C
Lead temperature 1,6 mm (1/16 inch) from case for 10 seconds	260°C

- NOTES: 1. Voltage values are with respect to network ground terminal unless otherwise noted.
 2. For operation above 25°C free-air temperature, derate linearly to 520 mW at 85°C at the rate of 8.0 mW/°C.

recommended operating conditions

	MIN	NOM	MAX	UNIT
Supply voltage, V_{CC1}	3.5	5	6	V
Supply voltage, V_{CC2}	8	15	18	V
Input voltage at ANALOG INPUT	0		5.5	V
Input voltage at ENABLE, CLK, and RESET			±18	V
High-level input voltage, V_{IH} , RESET and ENABLE	2			V
Low-level input voltage, V_{IL} , RESET and ENABLE			0.8	V
On-state output voltage			5.5	V
Off-state output voltage			1.8	V
Clock frequency, f_{clock}	0	125	150	kHz

electrical characteristics over recommended operating free-air temperature range, $V_{CC1} = V_{CC2} = 5\text{ V}$ (unless otherwise noted)

regular section

PARAMETER	TEST CONDITIONS	MIN	TYP†	MAX	UNIT
V_{CC1} Supply voltage (output)	$V_{CC2} = 10\text{ V to }18\text{ V}$, $I_{CC1} = 0\text{ to }-1\text{ mA}$	5	5.5	6	V
I_{CC1} Supply current	$V_{CC1} = 5\text{ V}$, V_{CC2} open		5	8	mA
I_{CC2} Supply current	$V_{CC2} = 15\text{ V}$, V_{CC1} open		7	10	mA

inputs

PARAMETER	TEST CONDITIONS	MIN	TYP†	MAX	UNIT	
V_{T+} Positive-going threshold voltage‡	CLK			4.5	V	
V_{T-} Negative-going threshold voltage‡			0.4		V	
V_{hys} Hysteresis ($V_{T+} - V_{T-}$)		2	2.6	4	V	
I_{IH} High-level input current	RESET, ENABLE, and CLK	$V_I = 2.4\text{ V}$	17	35	μA	
I_{IL} Low-level input current		$V_I = 18\text{ V}$	130	220	320	μA
I_I Analog input current		$V_I = 0$		±10	μA	
		$V_I = 4\text{ V}$	10	300	nA	

† All typical values are at $T_A = 25^\circ\text{C}$.
 ‡ These parameters are linear functions of V_{CC1} .



TL507C, TL507I

ANALOG-TO-DIGITAL CONVERTER

SLAS041 – OCTOBER 1979 – REVISED OCTOBER 1988

output section

PARAMETER		TEST CONDITIONS	MIN	TYP†	MAX	UNIT
I_{OH}	High-level output current	$V_{OH} = 18\text{ V}$		0.1	100	μA
I_{OL}	Low-level output current	$V_{OL} = 5.5\text{ V}$	5	10	15	mA
V_{OL}	Low-level output voltage	$I_{OL} = 1.6\text{ mA}$		80	400	mV

operating characteristics over recommended operating free-air temperature range, $V_{CC1} = V_{CC2} = 5.12\text{ V}$

PARAMETER		TEST CONDITIONS	MIN	TYP†	MAX	UNIT
Overall error					± 80	mV
Differential nonlinearity		See Figure 1			± 20	mV
Zero error‡		Binary count = 0			± 80	mV
Scale error		Binary count = 127			± 80	mV
Full scale input voltage‡		Binary count = 127	3.74	3.82	3.9	V
Propagation delay time from RESET or ENABLE				2		μs

† All typical values are at $T_A = 25^\circ\text{C}$.

‡ These parameters are linear functions of V_{CC1} .

definitions

zero error

The absolute value of the difference between the actual analog voltage at the 01H-to-00H transition and the ideal analog voltage at that transition.

overall error

The magnitude of the deviation from a straight line between the endpoints of the transfer function.

differential nonlinearity

The maximum deviation of an analog-value change associated with a 1-bit code change (1 clock pulse) from its theoretical value of 1 LSB.



PARAMETER MEASUREMENT INFORMATION

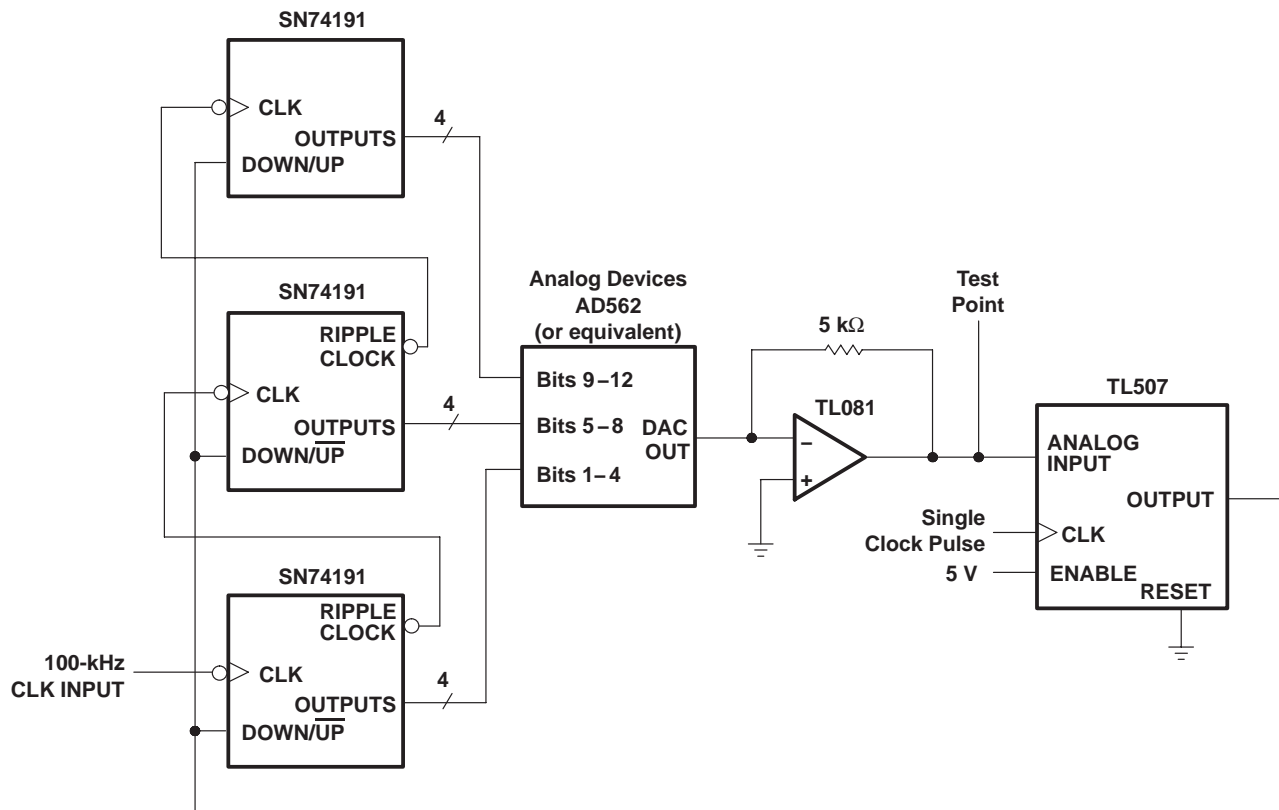

Figure 1. Monotonicity and Nonlinearity Test Circuit

TL507C, TL507I

ANALOG-TO-DIGITAL CONVERTER

SLAS041 – OCTOBER 1979 – REVISED OCTOBER 1988

PRINCIPLES OF OPERATION

The TL507 is a single-slope analog-to-digital converter. All single-slope converters are basically voltage-to-time or current-to-time converters. A study of the functional block diagram shows the versatility of the TL507.

An external clock signal is applied through a buffer to a negative-edge-triggered synchronous counter. Binary-weighted resistors from the counter are connected to an operational amplifier used as an adder. The operational amplifier generates a signal that ramps from $0.75 \cdot V_{CC1}$ down to $0.25 \cdot V_{CC1}$. Comparator 1 compares the ramp signal to the analog input signal. Comparator 2 functions as a fault defector. With the analog input voltage in the range $0.25 \cdot V_{CC1}$ to $0.75 \cdot V_{CC1}$, the duty cycle of the output signal is determined by the unknown analog input, as shown in Figure 2 and the Function Table.

For illustration, assume $V_{CC1} = 5.12 \text{ V}$,

$$0.25 \cdot V_{CC1} = 1.28 \text{ V}$$

$$1 \text{ binary count} = \frac{(0.75 - 0.25) V_{CC1}}{128} = 20 \text{ mV}$$

$$0.75 \cdot V_{CC1} - 1 \text{ count} = 3.82 \text{ V}$$

The output is an open-collector n-p-n transistor capable of withstanding up to 18 V in the off state. The output is current limited to the 8- to 12-mA range; however, care must be taken to ensure that the output does not exceed 5.5 V in the on state.

The voltage regulator section allows operation from either an unregulated 8- to 18-V V_{CC2} source or a regulated 3.5- to 6-V V_{CC1} source. Regardless of which external power source is used, the internal circuitry operates at V_{CC1} . When operating from a V_{CC1} source, V_{CC2} may be connected to V_{CC1} or left open. When operating from a V_{CC2} source, V_{CC1} can be used as a reference voltage output.

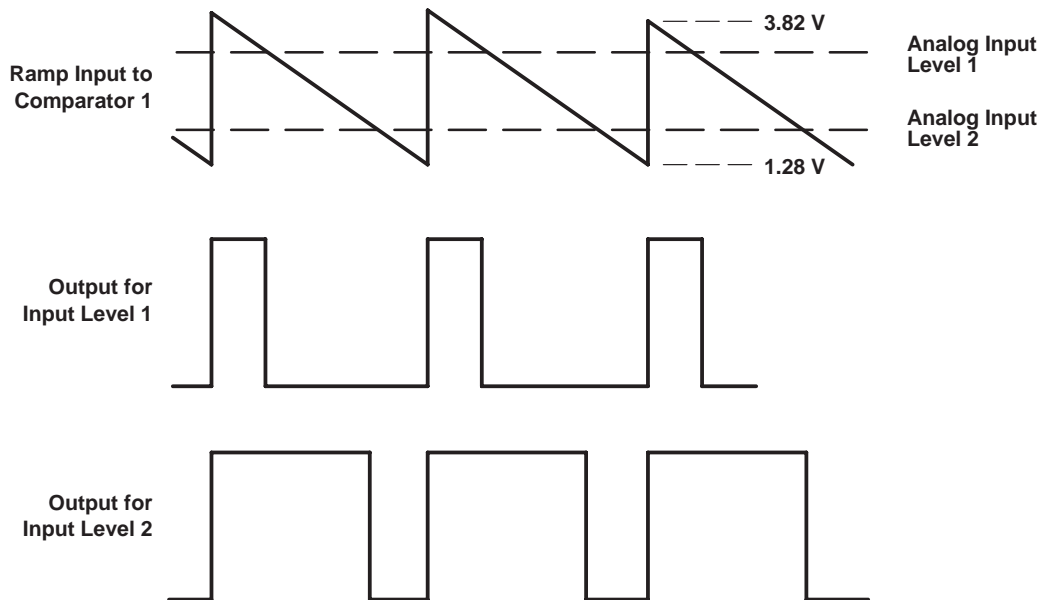

Figure 2



IMPORTANT NOTICE

Texas Instruments Incorporated and its subsidiaries (TI) reserve the right to make corrections, modifications, enhancements, improvements, and other changes to its products and services at any time and to discontinue any product or service without notice. Customers should obtain the latest relevant information before placing orders and should verify that such information is current and complete. All products are sold subject to TI's terms and conditions of sale supplied at the time of order acknowledgment.

TI warrants performance of its hardware products to the specifications applicable at the time of sale in accordance with TI's standard warranty. Testing and other quality control techniques are used to the extent TI deems necessary to support this warranty. Except where mandated by government requirements, testing of all parameters of each product is not necessarily performed.

TI assumes no liability for applications assistance or customer product design. Customers are responsible for their products and applications using TI components. To minimize the risks associated with customer products and applications, customers should provide adequate design and operating safeguards.

TI does not warrant or represent that any license, either express or implied, is granted under any TI patent right, copyright, mask work right, or other TI intellectual property right relating to any combination, machine, or process in which TI products or services are used. Information published by TI regarding third-party products or services does not constitute a license from TI to use such products or services or a warranty or endorsement thereof. Use of such information may require a license from a third party under the patents or other intellectual property of the third party, or a license from TI under the patents or other intellectual property of TI.

Reproduction of TI information in TI data books or data sheets is permissible only if reproduction is without alteration and is accompanied by all associated warranties, conditions, limitations, and notices. Reproduction of this information with alteration is an unfair and deceptive business practice. TI is not responsible or liable for such altered documentation. Information of third parties may be subject to additional restrictions.

Resale of TI products or services with statements different from or beyond the parameters stated by TI for that product or service voids all express and any implied warranties for the associated TI product or service and is an unfair and deceptive business practice. TI is not responsible or liable for any such statements.

TI products are not authorized for use in safety-critical applications (such as life support) where a failure of the TI product would reasonably be expected to cause severe personal injury or death, unless officers of the parties have executed an agreement specifically governing such use. Buyers represent that they have all necessary expertise in the safety and regulatory ramifications of their applications, and acknowledge and agree that they are solely responsible for all legal, regulatory and safety-related requirements concerning their products and any use of TI products in such safety-critical applications, notwithstanding any applications-related information or support that may be provided by TI. Further, Buyers must fully indemnify TI and its representatives against any damages arising out of the use of TI products in such safety-critical applications.

TI products are neither designed nor intended for use in military/aerospace applications or environments unless the TI products are specifically designated by TI as military-grade or "enhanced plastic." Only products designated by TI as military-grade meet military specifications. Buyers acknowledge and agree that any such use of TI products which TI has not designated as military-grade is solely at the Buyer's risk, and that they are solely responsible for compliance with all legal and regulatory requirements in connection with such use.

TI products are neither designed nor intended for use in automotive applications or environments unless the specific TI products are designated by TI as compliant with ISO/TS 16949 requirements. Buyers acknowledge and agree that, if they use any non-designated products in automotive applications, TI will not be responsible for any failure to meet such requirements.

Following are URLs where you can obtain information on other Texas Instruments products and application solutions:

Products

Amplifiers	amplifier.ti.com
Data Converters	dataconverter.ti.com
DSP	dsp.ti.com
Clocks and Timers	www.ti.com/clocks
Interface	interface.ti.com
Logic	logic.ti.com
Power Mgmt	power.ti.com
Microcontrollers	microcontroller.ti.com
RFID	www.ti-rfid.com
RF/IF and ZigBee® Solutions	www.ti.com/lprf

Applications

Audio	www.ti.com/audio
Automotive	www.ti.com/automotive
Broadband	www.ti.com/broadband
Digital Control	www.ti.com/digitalcontrol
Medical	www.ti.com/medical
Military	www.ti.com/military
Optical Networking	www.ti.com/opticalnetwork
Security	www.ti.com/security
Telephony	www.ti.com/telephony
Video & Imaging	www.ti.com/video
Wireless	www.ti.com/wireless

Mailing Address: Texas Instruments, Post Office Box 655303, Dallas, Texas 75265
Copyright © 2008, Texas Instruments Incorporated