

Monolithic Integrated Circuit

Description

The integrated circuit, U2841B, is designed as a single FM-IF-amplifier and demodulator for TV sound processing with SCART switches and AF control in bipolar technology.

Features

- IF input provided for operating with ceramic filters
- Minimum total harmonic distortion
- Low power consumption
- Operates alternatively with 5 V or 12 V supply voltage
- Demodulator provided for operating with ceramic resonator or coil
- SCART AF input / AF output
- Wide volume control range
- ESD protected

Block Diagram

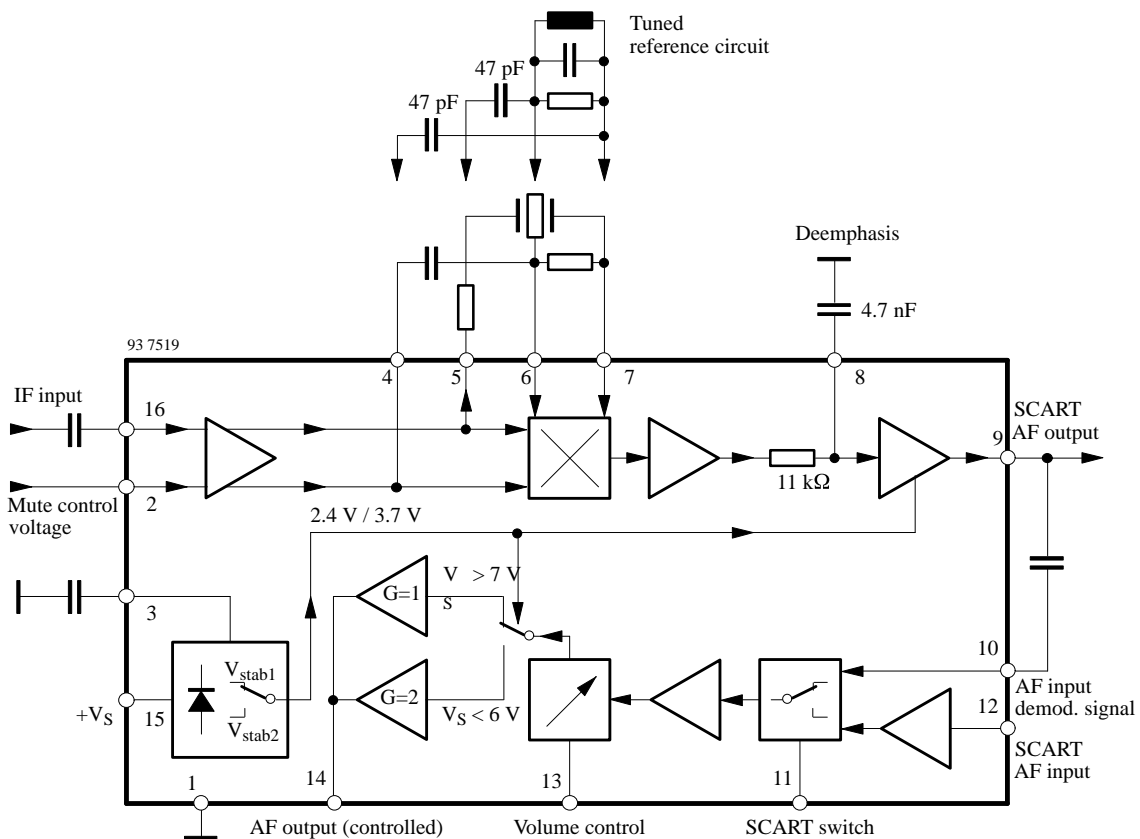
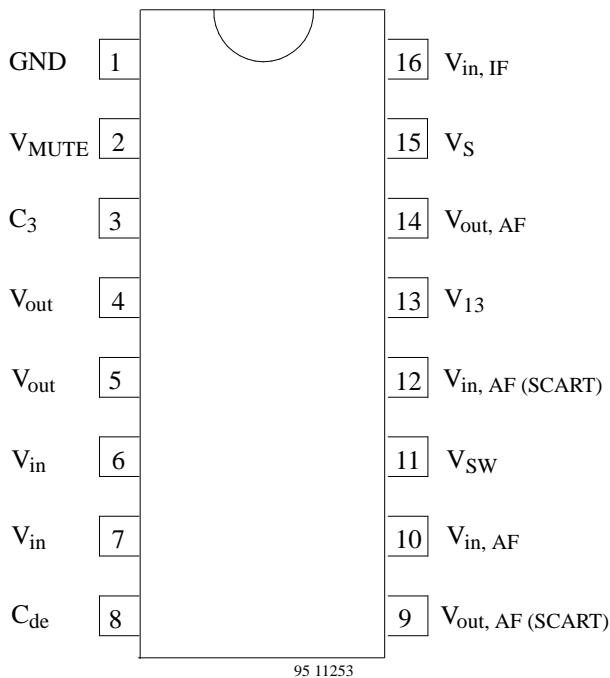

Figure 1.

Pin Description



Pin	Symbol	Function
1	GND	Ground
2	V_{MUTE}	Mute control voltage
3	C_3	Capacitor (internal reference voltage)
4, 5	V_{out}	Limiter amplifier output
6, 7	V_{in}	Reference circuit (demodulator)
8	C_{de}	Deemphasis
9	$V_{out, AF (SCART)}$	AF output (SCART)
10	$V_{in, AF}$	AF input (demodulated signal)
11	V_{SW}	SCART switch
12	$V_{in, AF (SCART)}$	AF input (SCART)
13	V_{13}	Volume control
14	$V_{out, AF}$	AF output, controlled
15	V_S	Supply voltage
16	$V_{in, IF}$	FM IF input

Circuit Description

The bipolar circuit U2841B contains the complete FM intercarrier sound processing (mono) with additional AF volume control, SCART switches and external mute control. The circuit operates alternatively with 5 V or 12 V supply voltage.

Circuit operation is as follows:

Through an external ceramic bandpass filter, which is tuned to the sound carrier frequency, the intercarrier signal is fed via a 9-stage limiting amplifier to the FM demodulator. This quadrature demodulator works alternatively with an external L-C reference circuit or with a ceramic resonator.

The AF signal is available at Pin 9 (AF output – SCART), and via the SCART switch and volume control at Pin 14

(AF output – controlled). The demodulated AF signal at Pin 10 (AF input – demodulator signal) or an external signal at Pin 12 (AF input – SCART) will be selected by the SCART switch and supplied to the volume control.

In dependence on supply voltage the gain of controlled AF output (Pin 14) will be switched over:

- Supply voltage range $4.7 < V_S < 6.0$ V:
gain of AF output amplifier $G = 2$.
In this case the AF input signal at Pin 12 (SCART input) must be reduced by a voltage divider.
- Supply voltage range $7.0 < V_S < 12.5$ V:
gain of AF output amplifier $G = 1$.

Absolute Maximum Ratings

Reference point Pin 1, unless otherwise specified

Parameters	Symbol	Value	Unit
Supply voltage Pin 15	V_S	12.5	V
Supply current Pin 15	I_S	33	mA
External voltage Pins 2, 3, 4, 5, 7, 8, 9, 10, 12, 13, 14 and 16	V_{ext}	5	V
External voltage Pin 11	V_{ext}	V_S	V
Junction temperature	T_j	125	°C
Ambient temperature	T_{amb}	-25 to +85	°C
Storage temperature	T_{stg}	-25 to +125	°C

Thermal Resistance

Parameters	Symbol	Value	Unit
Junction ambient	R_{thJA}	90	K/W

Electrical Characteristics

$T_{amb} = 25^\circ\text{C}$, $V_S = 12\text{ V}$, reference point Pin 1, unless otherwise specified

Parameters	Test Conditions / Pins	Symbol	Min	Typ	Max	Unit
Supply voltage	Pin 15	V_S	4.7 7.0		6.0 12.5	V
Supply current	$V_S < 6\text{ V}$ Pin 15 $V_S > 7\text{ V}$	I_S		22 28		mA
IF frequency range	Pin 16	f_{IF}	3.5		12	MHz
DC output voltage	$V_S < 6\text{ V}$ Pins 9 and 14 $V_S > 7\text{ V}$	V_{DC}		2.4 3.7		V
AF output voltage	$f_{mod} = 1\text{ kHz}$ Pins 9 and 14 $\Delta_f = \pm 30\text{ kHz}$	V_{AF}		600		mV
Total harmonic distortion	$f_{mod} = 1\text{ kHz}$ Pins 9 and 14 $\Delta_f = \pm 30\text{ kHz}$	T_{HD}		0.5		%
Input limiting voltage	AF output sign -3 dB Pin 16	V_{in}		150		μV_{eff}
AM suppression	$V_{in} = 20\text{ mV}$, Pins 4 and 5 $f = 5.5\text{ MHz}$ $f_{mod} = 1\text{ kHz}$ Reference signal: $\Delta_f = \pm 30\text{ kHz}$ Test signal: $m = 30\%$	G_{AM}		60		dB
Input resistance	Pin 16	R_{in}		820		Ω
Allowable external load resistor, AF output	Pins 9 and 14	R_L	3			k Ω
Control range AF volume control	$V_{13} = 0 - 4\text{ V}$ Pin 14	A		80		dB
Gain between SCART input and controlled AF output	$V_S < 6\text{ V}$ Pins 12 - 14 $V_S > 7\text{ V}$	G		6 0		dB

Parameters	Test Conditions / Pins	Symbol	Min	Typ	Max	Unit
Max. SCART input voltage	$V_S < 6\text{ V}$ Pins 10 and 12	$V_{in\ max}$	1			V_{eff}
	$V_S > 7\text{ V}$		2			
Max. AF output voltage (controlled output)	$V_S < 6\text{ V}$ Pins 10 and 12	$V_{AF\ max}$	1			V_{eff}
	$V_{13} = 4\text{ V}$		2			
	$V_S > 7\text{ V}$		2			
Control voltage (SCART switch)	Record Pin 11	V	0		2	V
	Play Pin 11		4		V_S	
Control voltage (MUTE switch)	Mute on Pin 2	V	0		2	V

Circuits

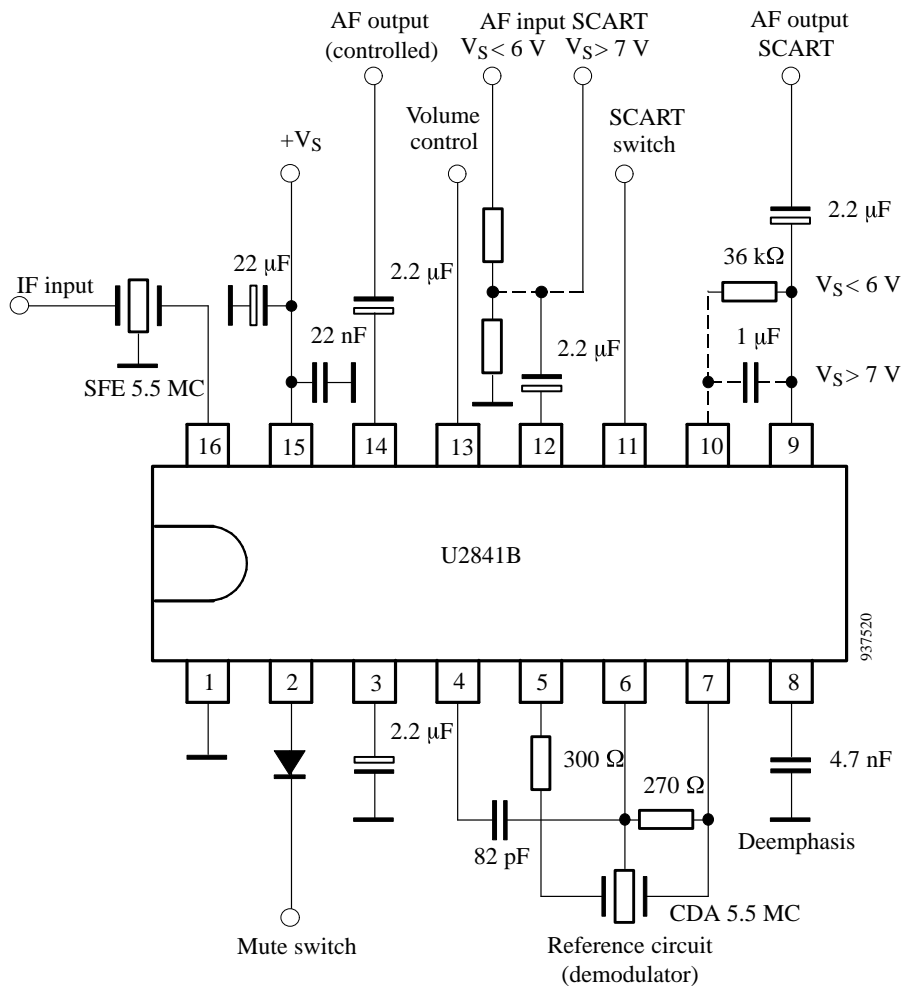

Figure 2. Test circuit

Internal Pin Circuit Diagrams

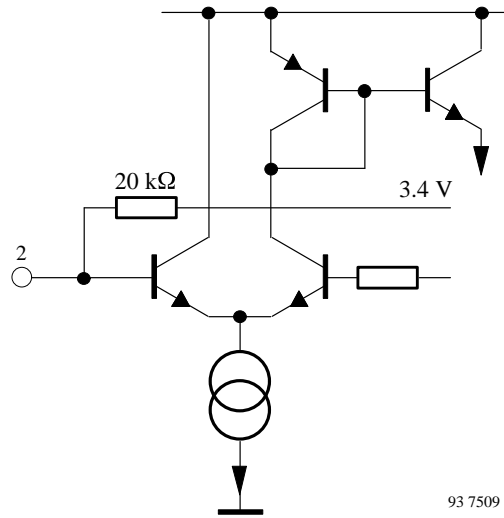

Figure 3. Pin 2: Mute switch

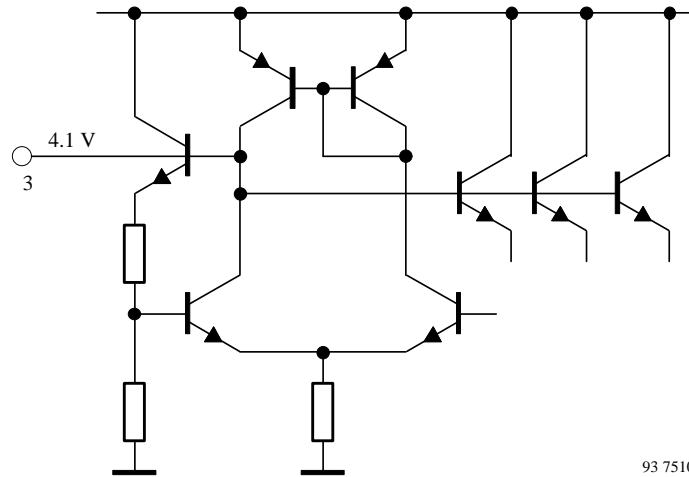

Figure 4. Pin 3: Internal reference voltage

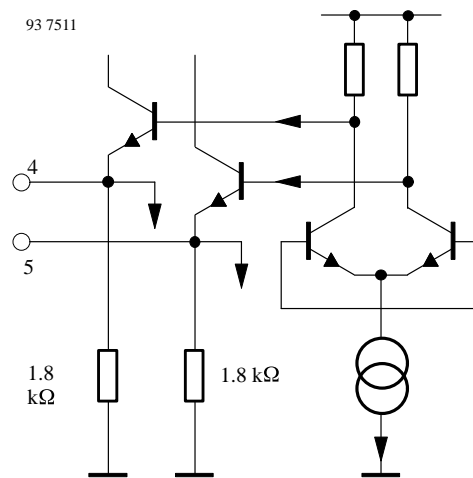

Figure 5. Pin 4, 5: Limiter amplifier output

Internal Pin Circuit Diagrams (continued)

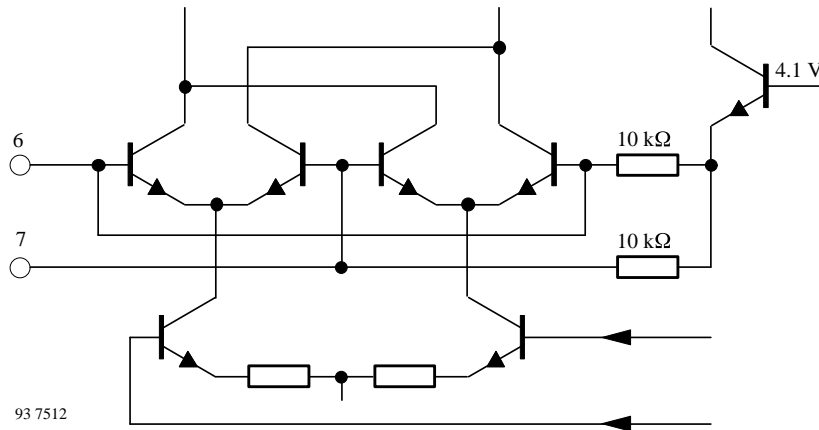

Figure 6. Pin 6, 7: Reference circuit, demodulator

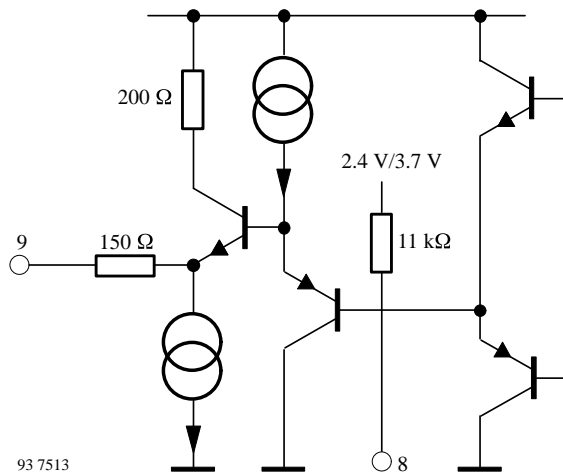

Figure 7. Pin 8, 9: Deemphasis and AF output (SCART)

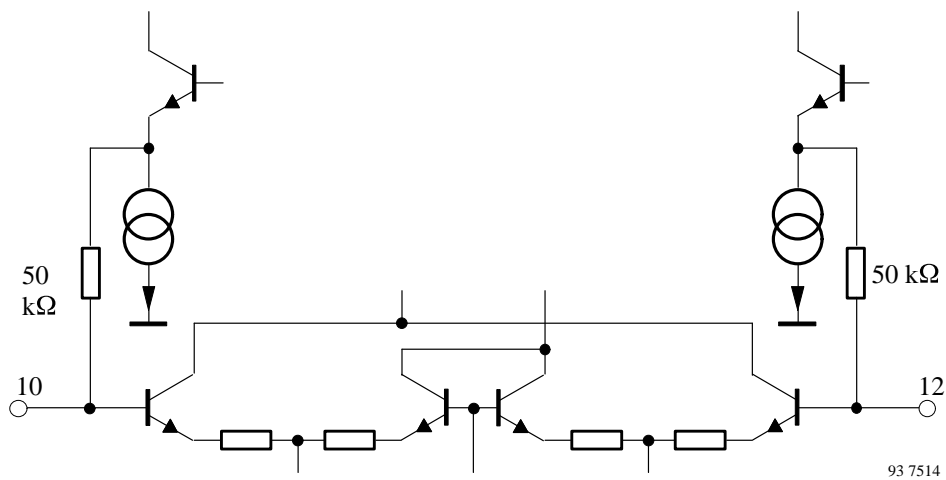

Figure 8. Pin 10, 12: AF input (demod. signal) and AF input (SCART)

Internal Pin Circuit Diagrams (continued)

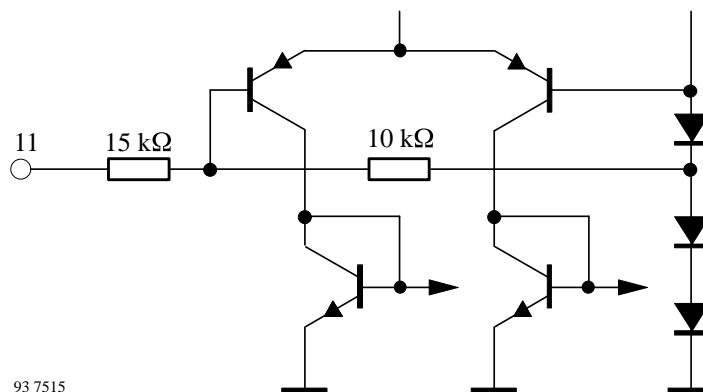

Figure 9. Pin 11: SCART switch

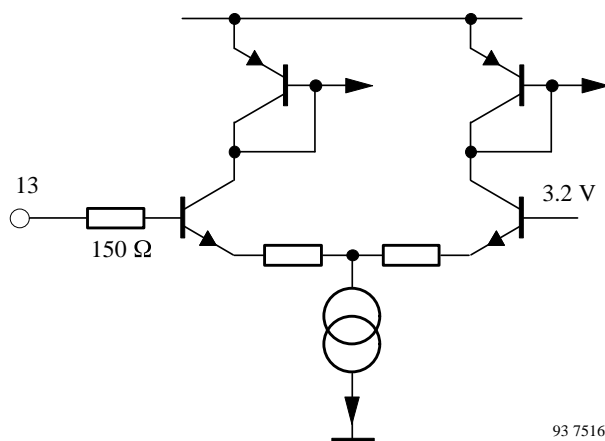

Figure 10. Pin 13: Volume control

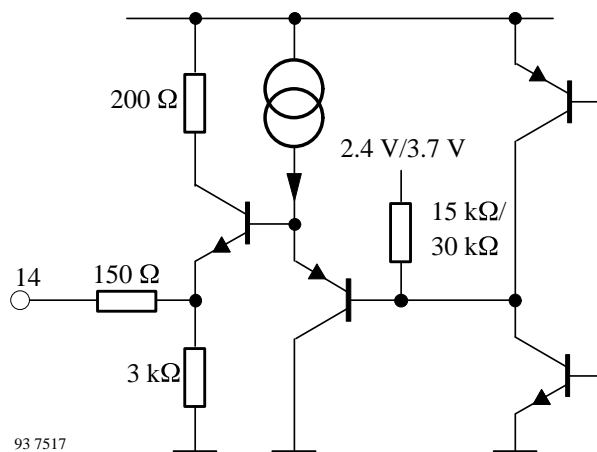

Figure 11. Pin 14: AF output (controlled)

Internal Pin Circuit Diagrams (continued)

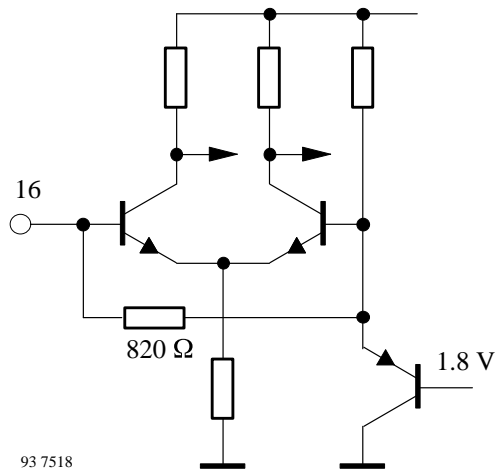
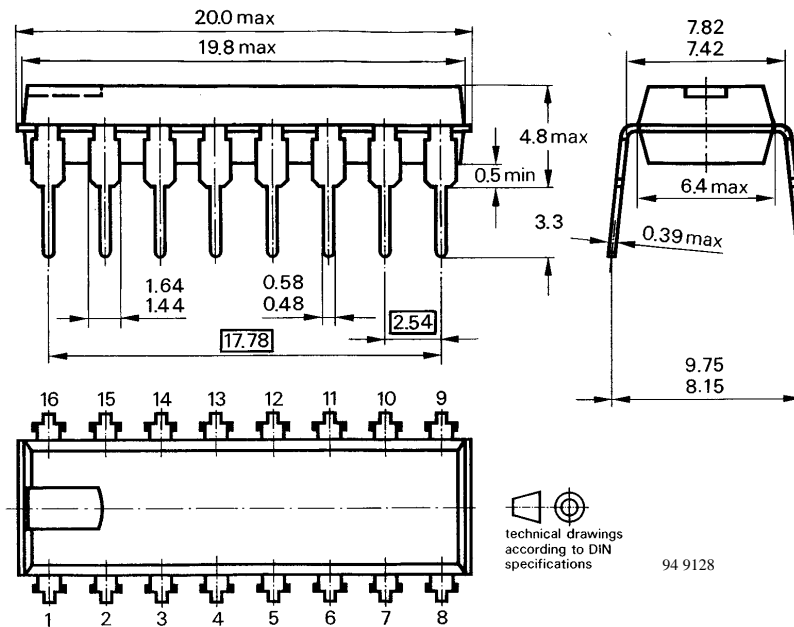

Figure 12. Pin 16: IF input

Dimensions in mm

Package: DIP16



Ozone Depleting Substances Policy Statement

It is the policy of **TEMIC TELEFUNKEN microelectronic GmbH** to

1. Meet all present and future national and international statutory requirements.
2. Regularly and continuously improve the performance of our products, processes, distribution and operating systems with respect to their impact on the health and safety of our employees and the public, as well as their impact on the environment.

It is particular concern to control or eliminate releases of those substances into the atmosphere which are known as ozone depleting substances (ODSs).

The Montreal Protocol (1987) and its London Amendments (1990) intend to severely restrict the use of ODSs and forbid their use within the next ten years. Various national and international initiatives are pressing for an earlier ban on these substances.

TEMIC TELEFUNKEN microelectronic GmbH semiconductor division has been able to use its policy of continuous improvements to eliminate the use of ODSs listed in the following documents.

1. Annex A, B and list of transitional substances of the Montreal Protocol and the London Amendments respectively
2. Class I and II ozone depleting substances in the Clean Air Act Amendments of 1990 by the Environmental Protection Agency (EPA) in the USA
3. Council Decision 88/540/EEC and 91/690/EEC Annex A, B and C (transitional substances) respectively.

TEMIC can certify that our semiconductors are not manufactured with ozone depleting substances and do not contain such substances.

We reserve the right to make changes to improve technical design and may do so without further notice.

Parameters can vary in different applications. All operating parameters must be validated for each customer application by the customer. Should the buyer use TEMIC products for any unintended or unauthorized application, the buyer shall indemnify TEMIC against all claims, costs, damages, and expenses, arising out of, directly or indirectly, any claim of personal damage, injury or death associated with such unintended or unauthorized use.

TEMIC TELEFUNKEN microelectronic GmbH, P.O.B. 3535, D-74025 Heilbronn, Germany
Telephone: 49 (0)7131 67 2831, Fax number: 49 (0)7131 67 2423