

# Off-Line Battery Charger Circuit

## FEATURES

- Transformerless Off-Line Operation
- Low Voltage Operation to 0.8V
- Ideal for Battery Trickle Charger Applications
- Current Mode Operation With 100mV Shunt
- Voltage Mode Operation With Fixed 1.25V Output or Resistor Adjustable Output
- Efficient BiCMOS Design
- Inherent Short Circuit Protection

## DESCRIPTION

The UCC3890 controller is optimized for use as an off-line, low power, low voltage, regulated current supply, ideally suited for battery trickle charger applications. The unique circuit topology used in this device can be visualized as two cascaded flyback converters; each operating in the discontinuous mode, and both driven from a single external power switch. The significant benefit of this approach is the ability to charge low voltage batteries in off-line applications with no transformer, and low internal losses.

The control algorithm used by the UCC3890 forces a switch on time inversely proportional to the input line voltage, while the switch off time is inversely proportional to the output voltage. This action is automatically controlled by an internal feedback loop and reference. The cascaded configuration allows a large voltage conversion ratio with reasonable switch duty cycle.

While the UCC3890 is ideally suited for control of constant current battery chargers, provision is also made to operate as a fixed 1.25V regulated supply, or to use a resistor voltage divider to obtain output voltages higher than 1.25V.

## BLOCK DIAGRAM

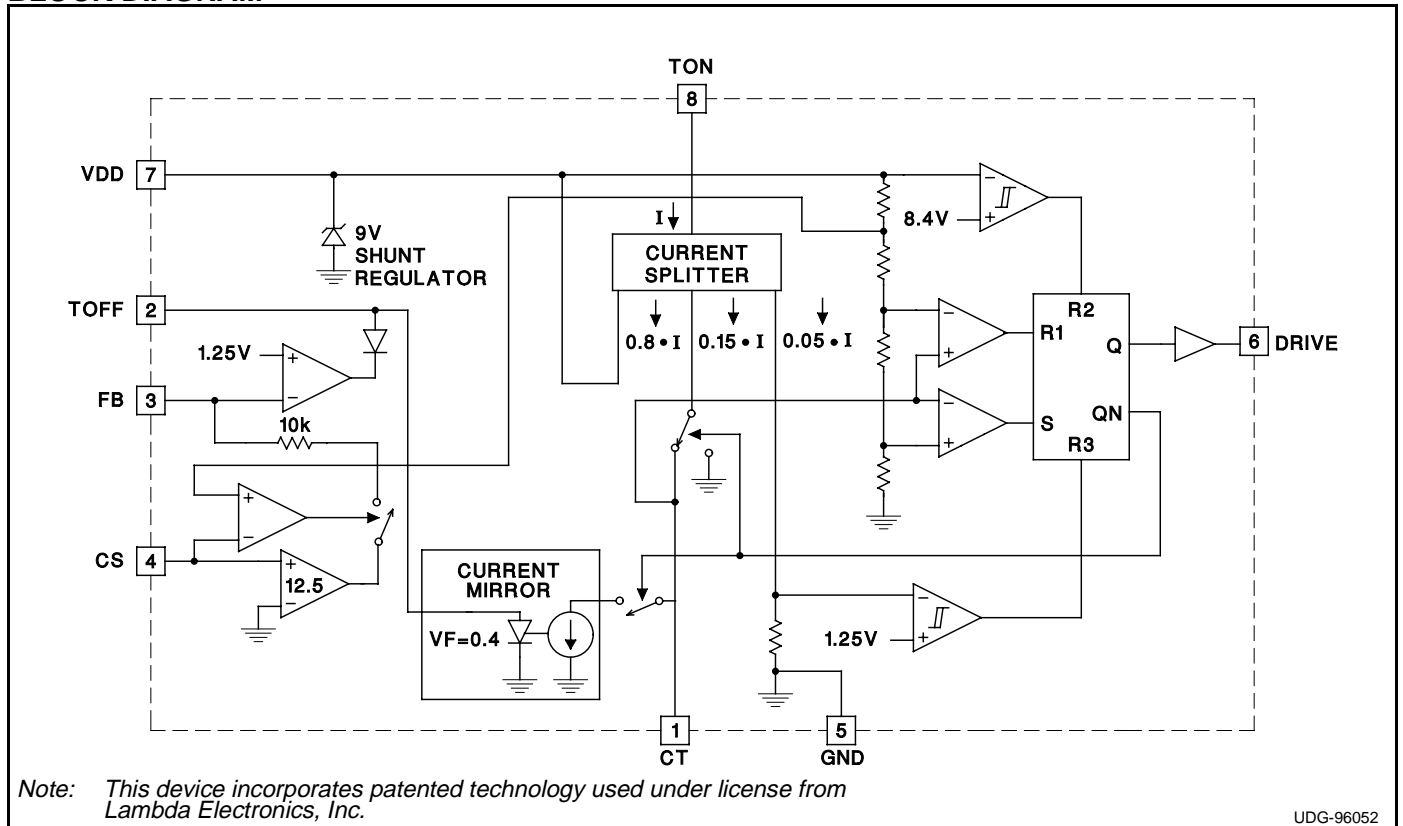

## ABSOLUTE MAXIMUM RATINGS

I <sub>DD</sub> .....	7.5mA
Current into TON .....	7.5mA
Voltage on V <sub>OUT</sub> .....	20V
Current into TOFF .....	250μA
Storage Temperature .....	-65°C to +150°C
Junction Temperature .....	-55°C to +150°C
Lead Temperature (Soldering, 10 sec.) .....	+300°C

Currents are positive into, negative out of the specified terminal.  
Consult Packaging Section of Databook for thermal limitations and considerations of packages.

## CONNECTION DIAGRAMS

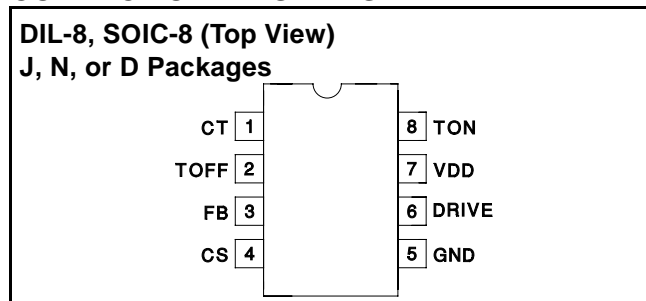

**ELECTRICAL CHARACTERISTICS:** Unless otherwise stated, these specifications apply for T<sub>A</sub> = -55°C to 125°C for UCC1890, -40°C to 85°C for the UCC2890, and 0°C to 70°C for the UCC3890. No load at DRIVE pin (C<sub>LOAD</sub> = 0), T<sub>A</sub> = T<sub>J</sub>.

PARAMETER	TEST CONDITIONS	MIN	TYP	MAX	UNITS
<b>General</b>					
VDD Zener Voltage	I <sub>DD</sub> = 4.75mA, I <sub>TON</sub> = 0mA	8.3	9.0	9.4	V
Minimum Operating Current I <sub>TON</sub>	I <sub>DD</sub> = -1mA, F = 150kHz		1.65	2.0	mA
<b>Undervoltage Lockout</b>					
Minimum Voltage to Start	FB = 0	7.8	8.6	9.2	V
Minimum Voltage after Start	FB = 0	5.75	6.3	6.65	V
Hysteresis	FB = 0	1.8	2.3	2.6	V
VDD - V <sub>START</sub>	FB = 0	0.2	0.4	0.7	V
<b>Oscillator</b>					
Amplitude	I <sub>TON</sub> = 3mA; I <sub>TOFF</sub> = 50μA; V <sub>FB</sub> = 0V CT = 100pF	3.1	3.4	3.7	V
CT to DRIVE High Delay	Overdrive = 200mV		80	200	ns
CT to DRIVE Low Delay	Overdrive = 200mV		50	100	ns
Charge Coefficient I <sub>CT</sub> /I <sub>TON</sub>	I <sub>TON</sub> = 3mA; V <sub>CT</sub> = 3.0V	0.135	0.15	0.165	μA/μA
Discharge Coefficient I <sub>CT</sub> /I <sub>TOFF</sub>	I <sub>TOFF</sub> = 50μA; V <sub>CT</sub> = 3.0V	0.95	1.00	1.05	μA/μA
<b>Driver</b>					
V <sub>OL</sub>	I = 100mA (Note 1)		0.7	1.8	V
V <sub>OH</sub>	I = -100mA referred to VDD (Note 1)	-2.9	-1.5		V
Rise Time	C <sub>L</sub> = 1nF		35	70	ns
Fall Time	C <sub>L</sub> = 1nF		30	60	ns
<b>Line Voltage Detection</b>					
Minimum I <sub>TON</sub> for Fault		1.0	1.5	2.0	mA
I <sub>TON</sub> Detector Hysteresis			110		μA
On Time During Fault			0.5		μs
<b>V<sub>out</sub> Error Amplifier</b>					
Reference Level	I <sub>TOFF</sub> = 50μA, I <sub>CT</sub> = 25μA, T <sub>J</sub> = 25°C	1.20	1.25	1.30	V
	I <sub>TOFF</sub> = 50μA, I <sub>CT</sub> = 25μA, Over Temperature	1.15	1.25	1.35	V
Voltage at TOFF	I <sub>TOFF</sub> = 50μA	0.3	0.4	0.5	V
Regulation gm	I <sub>TOFF</sub> = 50μA (Note 2)	2.0	4.0	7.7	mA/V
<b>Current Sense Amplifier</b>					
Gain	V <sub>CS</sub> = 90 - 110mV	11.8	12.5	13.0	V/V
Input Offset Voltage	V <sub>CS</sub> = 90 - 110mV	-5	0	5	mV
Input Voltage for CS Amplifier Enabled	I <sub>TON</sub> = 3mA, Referred to VDD	-1.5	-0.8		V
Input Voltage for CS Amplifier Disabled	I <sub>TON</sub> = 3mA, Referred to VDD		-0.8	-0.3	V

Note 1: VDD forced to 100mV below VDD Zener Voltage

Note 2: gm is defined as  $\frac{\Delta I_{CT}}{\Delta V_{FB}}$  for the values of V<sub>FB</sub> where the error amp is in regulation. The two points used to calculate gm are for I<sub>CT</sub> at 65% and 35% of its maximum value.

## PIN DESCRIPTIONS

**CS:** The high side of the current sense shunt is connected to this pin. Short CS to VDD for voltage feedback operation.

**CT:** Oscillator timing capacitor is connected to this pin.

**DRIVE:** Gate drive to external power switch.

**FB:** Output of current sense amplifier. This pin can be used for direct output voltage feedback if the current sense amp input pin CS is shorted to the VDD pin.

**GND:** Ground pin.

**TOFF:** Resistor R<sub>OFF</sub> connects from voltage output to this pin to provide a maximum capacitor discharge current proportional to output voltage.

**TON:** Resistor R<sub>ON</sub> connects from line input to this pin to provide capacitor charge current proportional to line voltage. The current in R<sub>ON</sub> also provides power for the 9V shunt regulator at VDD.

**VDD:** Output of 9V shunt regulator.

## APPLICATION INFORMATION

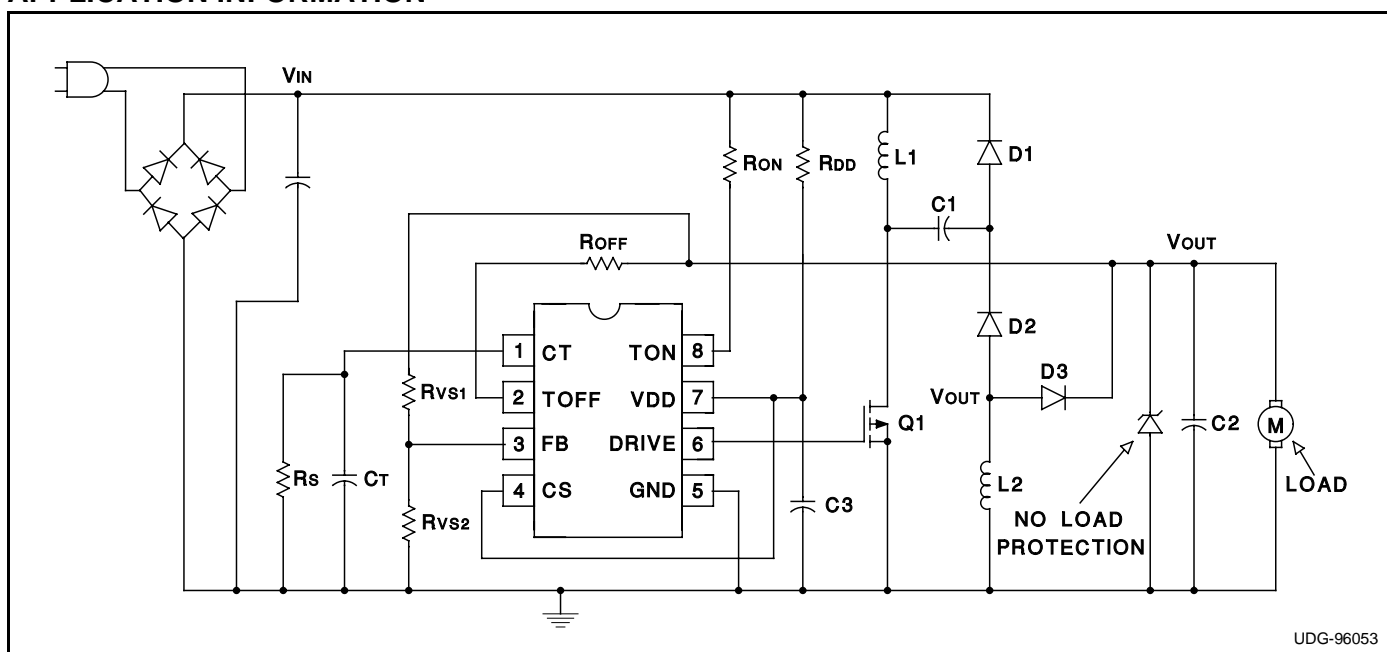

Figure 1. Typical Voltage Mode Application

## OPERATION (VOLTAGE OUTPUT)

Figure 1 shows a typical voltage mode application. When input voltage is first applied, all of the current through R<sub>DD</sub> and 80% of the current through R<sub>ON</sub>, charge the external capacitor C<sub>3</sub> connected to VDD. As the voltage builds on VDD, undervoltage lockout holds the circuit off and the output DRIVE low until VDD reaches 8.4V. At this time, DRIVE goes high, turning on the external power switch Q1, and 15% of the current into TON is directed to the timing capacitor C<sub>T</sub>. The voltage at TON is fixed at approximately 11V, so C<sub>T</sub> charges to a fixed threshold with current

$$I = 0.2 \cdot \frac{V_{IN} - 11V}{R_{ON}}$$

Since the input line is much greater than 11V, the charge current is approximately proportional to the input line voltage. DRIVE is only high while C<sub>T</sub> is charging, so

the power switch on time is inversely proportional to line voltage. This provides a constant line voltage-switch on time product.

At the end of the switch on time, Q1 is turned off, and the 15% of the R<sub>ON</sub> current which was charging C<sub>T</sub> is diverted to ground. The power switch off time is controlled by discharge of C<sub>T</sub>, which is determined by the output voltage as described here:

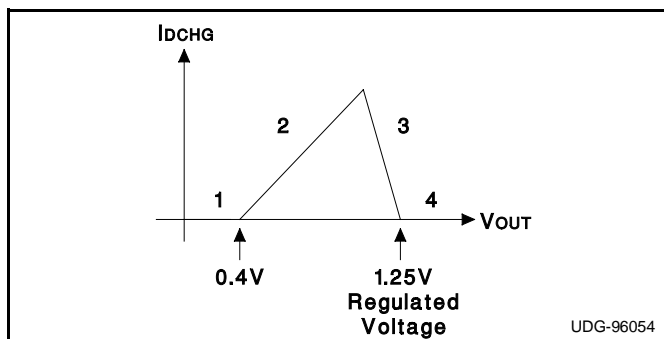

**APPLICATION INFORMATION (cont.)**

1. When  $V_{OUT} = 0$ , the off time is infinite. This feature provides inherent short circuit protection. However, to ensure output voltage startup when the output is not a short, a high value resistor,  $R_S$ , is placed in parallel with  $C_T$  to establish a minimum switching frequency.
2. As  $V_{OUT}$  rises above approximately 0.4V,  $I_{DCHG}$  is set by  $R_{OFF}$ , and is defined by

$$I_{DCHG} = \frac{V_{OUT} - 0.4V}{R_{OFF}}$$

As  $V_{OUT}$  increases,  $I_{DCHG}$  increases resulting in the reduction of off time. The frequency of operation increases and  $V_{OUT}$  rises quickly to its regulated value.

3. In this region, a transconductance amplifier reduces  $I_{DCHG}$  in order to maintain  $V_{OUT}$  in regulation. The input to the transconductance amplifier is the pin FB. (In this mode the pin CS should be shorted to  $V_{DD}$ .) FB can either be connected directly to  $V_{OUT}$  to regulate at nominal  $V_{OUT} = 1.25V$  or to be connected to  $V_{OUT}$  through a resistor divider  $R_{VS1}/R_{VS2}$  to regulate at nominal

$$V_{OUT} = \frac{1.25V \cdot (R_{VS1} + R_{VS2})}{R_{VS2}}$$

4. If  $V_{OUT}$  should rise above its regulation range,  $I_{DCHG}$  falls to zero and the circuit returns to the minimum frequency established by  $R_S$  and  $C_T$ .

The range of switching frequencies is established by  $R_{ON}$ ,  $R_{OFF}$ ,  $R_S$ , and  $C_T$  as follows:

$$\text{Frequency} = \frac{1}{T_{ON} + T_{OFF}}$$

$$T_{ON} = \frac{C_T \cdot 3.4V \cdot 0.15 \cdot R_{ON}}{V_{IN} - 11V}$$

$$T_{OFF(MAX)} = 1.5 \cdot R_S \cdot C_T \text{ (regions 1 and 4)}$$

$$T_{OFF} = \frac{C_T \cdot 3.4V \cdot R_{OFF}}{V_{OUT} - 0.4V} \text{ (region 2)}$$

The above equations assume  $V_{DD} = 9$ , the voltage at  $T_{ON} = 11V$ , the voltage at  $T_{OFF} = 0.4V$ .

**OPERATION (CURRENT OUTPUT)**

Figure 2 shows a typical current mode application. In current mode, operation is the same as in voltage mode, except that in region 3 the transconductance amplifier is controlled by the current sense amplifier which senses the voltage across a shunt resistor  $R_{SH}$ . The circuit then regulates the current in the shunt to the nominal value

$$I_{SH} = \frac{100mV}{R_{SH}}$$

The circuit shown in this schematic would be suitable for an application which trickle charges a battery at a low current, (e.g.  $C/10$ ), and has a battery load which draws a high current, (e.g.  $C$ ), when turned on. In that case,  $R_{SH1}$  value is chosen so that

$$\frac{100mV}{R_{SH1}} = \frac{C}{10}$$

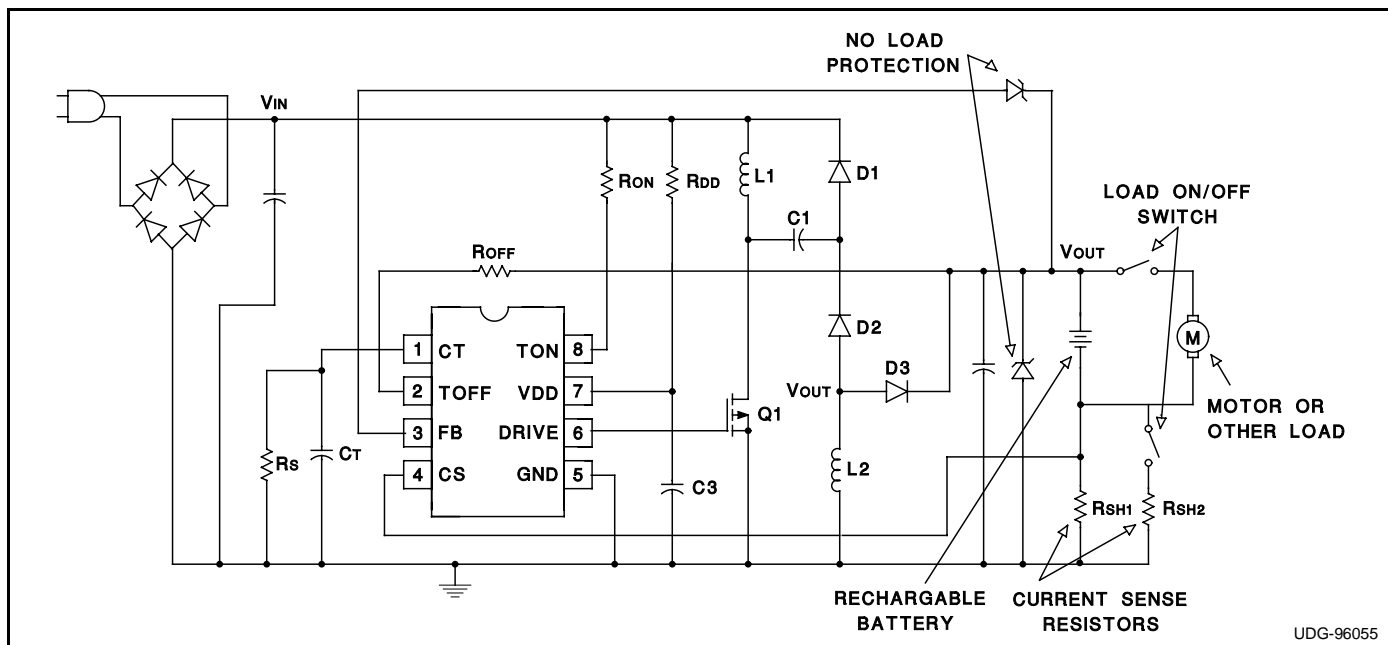

Figure 2. Typical Current Mode Application

### APPLICATION INFORMATION (cont.)

If  $R_{SH2}$  is chosen so that

$$\frac{100\text{mV}}{R_{SH2}} = C$$

then the regulator output will assist the battery, minimizing or eliminating battery output current.

### DESIGN EXAMPLE

A typical design has the following requirements:

$V_{IN}$	=	80 to 132 VAC or 100 to 180 VDC
$V_{OUT}$	=	1.25V
$V_{OUT}'$	=	2.0V (assumes 1.25 V $V_{OUT}$ with 750mV forward drop in D3)
$I_{LOAD}$	=	500mADC max
$F_{SWITCHING}$	=	100kHz
$\eta$ (eff.)	=	50% (excluding efficiency losses in D3 which will be very large due to the low output voltage. Losses in D3 are accounted for by using $V_{OUT}'$ in the calculations).

Component values are indicated in Figure 3. The explanation for the choices in component values follows.

First calculate the maximum duty cycle,  $d(\text{max})$ . To calculate this assume that at maximum load/minimum line conditions, the converter will be at the continuous conduction boundary and there will be no idle time after the inductors are discharged. For all other load/line conditions, the UCC3890 will stretch the off time, to create an idle time after the inductors are discharged, in order to

maintain a constant output voltage. For a single flyback stage at continuous conduction boundary

$$d = \frac{1}{1 + \frac{V_{IN}}{V_{OUT}}}$$

For the cascaded flyback stages of the UCC3890 topology, the corresponding equation is

$$d(\text{max}) = \frac{1}{1 + \sqrt{\frac{V_{IN}}{V_{OUT}'}}}$$

in this case

$$d(\text{max}) = \frac{1}{1 + \sqrt{\frac{100\text{V}}{2\text{V}}}} = 0.125$$

Next using the operating frequency and the maximum duty cycle to calculate the maximum on time

$$T_{ON}(\text{max}) = \frac{d(\text{max})}{F_{SWITCHING}}$$

in this case

$$T_{ON}(\text{max}) = \frac{0.125}{100\text{kHz}} = 1.25\mu\text{s}$$

correspondingly

$$T_{OFF}(\text{min}) = \frac{1 - 0.125}{100\text{kHz}} = 8.75\mu\text{s}$$

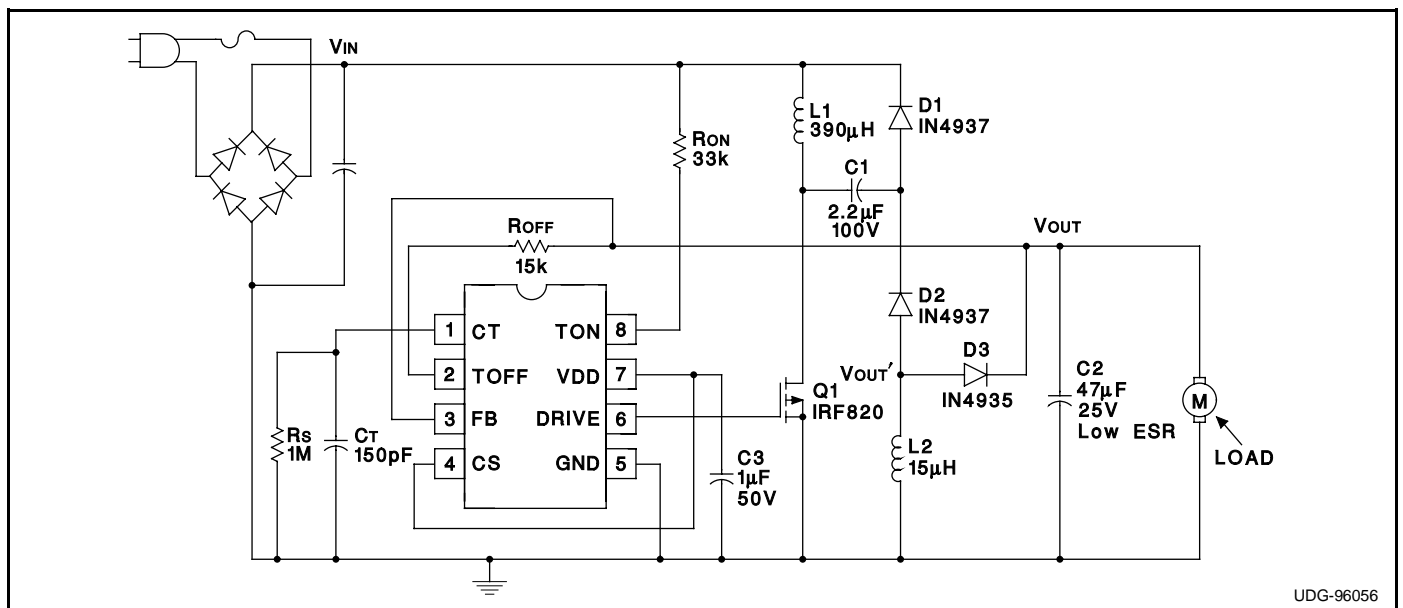

Figure 3. Example Application

### APPLICATION INFORMATION (cont.)

The average input current at minimum line and maximum load will be

$$I_{IN} = \frac{I_{OUT}}{\eta} \cdot \frac{V_{OUT'}}{V_{IN}}$$

in this case

$$I_{IN} = \frac{500\text{mA}}{0.5} \cdot \frac{2\text{V}}{100\text{V}} = 20\text{mA}$$

Knowing that input current is drawn from the line only during TON, calculate the peak current in L1 to be

$$I_{L1}(\text{pk}) = 2 \cdot I_{IN} \cdot \frac{TON + TOFF}{TON}$$

in this case

$$I_{L1}(\text{pk}) = 2 \cdot 20\text{mA} \cdot \frac{1.25\mu\text{s} + 8.75\mu\text{s}}{1.25\mu\text{s}} = 320\text{mA}$$

Now calculate the value for L1

$$L1 = V_{IN} \cdot \frac{TON}{I_{L1}(\text{pk})}$$

in this case

$$L1 = 100\text{V} \cdot \frac{1.25\mu\text{s}}{320\text{mA}} = 390\mu\text{H}$$

The output voltage of the first flyback stage is

$$V_{C1} = V_{IN} \cdot \frac{TON}{TOFF}$$

in this case

$$V_{C1} = 100\text{V} \cdot \frac{1.25\mu\text{s}}{8.75\mu\text{s}} = 14.3\text{V}$$

Knowing that output current is provided to the load only during TOFF, calculate the peak current in L2 to be

$$I_{L2}(\text{pk}) = 2 \cdot I_{OUT} \cdot \frac{TON + TOFF}{TOFF}$$

in this case

$$I_{L2}(\text{pk}) = 2 \cdot 0.5\text{A} \cdot \frac{1.25\mu\text{s} + 8.75\mu\text{s}}{8.75\mu\text{s}} = 1.14\text{A}$$

Now calculate the value of L2

$$L2 = V_{OUT'} \cdot \frac{TOFF}{I_{L2}(\text{pk})}$$

in this case

$$L2 = 2\text{V} \cdot \frac{8.75\mu\text{s}}{1.14\text{A}} = 15\mu\text{H}$$

For all of the calculations so far only the maximum load/minimum line condition have been considered. The

entire range of operation must be considered to choose values for the rest of the components.

Under all normal operating conditions the current  $I_{TON}$ , (which is the current in  $R_{ON}$ ), should be greater than 2mA and less than 7.5mA. In this case set  $R_{ON}$  to give  $I_{TON} = 2.8\text{mA}$  at low line. The voltage at TON will be about 11V so

$$R_{ON} = \frac{100\text{V} - 11\text{V}}{2.8\text{mA}} = 33\text{k}\Omega$$

With  $R_{ON} = 33\text{k}$ ,  $I_{TON}$  at high line will be

$$I_{TON} = \frac{180\text{V} - 11\text{V}}{33\text{k}} = 5.1\text{mA}$$

At high line, the power dissipation in  $R_{ON}$  will be

$$P(R_{ON}) = (180\text{V} - 11\text{V}) \cdot 5.1\text{mA} = 860\text{mW}$$

$R_{ON}$  will need to be at least a 1W resistor. Alternately it could be four 1/4W 8.2k $\Omega$  resistors in series.

Once  $R_{ON}$  is set,  $C_T$  can be chosen. The charge current for  $C_T$  is nominally 15% of  $I_{TON}$ , and the nominal oscillator amplitude is 3.4V, so

$$TON = \frac{C_T \cdot 3.4\text{V}}{0.15 \cdot I_{TON}}$$

solving for  $C_T$

$$C_T = \frac{TON \cdot 0.15 \cdot I_{TON}}{3.4\text{V}}$$

$I_{TON}$  at low line is 2.8mA, and the target TON at low line is 1.25 $\mu\text{s}$ , so in this case

$$C_T = \frac{1.25\mu\text{s} \cdot 0.15 \cdot 2.8\text{mA}}{3.4\text{V}} = 150\text{pF}$$

The final component to be chosen is  $R_{OFF}$ , which determines the minimum value of TOFF. When the output voltage is below the regulation point, the discharge current for  $C_T$  is equal to  $I_{TOFF}$  (the current in  $R_{OFF}$ ). Under that condition

$$TOFF = \frac{C_T \cdot 3.4\text{V}}{I_{TOFF}}$$

since the voltage at the TOFF pin = 0.4V

$$I_{TOFF} = \frac{V_{OUT} - 0.4\text{V}}{R_{OFF}}$$

substituting and solving for  $R_{OFF}$

$$R_{OFF} = \frac{TOFF \cdot (V_{OUT} - 0.4\text{V})}{C_T \cdot 3.4\text{V}}$$

The largest discharge current, and hence the minimum off time, will occur when the output is about 10mV be-

**APPLICATION INFORMATION (cont.)**

low the regulation point of 1.25V. The minimum value for TOFF is 8.75µs. So in this case

$$R_{OFF} = \frac{8.75\mu s \cdot (1.24V - 0.4V)}{150pF \cdot 3.4V} = 15k$$

**OTHER APPLICATION CONSIDERATIONS**

**Output Capacitor:** For best regulation of the output voltage or current, the output capacitor should be a low ESR type. This is especially true when operating in current sense mode with a non-linear load such as a battery. If a low ESR capacitor cannot be used, excellent regulation can also be achieved by placing a low pass R/C filter between the current shunt and the CS input.

**No Load Operation:** The UCC3890 is inherently protected for short circuits, but not for open circuits. If the load is removed, the output voltage will quickly rise up to the regulation point. Once the output is above the regulation voltage, the oscillator will drop to the minimum frequency set by RS/CT. With no load on the output, even at this low frequency the output voltage can quickly rise to a dangerous level. To protect against this, it is recommended that a zener or other voltage clamp always be connected across the output. The clamp should be chosen to be above the normal range of output voltage, but low enough to protect the output capacitor. In current sense operation, removal of the load will also break the regulation loop, in which case a sim-

ple clamp on the output may not be adequate. In current sense mode it is recommended that a second zener be connected from the output to the FB pin, the breakdown voltage of this clamp chosen to be high enough so that it will not conduct during normal operation, but will conduct at least 2V lower than the breakdown voltage of the other clamp.

**Gate Drive for the External FET:** The UCC3890 is guaranteed to be able to deliver at least 1mA of steady state current to the gate of the external FET at ITON = 2mA. If ITON is higher than 2mA, 80% of the additional current is available to drive the FET gate. If, as in the design example above, a moderate sized FET such as the IRF820 is used, the operating frequency is 100kHz, and the minimum ITON at low line is 2.8mA, then the available gate drive current may be adequate. The IRF820 needs about 13nC to charge the gate on each cycle. At 100kHz, this is equivalent to 1.3mA steady state; below the minimum 1.64mA available. In some combinations of a larger FET, and/or higher frequency operation, the current available for driving the gate may not be adequate. In that case extra current may be provided by connecting a resistor RDD from the line input to the VDD pin. This resistor should be sized so that under all conditions the current input to VDD is below the 7.5mA absolute maximum limit. RDD will likely need to be a power resistor.

**PACKAGING INFORMATION**

Orderable Device	Status <sup>(1)</sup>	Package Type	Package Drawing	Pins	Package Qty	Eco Plan <sup>(2)</sup>	Lead/Ball Finish	MSL Peak Temp <sup>(3)</sup>
UCC3890D	OBSOLETE	SOIC	D	8		TBD	Call TI	Call TI
UCC3890DTR	OBSOLETE	SOIC	D	8		TBD	Call TI	Call TI
UCC3890N	OBSOLETE	PDIP	P	8		TBD	Call TI	Call TI

<sup>(1)</sup> The marketing status values are defined as follows:

**ACTIVE:** Product device recommended for new designs.

**LIFEBUY:** TI has announced that the device will be discontinued, and a lifetime-buy period is in effect.

**NRND:** Not recommended for new designs. Device is in production to support existing customers, but TI does not recommend using this part in a new design.

**PREVIEW:** Device has been announced but is not in production. Samples may or may not be available.

**OBSOLETE:** TI has discontinued the production of the device.

<sup>(2)</sup> Eco Plan - The planned eco-friendly classification: Pb-Free (RoHS), Pb-Free (RoHS Exempt), or Green (RoHS & no Sb/Br) - please check <http://www.ti.com/productcontent> for the latest availability information and additional product content details.

**TBD:** The Pb-Free/Green conversion plan has not been defined.

**Pb-Free (RoHS):** TI's terms "Lead-Free" or "Pb-Free" mean semiconductor products that are compatible with the current RoHS requirements for all 6 substances, including the requirement that lead not exceed 0.1% by weight in homogeneous materials. Where designed to be soldered at high temperatures, TI Pb-Free products are suitable for use in specified lead-free processes.

**Pb-Free (RoHS Exempt):** This component has a RoHS exemption for either 1) lead-based flip-chip solder bumps used between the die and package, or 2) lead-based die adhesive used between the die and leadframe. The component is otherwise considered Pb-Free (RoHS compatible) as defined above.

**Green (RoHS & no Sb/Br):** TI defines "Green" to mean Pb-Free (RoHS compatible), and free of Bromine (Br) and Antimony (Sb) based flame retardants (Br or Sb do not exceed 0.1% by weight in homogeneous material)

<sup>(3)</sup> MSL, Peak Temp. -- The Moisture Sensitivity Level rating according to the JEDEC industry standard classifications, and peak solder temperature.

**Important Information and Disclaimer:**The information provided on this page represents TI's knowledge and belief as of the date that it is provided. TI bases its knowledge and belief on information provided by third parties, and makes no representation or warranty as to the accuracy of such information. Efforts are underway to better integrate information from third parties. TI has taken and continues to take reasonable steps to provide representative and accurate information but may not have conducted destructive testing or chemical analysis on incoming materials and chemicals. TI and TI suppliers consider certain information to be proprietary, and thus CAS numbers and other limited information may not be available for release.

In no event shall TI's liability arising out of such information exceed the total purchase price of the TI part(s) at issue in this document sold by TI to Customer on an annual basis.



## IMPORTANT NOTICE

Texas Instruments Incorporated and its subsidiaries (TI) reserve the right to make corrections, modifications, enhancements, improvements, and other changes to its products and services at any time and to discontinue any product or service without notice. Customers should obtain the latest relevant information before placing orders and should verify that such information is current and complete. All products are sold subject to TI's terms and conditions of sale supplied at the time of order acknowledgment.

TI warrants performance of its hardware products to the specifications applicable at the time of sale in accordance with TI's standard warranty. Testing and other quality control techniques are used to the extent TI deems necessary to support this warranty. Except where mandated by government requirements, testing of all parameters of each product is not necessarily performed.

TI assumes no liability for applications assistance or customer product design. Customers are responsible for their products and applications using TI components. To minimize the risks associated with customer products and applications, customers should provide adequate design and operating safeguards.

TI does not warrant or represent that any license, either express or implied, is granted under any TI patent right, copyright, mask work right, or other TI intellectual property right relating to any combination, machine, or process in which TI products or services are used. Information published by TI regarding third-party products or services does not constitute a license from TI to use such products or services or a warranty or endorsement thereof. Use of such information may require a license from a third party under the patents or other intellectual property of the third party, or a license from TI under the patents or other intellectual property of TI.

Reproduction of TI information in TI data books or data sheets is permissible only if reproduction is without alteration and is accompanied by all associated warranties, conditions, limitations, and notices. Reproduction of this information with alteration is an unfair and deceptive business practice. TI is not responsible or liable for such altered documentation. Information of third parties may be subject to additional restrictions.

Resale of TI products or services with statements different from or beyond the parameters stated by TI for that product or service voids all express and any implied warranties for the associated TI product or service and is an unfair and deceptive business practice. TI is not responsible or liable for any such statements.

TI products are not authorized for use in safety-critical applications (such as life support) where a failure of the TI product would reasonably be expected to cause severe personal injury or death, unless officers of the parties have executed an agreement specifically governing such use. Buyers represent that they have all necessary expertise in the safety and regulatory ramifications of their applications, and acknowledge and agree that they are solely responsible for all legal, regulatory and safety-related requirements concerning their products and any use of TI products in such safety-critical applications, notwithstanding any applications-related information or support that may be provided by TI. Further, Buyers must fully indemnify TI and its representatives against any damages arising out of the use of TI products in such safety-critical applications.

TI products are neither designed nor intended for use in military/aerospace applications or environments unless the TI products are specifically designated by TI as military-grade or "enhanced plastic." Only products designated by TI as military-grade meet military specifications. Buyers acknowledge and agree that any such use of TI products which TI has not designated as military-grade is solely at the Buyer's risk, and that they are solely responsible for compliance with all legal and regulatory requirements in connection with such use.

TI products are neither designed nor intended for use in automotive applications or environments unless the specific TI products are designated by TI as compliant with ISO/TS 16949 requirements. Buyers acknowledge and agree that, if they use any non-designated products in automotive applications, TI will not be responsible for any failure to meet such requirements.

Following are URLs where you can obtain information on other Texas Instruments products and application solutions:

### Products

Amplifiers	<a href="http://amplifier.ti.com">amplifier.ti.com</a>
Data Converters	<a href="http://dataconverter.ti.com">dataconverter.ti.com</a>
DSP	<a href="http://dsp.ti.com">dsp.ti.com</a>
Clocks and Timers	<a href="http://www.ti.com/clocks">www.ti.com/clocks</a>
Interface	<a href="http://interface.ti.com">interface.ti.com</a>
Logic	<a href="http://logic.ti.com">logic.ti.com</a>
Power Mgmt	<a href="http://power.ti.com">power.ti.com</a>
Microcontrollers	<a href="http://microcontroller.ti.com">microcontroller.ti.com</a>
RFID	<a href="http://www.ti-rfid.com">www.ti-rfid.com</a>
RF/IF and ZigBee® Solutions	<a href="http://www.ti.com/lprf">www.ti.com/lprf</a>

### Applications

Audio	<a href="http://www.ti.com/audio">www.ti.com/audio</a>
Automotive	<a href="http://www.ti.com/automotive">www.ti.com/automotive</a>
Broadband	<a href="http://www.ti.com/broadband">www.ti.com/broadband</a>
Digital Control	<a href="http://www.ti.com/digitalcontrol">www.ti.com/digitalcontrol</a>
Medical	<a href="http://www.ti.com/medical">www.ti.com/medical</a>
Military	<a href="http://www.ti.com/military">www.ti.com/military</a>
Optical Networking	<a href="http://www.ti.com/opticalnetwork">www.ti.com/opticalnetwork</a>
Security	<a href="http://www.ti.com/security">www.ti.com/security</a>
Telephony	<a href="http://www.ti.com/telephony">www.ti.com/telephony</a>
Video & Imaging	<a href="http://www.ti.com/video">www.ti.com/video</a>
Wireless	<a href="http://www.ti.com/wireless">www.ti.com/wireless</a>

Mailing Address: Texas Instruments, Post Office Box 655303, Dallas, Texas 75265  
Copyright © 2008, Texas Instruments Incorporated