

Dual N-Channel 2.5-V (G-S) MOSFET

2.5-V Rated

PRODUCT SUMMARY		
V_{DS} (V)	$r_{DS(on)}$ (Ω)	I_D (A)
20	0.05 @ $V_{GS} = 4.5$ V	± 5.0
	0.06 @ $V_{GS} = 3.0$ V	± 4.2
	0.08 @ $V_{GS} = 2.5$ V	± 3.6

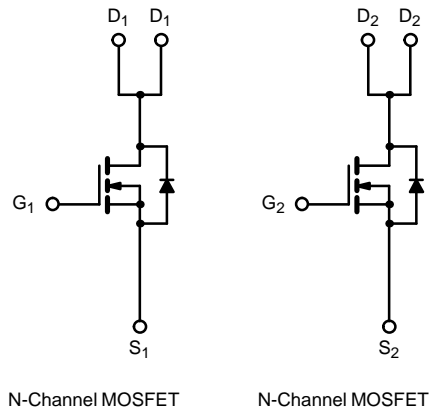
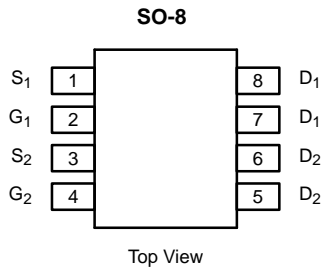

ABSOLUTE MAXIMUM RATINGS ($T_A = 25^\circ\text{C}$ UNLESS OTHERWISE NOTED)			
Parameter	Symbol	Limit	Unit
Drain-Source Voltage	V_{DS}	20	V
Gate-Source Voltage	V_{GS}	± 12	
Continuous Drain Current ($T_J = 150^\circ\text{C}$) ^a	I_D	$T_A = 25^\circ\text{C}$	± 5.0
		$T_A = 70^\circ\text{C}$	± 4.0
Pulsed Drain Current	I_{DM}	± 48	A
Continuous Source Current (Diode Conduction) ^a	I_S	1.7	
Maximum Power Dissipation ^a	P_D	$T_A = 25^\circ\text{C}$	2
		$T_A = 70^\circ\text{C}$	1.3
Operating Junction and Storage Temperature Range	T_J, T_{stg}	-55 to 150	$^\circ\text{C}$

THERMAL RESISTANCE RATINGS			
Parameter	Symbol	Limit	Unit
Maximum Junction-to-Ambient ^a	R_{thJA}	62.5	$^\circ\text{C/W}$

Notes

a. Surface Mounted on FR4 Board, $t \leq 10$ sec.

For SPICE model information via the Worldwide Web: <http://www.vishay.com/www/product/spice.htm>



Specifications ($T_J = 25^\circ\text{C}$ Unless Otherwise Noted)						
Parameter	Symbol	Test Condition	Min	Typ ^a	Max	Unit
Static						
Gate Threshold Voltage	$V_{GS(th)}$	$V_{DS} = V_{GS}, I_D = 250 \mu\text{A}$	0.8			V
Gate-Body Leakage	I_{GSS}	$V_{DS} = 0 \text{ V}, V_{GS} = \pm 12 \text{ V}$			± 100	nA
Zero Gate Voltage Drain Current	I_{DSS}	$V_{DS} = 10 \text{ V}, V_{GS} = 0 \text{ V}$			1	μA
		$V_{DS} = 16 \text{ V}, V_{GS} = 0 \text{ V}, T_J = 70^\circ\text{C}$			5	
On-State Drain Current ^b	$I_{D(on)}$	$V_{DS} \geq 5 \text{ V}, V_{GS} = 5 \text{ V}$	30			A
Drain-Source On-State Resistance ^b	$r_{DS(on)}$	$V_{GS} = 7.2 \text{ V}, I_D = 5.0 \text{ A}$	0.025	0.038	0.045	Ω
		$V_{GS} = 4.5 \text{ V}, I_D = 5.0 \text{ A}$		0.041	0.05	
		$V_{GS} = 3.0 \text{ V}, I_D = 3.9 \text{ A}$		0.050	0.06	
		$V_{GS} = 2.5 \text{ V}, I_D = 1 \text{ A}$		0.062	0.08	
Forward Transconductance ^b	g_{fs}	$V_{DS} = 10 \text{ V}, I_D = 5.0 \text{ A}$		14		S
Diode Forward Voltage ^b	V_{SD}	$I_S = 5.0 \text{ A}, V_{GS} = 0 \text{ V}$		0.81	1.2	V
Dynamic^a						
Total Gate Charge	Q_g	$V_{DS} = 6 \text{ V}, V_{GS} = 4.5 \text{ V}, I_D = 5.0 \text{ A}$		9	20	nC
Gate-Source Charge	Q_{gs}			2		
Gate-Drain Charge	Q_{gd}			2.6		
Turn-On Delay Time	$t_{d(on)}$	$V_{DD} = 6 \text{ V}, R_L = 6 \Omega$ $I_D \cong 1 \text{ A}, V_{GEN} = 4.5 \text{ V}, R_G = 6 \Omega$		14	40	ns
Rise Time	t_r			13	30	
Turn-Off Delay Time	$t_{d(off)}$			35	60	
Fall Time	t_f			9	30	
Source-Drain Reverse Recovery Time	t_{rr}		$I_F = 5.0 \text{ A}, di/dt = 100 \text{ A}/\mu\text{s}$		60	

Notes

- a. Guaranteed by design, not subject to production testing.
- b. Pulse test; pulse width $\leq 300 \mu\text{s}$, duty cycle $\leq 2\%$.



TYPICAL CHARACTERISTICS (25°C UNLESS NOTED)

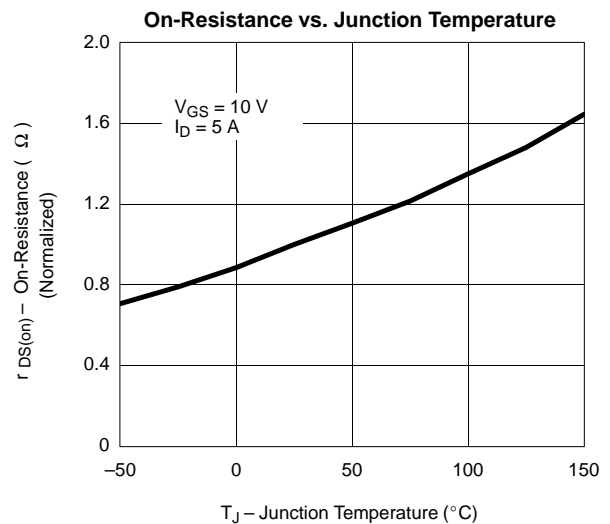
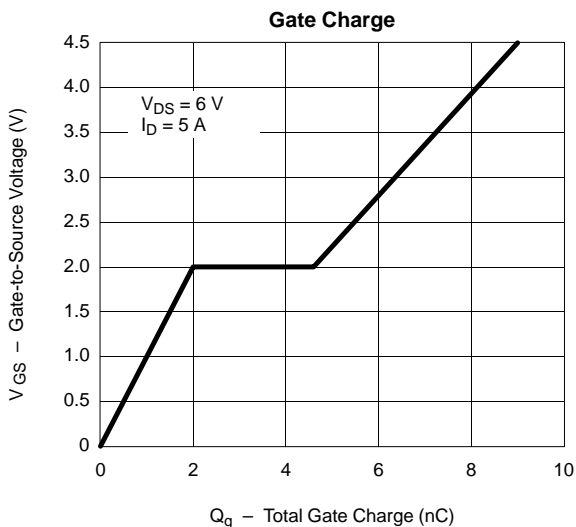
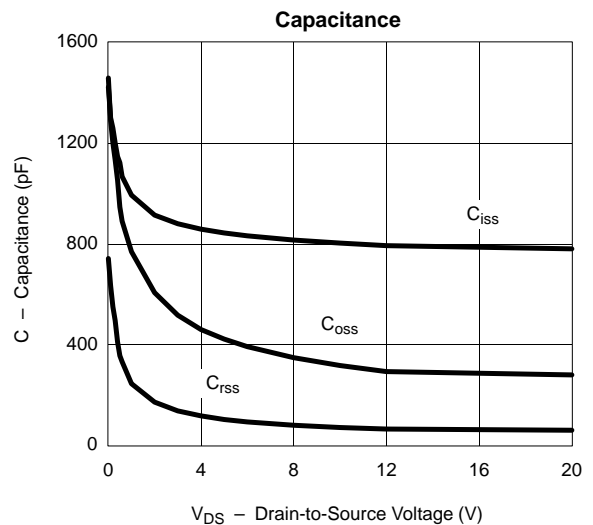
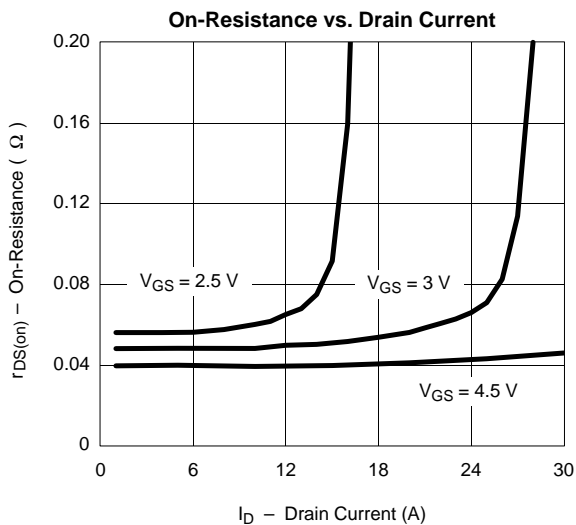
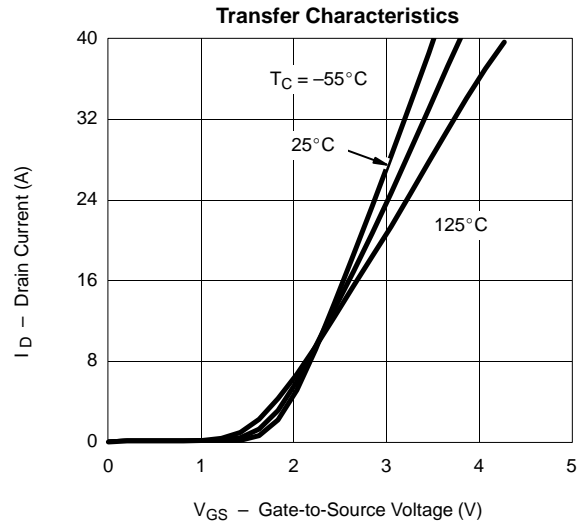
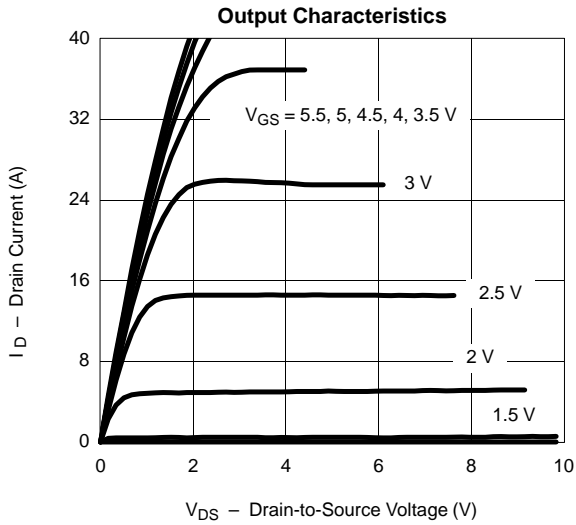

TYPICAL CHARACTERISTICS (25°C UNLESS NOTED)

