

TRIACS

- GLASS PASSIVATED CHIP
- FAST-ON CONNEXIONS
- I_{GT} SPECIFIED IN FOUR QUADRANTS
- INSULATING VOLTAGE 2500 V_{RMS}
- UL RECOGNIZED (E81734)

DESCRIPTION

This new design of plastic insulated power triacs offers maximum efficiency with maximum ease of mounting.

ADVANTAGES

- NO TAPPING REQUIRED FOR FIXING
- EXCELLENT THERMAL IMPEDANCE AND HIGH RELIABILITY CONSTRUCTION

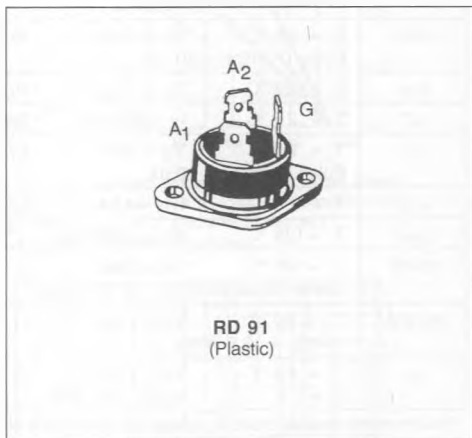
ABSOLUTE RATINGS (limiting values)

Symbol	Parameter	Value	Unit
$I_{T(RMS)}$	RMS on-state Current (360° conduction angle)	$T_C = 80\text{ °C}$ 30	A
I_{TSM}	Non Repetitive Surge Peak on-state Current (T_j initial = 25 °C - Half sine wave)	$t = 8.3\text{ ms}$	260
		$t = 10\text{ ms}$	250
I^2t	I^2t Value for Fusing	$t = 10\text{ ms}$ 312.5	A^2s
di/dt	Critical Rate of Rise of on-state Current (1)	Repetitive $F = 50\text{ Hz}$	10
		Non Repetitive	50
T_{sig} T_j	Storage and Operating Junction Temperature Range	- 40 to 125 - 40 to 125	°C °C

Symbol	Parameter	BTA 25-					Unit
		200A	400A	600A	700A	800A	
V_{DRM}	Repetitive Peak off-state Voltage (2)	200	400	600	700	800	V

- (1) $I_G = 1.5\text{ A}$ $di_G/dt = 1\text{ A}/\mu s$
 (2) $T_j = 125\text{ °C}$.

THERMAL RESISTANCES

Symbol	Parameter	Value	Unit
$R_{th(c-h)}$	Contact (case-heatsink) with Grease	0.15	°C/W
$R_{th(j-c)}\text{ DC}$	Junction to Case for DC	1.47	°C/W
$R_{th(j-c)}\text{ AC}$	Junction to Case for 360 ° Conduction Angle ($F = 50\text{ Hz}$)	1.1	°C/W

GATE CHARACTERISTICS (maximum values)

$P_{GM} = 40 \text{ W}$ ($t_p = 10 \mu\text{s}$)

$P_{G(AV)} = 1 \text{ W}$

$I_{GM} = 6 \text{ A}$ ($t_p = 10 \mu\text{s}$)

$V_{GM} = 16 \text{ V}$ ($t_p = 10 \mu\text{s}$)

ELECTRICAL CHARACTERISTICS

Symbol	Test Conditions			Quadrants	Min.	Typ.	Max.	Unit
I_{GT}	$T_j = 25 \text{ }^\circ\text{C}$ Pulse Duration $> 20 \mu\text{s}$	$V_D = 12 \text{ V}$	$R_L = 33 \text{ } \Omega$	I-II-III	1		100	mA
				IV	1		150	
V_{GT}	$T_j = 25 \text{ }^\circ\text{C}$ Pulse Duration $> 20 \mu\text{s}$	$V_D = 12 \text{ V}$	$R_L = 33 \text{ } \Omega$	I-II-III-IV			1.5	V
V_{GD}	$T_j = 125 \text{ }^\circ\text{C}$	$V_D = V_{DRM}$	$R_L = 3.3 \text{ k}\Omega$	I-II-III-IV	0.2			V
I_H^*	$T_j = 25 \text{ }^\circ\text{C}$	$I_T = 500 \text{ mA}$	Gate Open			30	100	mA
I_L	$T_j = 25 \text{ }^\circ\text{C}$ Pulse Duration $> 20 \mu\text{s}$	$V_D = 12 \text{ V}$	$I_G = 300 \text{ mA}$	I-II-III-IV			150	mA
V_{TM}^*	$T_j = 25 \text{ }^\circ\text{C}$	$I_{TM} = 42 \text{ A}$	$t_p = 10 \text{ ms}$				1.8	V
I_{DRM}^*	$T_j = 125 \text{ }^\circ\text{C}$	V_{DRM} Specified				1.5	6	mA
dv/dt^*	$T_j = 125 \text{ }^\circ\text{C}$	Gate Open Linear Slope up to $V_D = 67\% V_{DRM}$			250			V/ μs
$(dv/dt)_c^*$	$T_C = 80 \text{ }^\circ\text{C}$ $(di/dt)_c = 13.3 \text{ A/ms}$	$V_D = V_{DRM}$	$I_T = 42 \text{ A}$		10			V/ μs
t_{gt}	$T_j = 25 \text{ }^\circ\text{C}$	$V_D = V_{DRM}$	$I_T = 42 \text{ A}$ $di_G/dt = 10 \text{ A}/\mu\text{s}$	I-II-III-IV		2.5		μs

* For either polarity of electrode A_2 voltage with reference to electrode A_1 .

PACKAGE MECHANICAL DATA : RD 91 Plastic

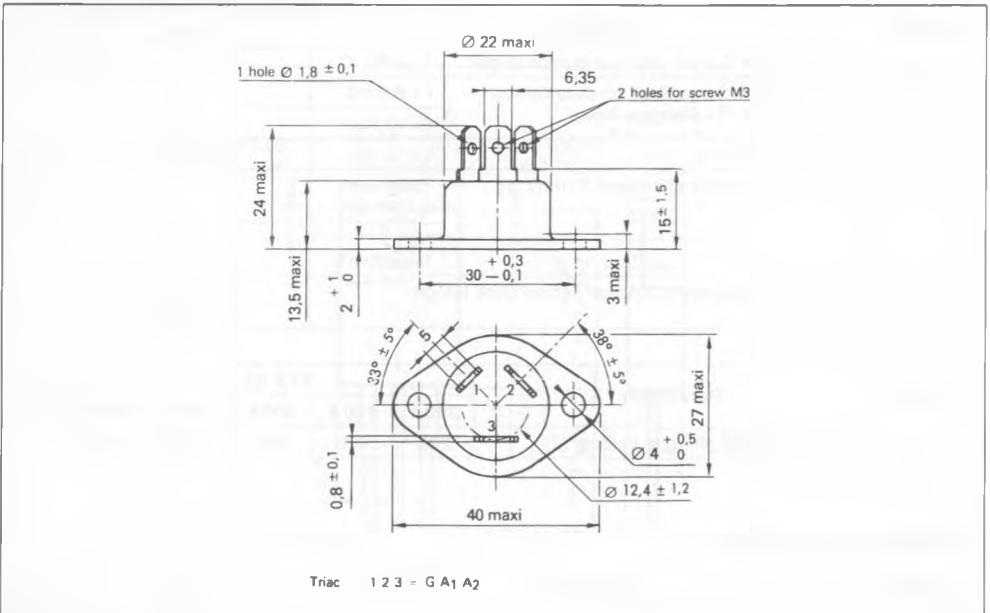

Cooling method : by conduction (method C)

Marking : type number

Weight : 15 g

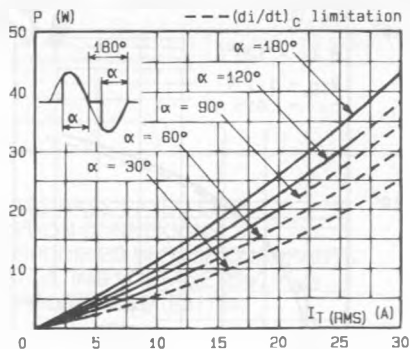

Fig. 1 - Maximum mean power dissipation versus RMS on-state current ($f = 60$ Hz).

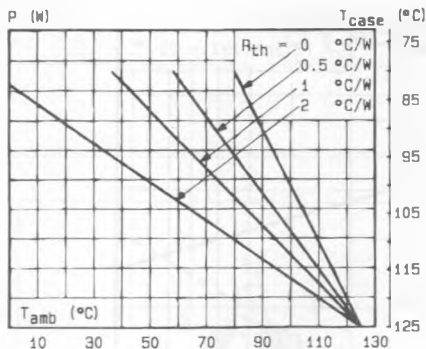

Fig. 2 Correlation between maximum mean power dissipation and maximum allowable temperatures (T_{amb} and T_{case}) for different thermal resistances heatsink + contact.

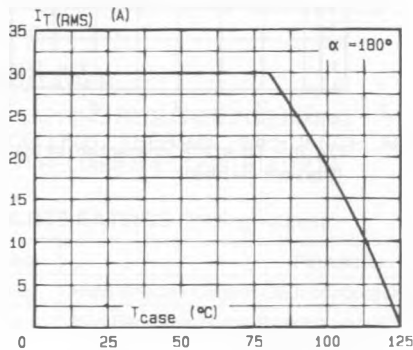

Fig. 3 - RMS on-state current versus case temperature.

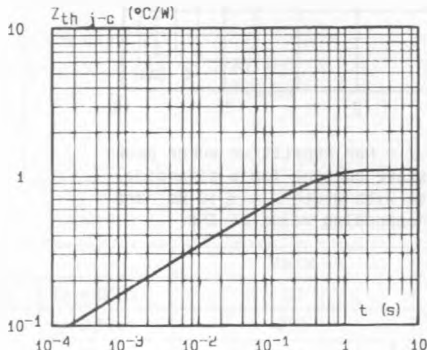

Fig. 4 Thermal transient impedance junction to case versus pulse duration.

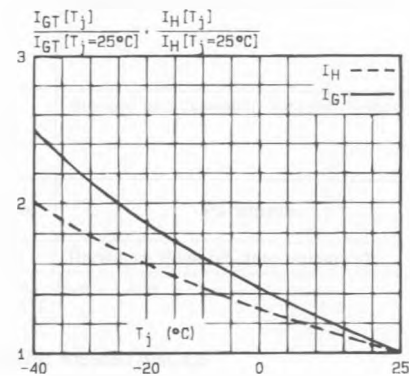

Fig. 5 - Relative variation of gate trigger current and holding current versus junction temperature.

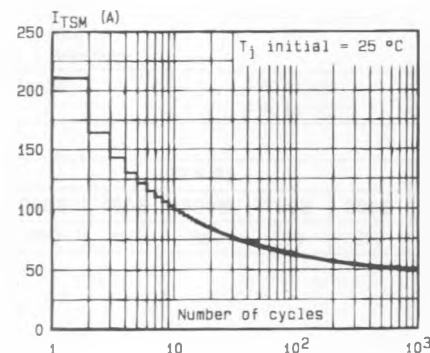

Fig. 6 - Non repetitive surge peak on-state current versus number of cycles.

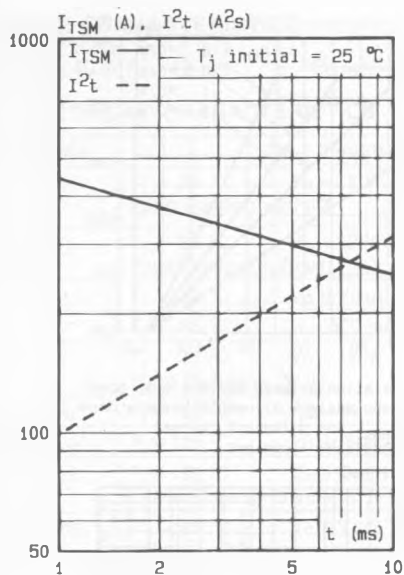

Fig.7 - Non repetitive surge peak on-state current for a sinusoidal pulse with width : $t \leq 10$ ms. and corresponding value of I^2t .

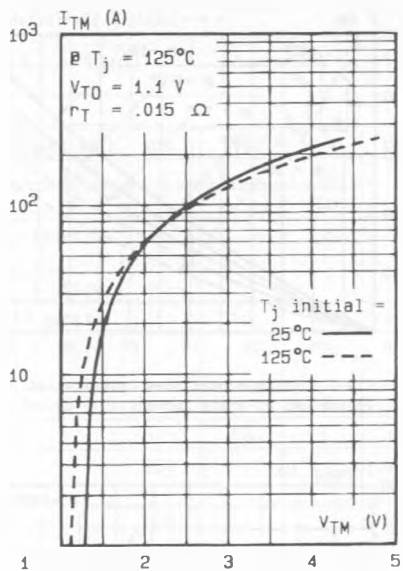

Fig.8 - On-state characteristics (maximum values).