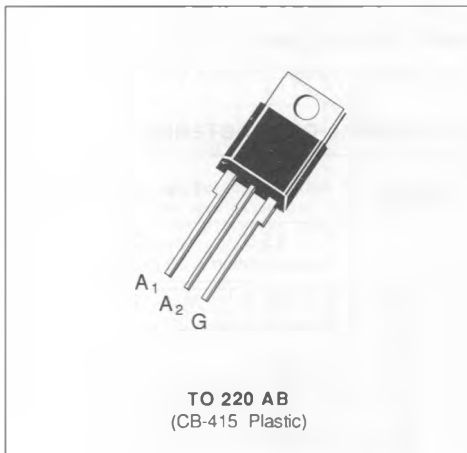

**SNUBBERLESS TRIACS**

- $I_{TRMS} = 6\text{ A}$  at  $T_c = 100\text{ }^\circ\text{C}$ .
- $V_{DRM} : 200\text{ V}$  to  $800\text{ V}$ .
- $I_{GT} = 35\text{ mA}$  (QI-II-III).
- GLASS PASSIVATED CHIP.
- HIGH SURGE CURRENT :  $I_{TSM} = 60\text{ A}$ .
- HIGH COMMUTATION CAPABILITY :  
 $(di/dt)_c > 3.5\text{ A/ms}$  without snubber.

**DESCRIPTION**

New range suited for applications such as phase control and static switching on inductive or resistive load.

**ABSOLUTE RATINGS** (limiting values)

Symbol	Parameter		Value	Unit
$I_{TRMS}$	RMS on-state current (360 ° conduction angle)	$T_c = 100\text{ }^\circ\text{C}$	6	A
$I_{TSM}$	Non repetitive surge peak on-state current ( $T_j$ initial = $25\text{ }^\circ\text{C}$ )	$t = 8.3\text{ ms}$	63	A
		$t = 10\text{ ms}$	60	
$I^2 t$	$I^2 t$ value	$t = 10\text{ ms}$	18	$\text{A}^2\text{ s}$
$di/dt$	Critical rate of rise of on-state current (1)	Repetitive $F = 50\text{ Hz}$	20	A / $\mu\text{s}$
		Non Repetitive	100	
$T_{stg}$ $T_j$	Storage and operating junction temperature range		- 40, + 150 - 40, + 125	$^\circ\text{C}$ $^\circ\text{C}$

Symbol	Parameter	BTB 06-					Unit
		200 CW	400 CW	600 CW	700 CW	800 CW	
$V_{DRM}$	Repetitive peak off-state voltage (2)	$\pm 200$	$\pm 400$	$\pm 600$	$\pm 700$	$\pm 800$	V

(1) Gate supply :  $I_G = 350\text{ mA}$  –  $di_G / dt = 1\text{ A} / \mu\text{s}$ .

(2)  $T_j = 125\text{ }^\circ\text{C}$ .

**THERMAL RESISTANCES**

Symbol	Parameter	Value	Unit
$R_{th(j-a)}$	Junction to ambient	60	°C/W
$R_{th(j-c)}$ DC	Junction to case for DC	3.5	°C/W
$R_{th(j-c)}$ AC	Junction to case for 360 ° conduction angle (F = 50 Hz)	2.7	°C/W

**GATE CHARACTERISTICS** (maximum values)

$P_{GM} = 40 \text{ W}$  ( $t = 10 \mu\text{s}$ )    $P_{G(AV)} = 1 \text{ W}$     $I_{GM} = 4 \text{ A}$  ( $t = 10 \mu\text{s}$ )    $V_{GM} = 16 \text{ V}$  ( $t = 10 \mu\text{s}$ ).

**ELECTRICAL CHARACTERISTICS**

Symbol	Test Conditions	Quadrants	Min.	Typ.	Max.	Unit
$I_{GT}$	$T_j = 25 \text{ °C}$ $V_D = 12 \text{ V}$ $R_L = 33 \Omega$ Pulse duration > 20 $\mu\text{s}$	I-II-III	1		35	mA
$V_{GT}$	$T_j = 25 \text{ °C}$ $V_D = 12 \text{ V}$ $R_L = 33 \Omega$ Pulse duration > 20 $\mu\text{s}$	I-II-III			1.5	V
$V_{GD}$	$T_j = 125 \text{ °C}$ $V_D = V_{DRM}$ $R_L = 3.3 \text{ k}\Omega$ Pulse duration > 20 $\mu\text{s}$	I-II-III	0.2			V
$I_H^*$	$T_j = 25 \text{ °C}$ $I_T = 100 \text{ mA}$ $R_L = 140 \Omega$ Gate open				35	mA
$I_L$	$T_j = 25 \text{ °C}$ $V_D = 12 \text{ V}$ $I_G = 350 \text{ mA}$ Pulse duration > 20 $\mu\text{s}$	I-III			50	mA
		II			80	
$V_{TM}^*$	$T_j = 25 \text{ °C}$ $I_{TM} = 8.5 \text{ A}$ $t_p = 10 \text{ ms}$				1.75	V
$I_{DRM}^*$	$T_j = 25 \text{ °C}$ $V_{DRM}$ rated $T_j = 125 \text{ °C}$ $V_{DRM}$ rated	Gate open			0.01	mA
					2	
$dv/dt^*$	$T_j = 125 \text{ °C}$ $V_{DRM}$ rated Gate open Linear slope up to 0.67 $V_{DRM}$		250	500		V/ $\mu\text{s}$
$(di/dt)_c^*$	$T_j = 125 \text{ °C}$ $V_{DRM}$ rated Without snubber		3.5	7		A/ms
$t_{gl}$	$T_j = 25 \text{ °C}$ $I_T = 8.5 \text{ A}$ $dI_G/dt = 1 \text{ A}/\mu\text{s}$ $V_D = V_{DRM}$	I-II-III		2		$\mu\text{s}$

\* For either polarity of electrode A<sub>2</sub> voltage with reference to electrode A<sub>1</sub>.

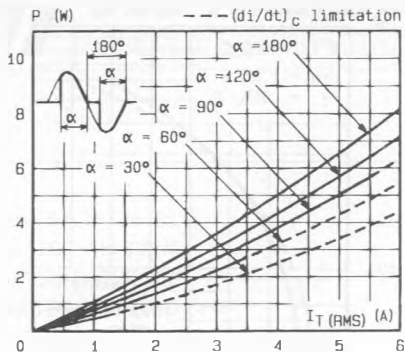

Fig. 1 - Maximum mean power dissipation versus RMS on-state current ( $F = 60$  Hz).

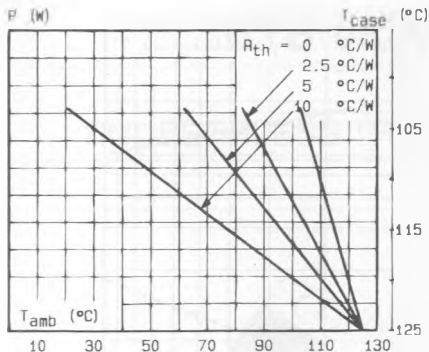

Fig. 2 - Correlation between maximum mean power dissipation and maximum allowable temperatures ( $T_{amb}$  and  $T_{case}$ ) for different thermal resistances (resistances heatsink + contact).

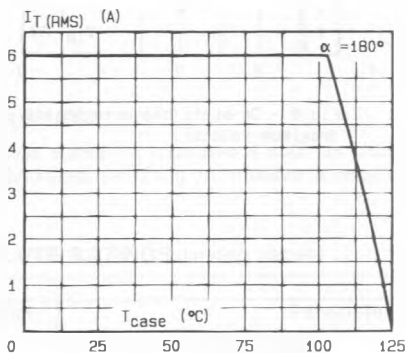

Fig. 3 - RMS on-state current versus case temperature.

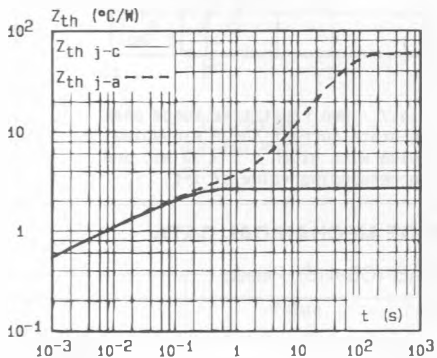

Fig. 4 - Thermal transient impedance junction to case and junction to ambient versus pulse duration.

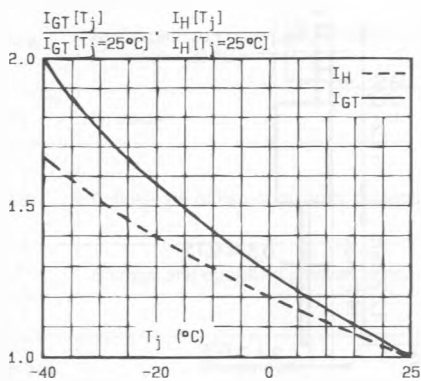

Fig. 5 - Relative variation of gate trigger current and holding current versus junction temperature.

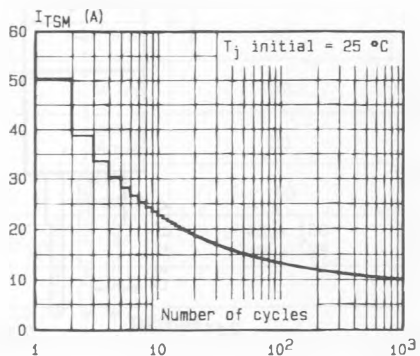

Fig. 6 - Non repetitive surge peak on-state current versus number of cycles.

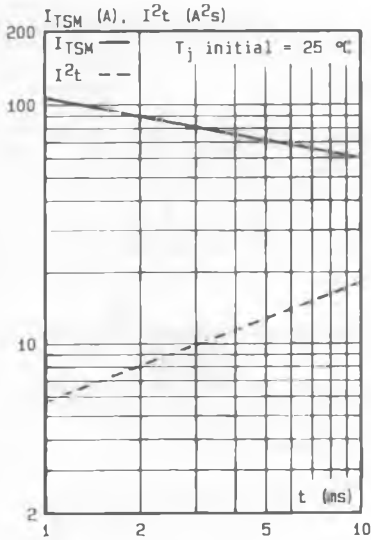

Fig.7 - Non repetitive surge peak on-state current for a sinusoidal pulse with width :  $t \leq 10$  ms. and corresponding value of  $I^2t$ .

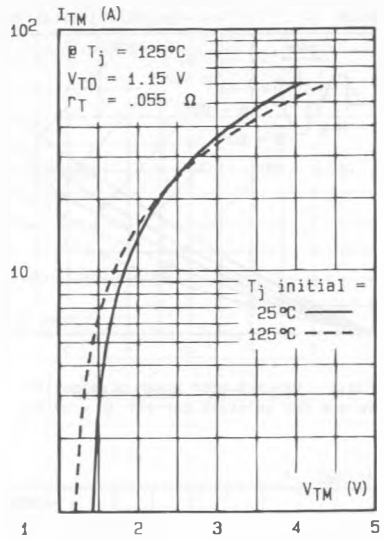
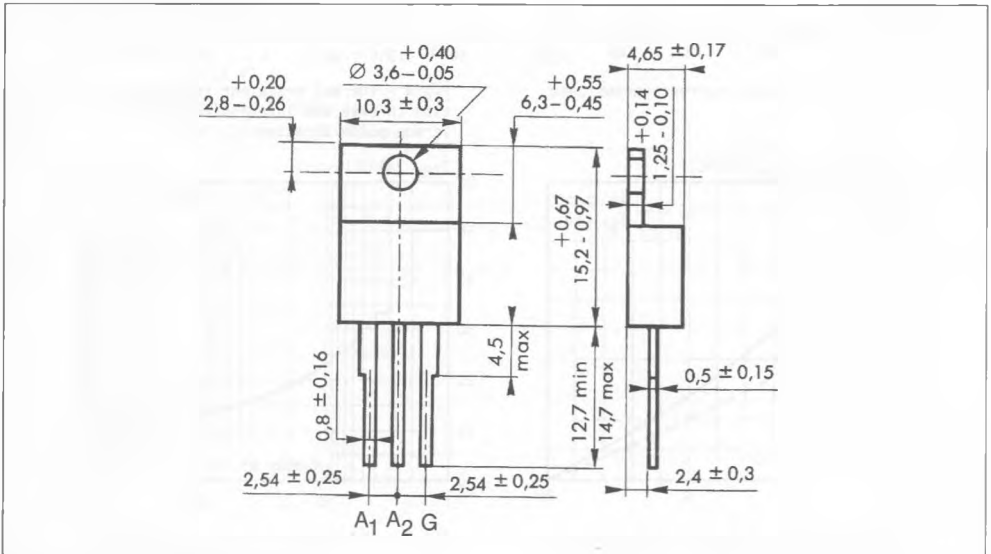

Fig.8 - On-state characteristics (maximum values).

PACKAGE MECHANICAL DATA

TO 220 AB (CB-415) Plastic



Cooling method : by conduction (method C)  
 Marking : type number  
 Weight : 2 g